

ASSEMBLY INSTRUCTIONS

Kit Contents :-

1.Allen Bolt-7Pc.
8/32

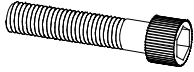

2.Washer-7Pc.
8mm.

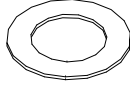

3.Allenkey-1Pc.
7/32



4.Bolt-4Pc.
20x8mm.

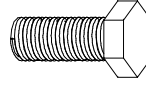

5.Washer-4Pc.
8mm.



6.Spanner-1Pc.
12-13no.

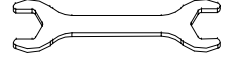

Steps:-

1. Keep the adjusting base on a protective surface.
2. Using Allen Key & Allen bolt fix the two legs to the adjusting base by matching "A" & "B" on the two leg to the "A" & "B" on adjusting base(See image 2).
3. Unscrew the handle using Spanner from inner section and fix the same in front(See image 3). Also fix the Wing Bolt making sure that the Wing Bolt is engaged in the looking gears of adjusting base.
4. Now place the table top aligned to the base assembly and fix it using bolts provided(See image 4).
5. Table is ready to use.
6. **Adjustment:** To raise the table height, gently loosen the Wing Bolt making sure Wing Bolt is not engaged in gear holes. Now rotate the crank handle to raise the height of the table top to its desired height. Once the height is achieved tighten the Wing Bolt back .

1.

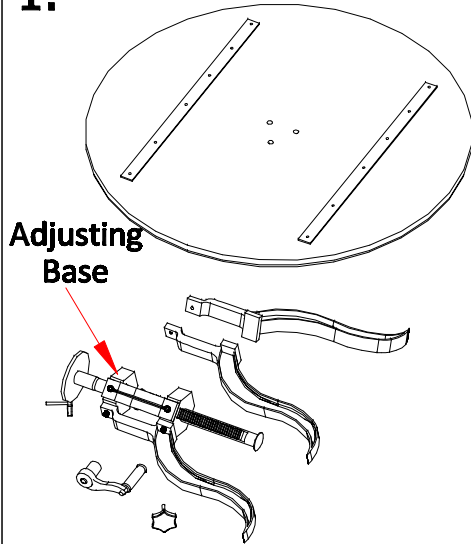

2.

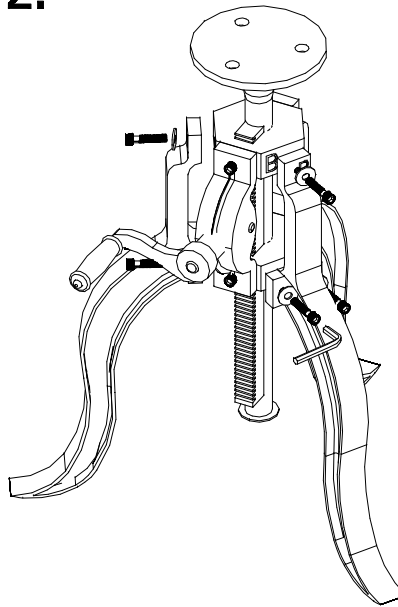

3.

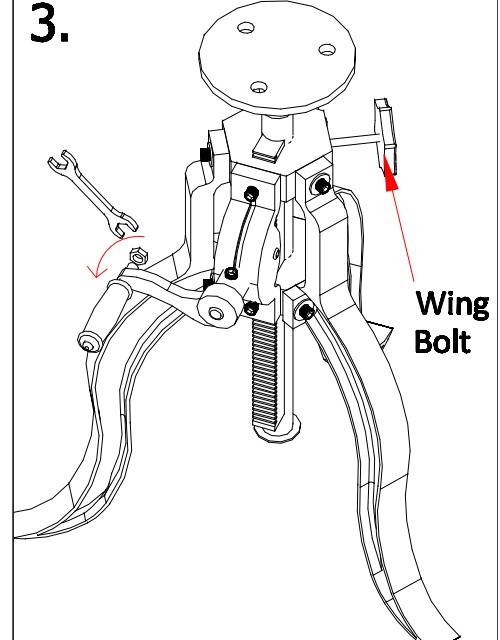

4.

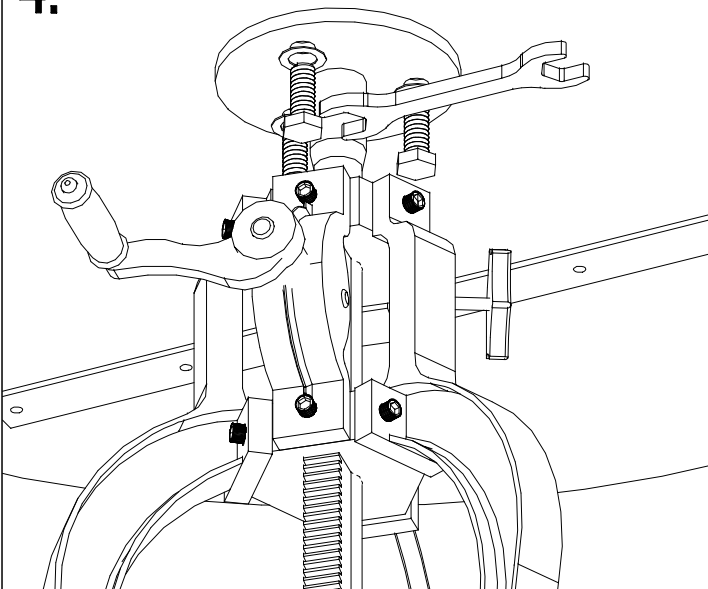

5.

