

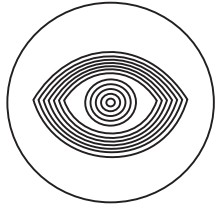

## Part List and Hardware List

PRICE	DESCRIPTION	PICTURE	QUANTITY
A	METAL TOP		X1
B	METAL PIPE		X1
C	METAL BASE		X1

### PREPARATION

Before beginning assembly of product, make sure all parts are present. Compare parts with package contents list and hardware contents list. If any part is missing or damaged, do not attempt to assemble the product. Estimated Assembly Time: 10 minutes

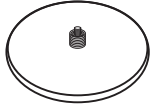
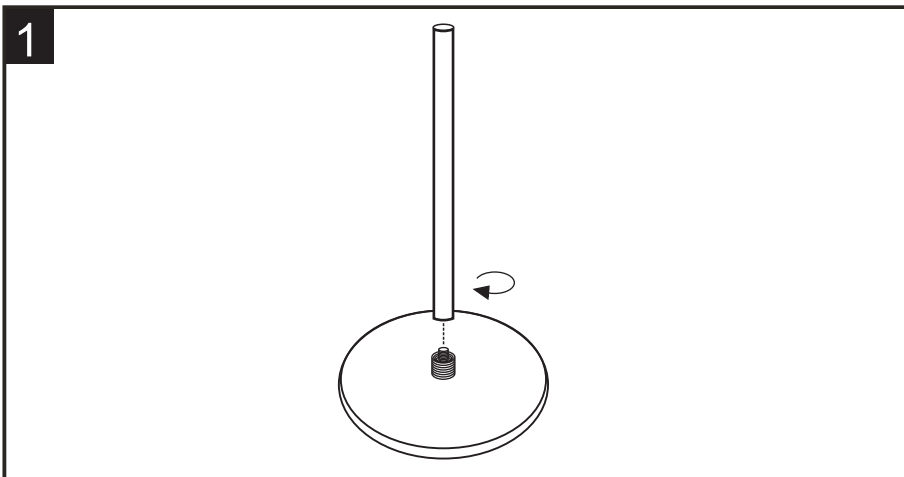

**1**

**Step 1**  
**Place the metal pipe onto the metal base aligning hole to screw and rotate it clock wise until it tighten.**

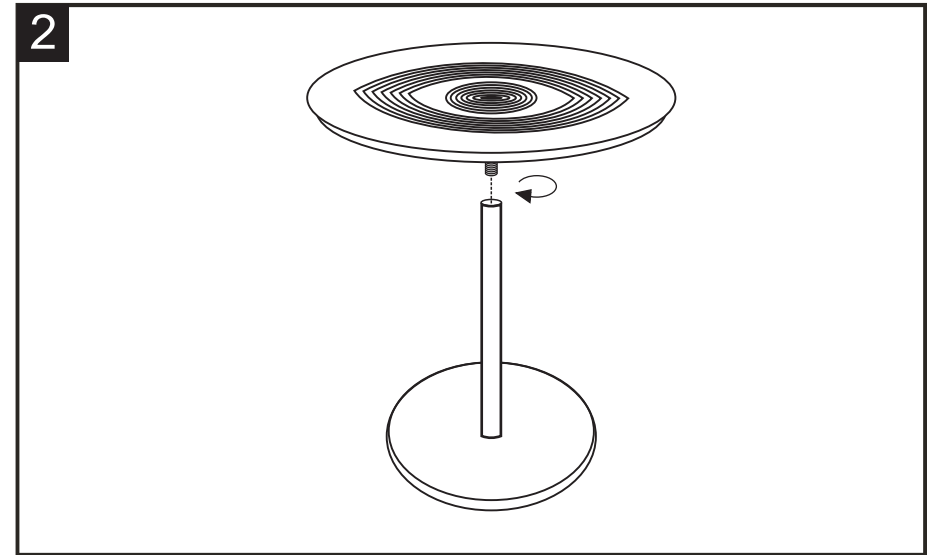

**2**

**Step 2**  
**Put the Metal top onto the metal pipe aligning hole to screw and rotate it clock wise until it tighten.**

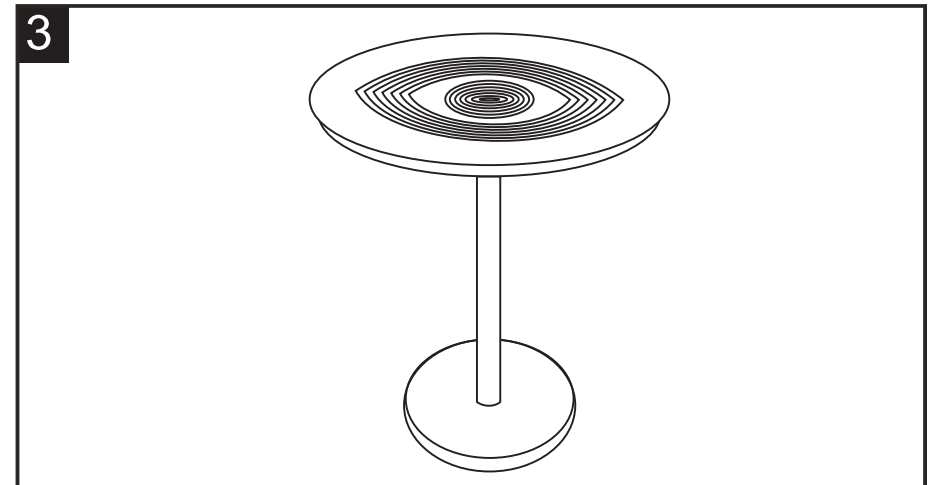

**3**

**Your table is ready to use.**

## CARE AND MAINTENANCE

1. Do not use acids or alkaline cleaning agents.
2. Sharp objects will damage and scratch the surface.
3. Wipe the surface with a soft, damp cloth.
4. Please make sure that you have all parts indicated before you begin assembly of this item
5. This item should be assembled on a soft surface to prevent scratching the finish during assembly
6. This item may require periodic tightening

## EYE HANDPAINTED SIDE TABLE TOV-OC18330

# TOV

## EYE HANDPAINTED SIDE TABLE ASSEMBLY INSTRUCTIONS

