

# ASSEMBLY INSTRUCTIONS

Item PT1837 PT1737

## X Coffee Table

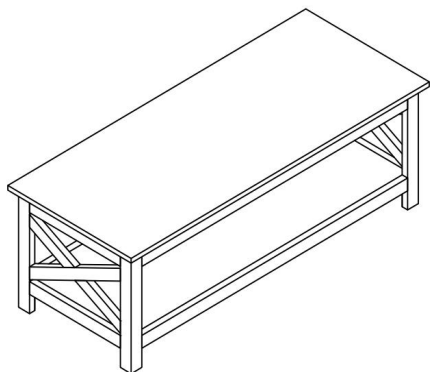

PARTS INVENTORY			
ID	DESCRIPTION	PIC	QTY
<b>A1</b>	TOP		1
<b>A2</b>	FRAME		1
<b>A3</b>	SHELF		1
<b>A4</b>	LEG		2
B	BOLT M6x40mm		18
C	LOCK WASHER		18
D	FACED WASHER		18
E	ALLEN KEY		1
F	FELT PAD		4

### STEP 1

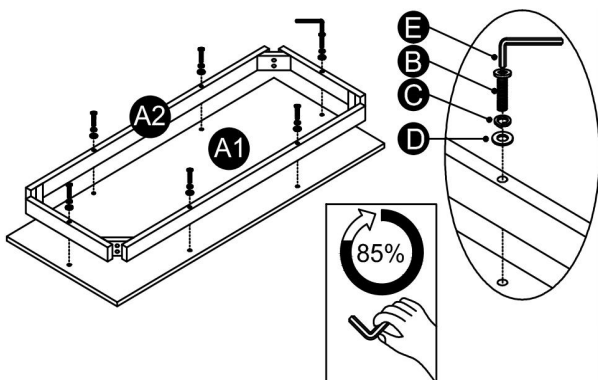

### STEP 2

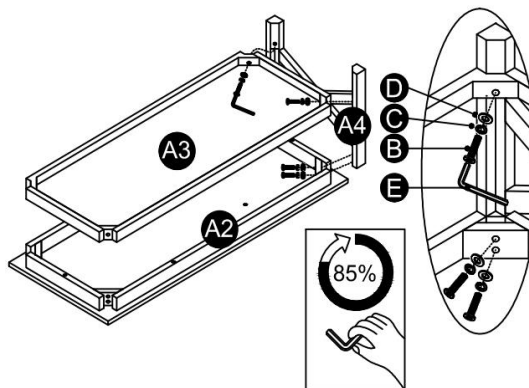

### STEP 3

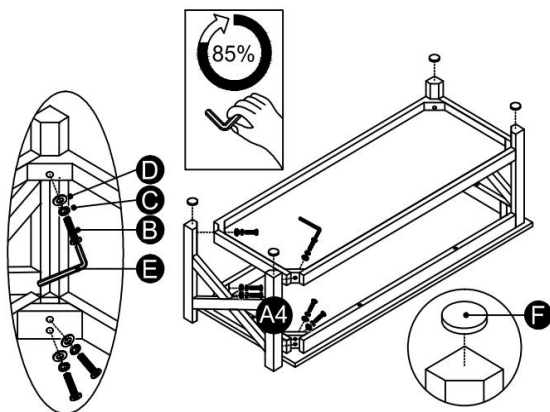

### STEP 4

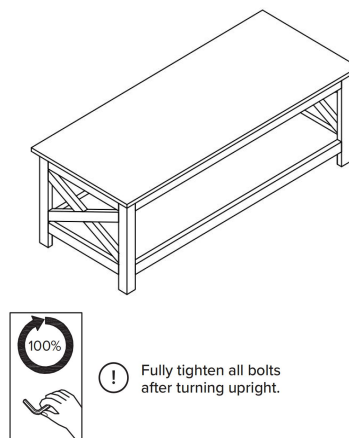

#### Top Tips before you start!

Read these instructions carefully and keep for future reference. Refer to parts inventory for guidance, and ensure you have all pieces before starting.

1. We recommend that, where possible, all items are assembled near to the area in which they will be placed in use to avoid moving the product unnecessarily.
2. When assembling, place all parts on a soft, clean, and flat surface such as a carpet to prevent any damage.
3. For ease and speed of assembly, we recommend that before you commence each step of the assembly, that you identify all the parts required for that step.
4. For larger items, please ensure that you have sufficient space and people to assemble your product safely.
5. During assembly, please take care not to over tighten any fittings, as this may damage the product.
6. When placed the front, please adjust gap and height, then tighten, two people cooperation is more easy to assemble.