



701 E Industrial PK Dr  
Manchester NH 03109  
877-364-8464

••Pls Check to make sure you have all parts  
otherwise contact local retailer or Sunset  
Trading customer service  
at 877-364-8464"

Thank You for purchasing this Quality product. It has  
been engineered for easy assembly yet constructed for  
durability. Please take the time to read and follow the  
instruction while assembling.

## ASSEMBLY INSTRUCTION

Round Drof Leaf Dining & Pub Table

Ø 42" x ( 2-9" Drop Leaf ) x 30" & 36" H

Model : DLU-TPD-4242-B (TSD-0915)

Model : DLU-TPD-4242-CB (PTSD-0915)

### Sunset Trading®

a div of Sunset Furniture Intl.LLC

- 1 Turn the under side of the Table Top over and place it on a clean and smooth surface such as rug or carpet to avoid the Table Top from being scratched .

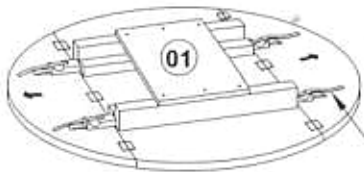

Remove strip before starting assembly

- 4 Fix the Pedestal with Flat Washer, Spring Washer & Hex Nut using the Spanner to tighten it.

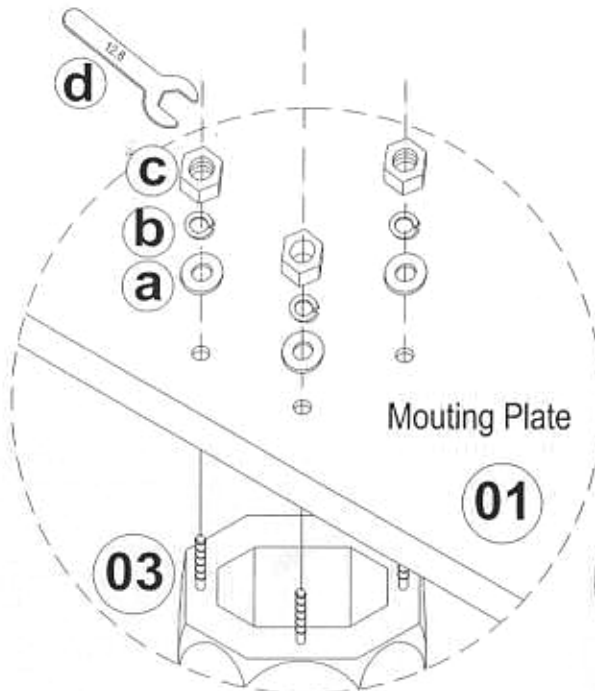

Mounting Plate

- 2 Fix the Footing to the Pedestal with the Flat Washer, Spring Washer And Hex Nut using the Spanner to tighten it.

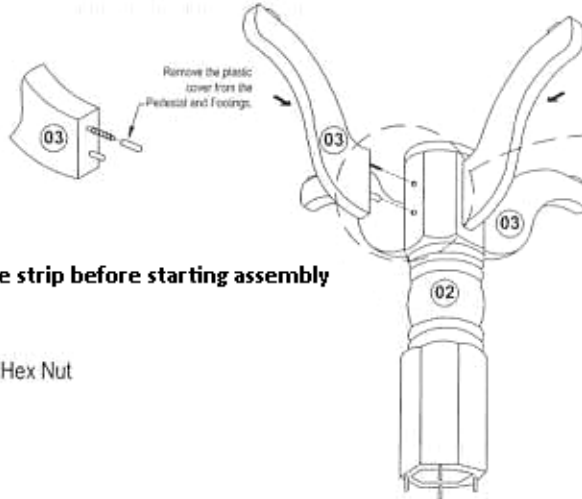

- 3 Repeat the same step for the other three Footing .

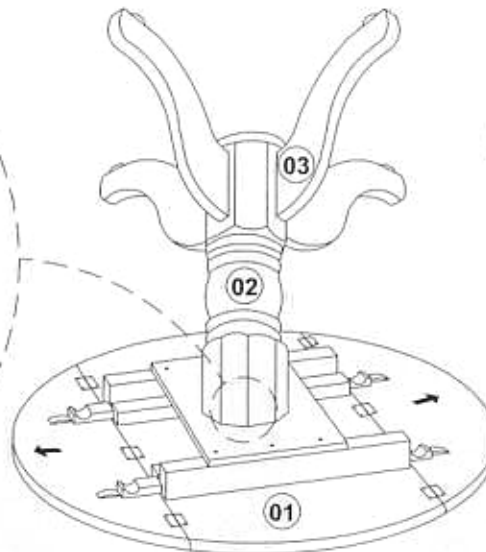
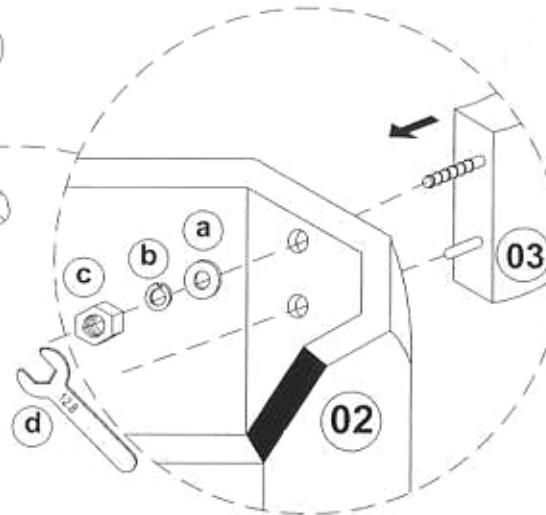

Assembly Completed !!

### List of Part For 1 Set

01		Table Top	1
02		Pedestal	1
03		Table Leg With Leveler	4

### List of hardware For 1 Set

a		Flat Washer 3/8" x 22mm	8
b		Spring Washer 3/8"	8
c		Hexagon Nut 3/8" x 7mm	8
d		Spanner 12.8mm	1

### ⚠ Important Notes

- Keep all hardware parts out of reach of children.
- Must tighten screws periodically. With use screws will become loose. Check tightness of all screws every 6-8 weeks.
- Don't attempt to repair or modify parts that are broken or defective. Please contact the store immediately.
- Do not tighten all screw / bolt until all completely assembled

MADE IN MALAYSIA

## Before you begin:

- Check to be sure that you have all parts and hardware
- Place all wooden pieces on a clean and smooth surface like a carpet to avoid parts being scratched
- Do not tighten all screws/ bolts until completely assembled
- If missing parts or have questions, please email [info@sunsettrading.com](mailto:info@sunsettrading.com) anytime or call Sunset Trading 877-364-8464, M-F 8am-4pm EST.





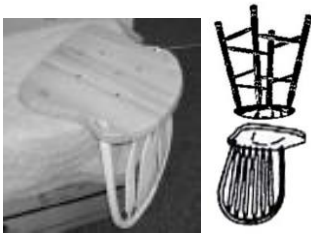





**Step 1.** Place swivel on base with 'TOP FRONT' markings on swivel facing upward. Attach swivel to base using four (4) #10 Philips screws and four (4) flat washers. Tighten with a #10 Philips screwdriver (Not Provided).



**Step 2.** Place seat upside down on table or bench (lay a towel down to protect from scratches) or on the edge of mattress

**\*IMPORTANT:** Make note of marking on top of swivel that reads 'TOP FRONT'. This side of the swivel must be mounted toward the front of the barstool seat in order to provide proper angle for sitting.

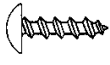
Flip base upside down and place on top of Seat Unit bottom. Line up the four (4) slots in the swivel top

Parts		QTY
Top Seat Unit (Pre-Assembled)		1
Base (Pre-Assembled)		1
Swivel Plate		1
Seat Machine Bolts		4
Lock Washers		4
Flat Washers		8
#10 Philips Screws		4
4mm Allen Wrench		1

with the four (4) nut inserts that are mounted in the seat.

**Step 3.** Put one (1) Lock Washer and one (1) Flat Washer on each Seat Machine Bolt. Attach the swivel to the seat bottom through the access hole in the bottom of the base Unit with all four (4) bolts.

**Step 4.** Screw all 4 bolts in half way with Allen wrench provided. Turning base unit as needed to access the nuts that are inserted on the barstool seat. Tighten all bolts fully when done. Assembly is complete!

