



701 E Industrial PK Dr
Manchester NH 03109
877-364-8464
www.sunsettrading.com
info@sunsettrading.com

** Pls Check to make sure you have all parts otherwise contact local retailer or Sunset Trading customer service at 877-364-8464"

Thank You for purchasing this Quality product. It has been engineered for easy assembly yet constructed for durability. Please take the time to read and follow the instruction while assembling.

ASSEMBLY INSTRUCTION

MODEL NO: DLU-CA113-T/B (DAVE-1819-T/B)
CHINA ASH VANNER TABLE

Sunset Trading®
a div of Sunset Furniture Intl.LLC

Step 1

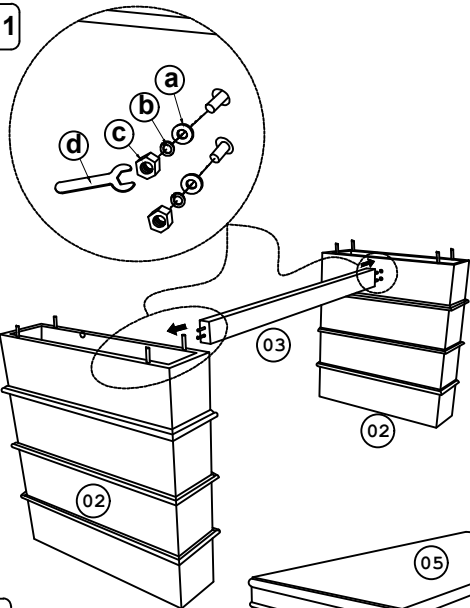

Step 2

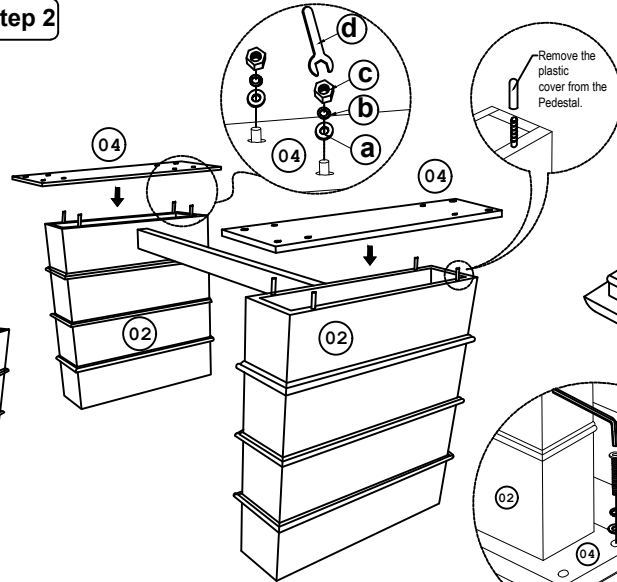

Step 3

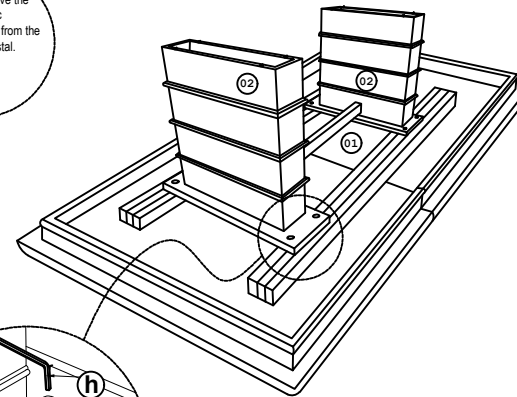

Step 4

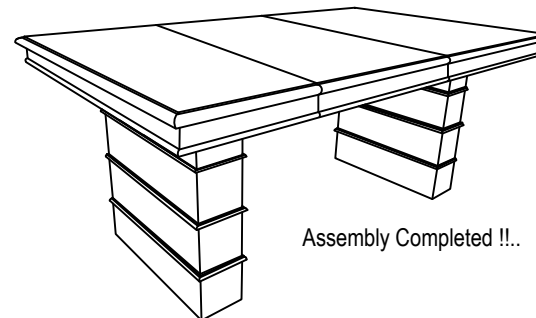
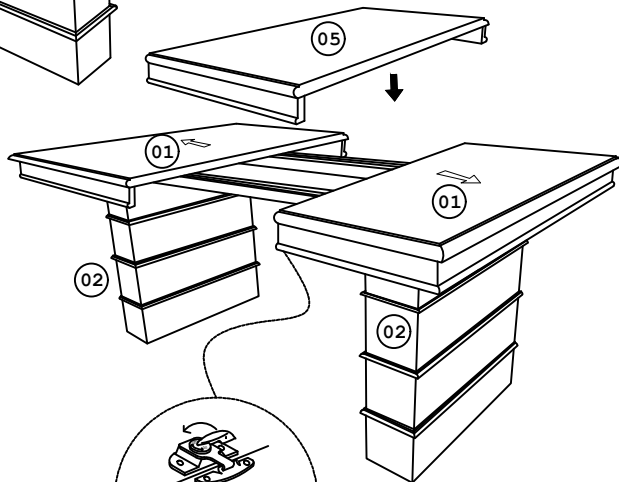

Assembly Completed !!..

Care And Maintenance

- * The Touch of a soft cloth is all the maintenance your wood pieces will ever need.
- * Never use harsh chemicals or abrasive cleaner as they could mark or destroy finish.

Notes

- * Place all wooden parts on a clean and smooth surface such as a rug or carpet to avoid the parts from being scratched.
- * Check to be sure that you have all parts and hardware.
- * Remove all wrapping materials including staples & packing straps before you start to assemble.

List of Part For 1 Set

Code	Figure	Parts	Qty.
01		Table Top	1
02		Pedestal legs	2
03		Center Rail	1
04		Mounting plates	2
05		Center Leaf	1

List of hardware For 1 Set

Code	Figure	Hardware	Qty.
a		Flat Washer 5/16" x 22mm	12
b		Spring Washer 5/16"	12
c		Hexagon Nut 5/16" x 7mm	12
d		Spanner 12.8mm	1
e		Flat Washer 1/4" x 18mm	8
f		Spring Washer 1/4"	8
g		JCBC Bolt M6 x 40mm	8
h		Allen Key M4	1

Important Notes

- * Keep all hardware parts out of reach of children.
- * Must tighten screws periodically. With use screws will become loose. Check tightness of all screws every 6-8 weeks.
- * Don't attempt to repair or modify parts that are broken or defective. Please contact the store immediately.
- * Do not tighten all screw / bolt until all completely assembled

MADE IN MALAYSIA



Unlock the Cam Lock under the table before Side Leaf assembled then lock it.



Sunset Trading®

a div of Sunset Furniture Intl.LLC

701 E Industrial PK Dr
Manchester NH 03109

877-364-8464

www.sunsettrading.com

info@sunsettrading.com

**Pls Check to make sure you have all parts otherwise contact local retailer or Sunset Trading customer service at 877-364-8464"

Thank You for purchasing this Quality product. It has been engineered for easy assembly yet constructed for durability. Please take the time to read and follow the instruction while assembling.

ASSEMBLY INSTRUCTION

Model : DLU-CA-C113(C 1819 RTA)

CHINA ASH SIDE CHAIR

Step 1

Step 2

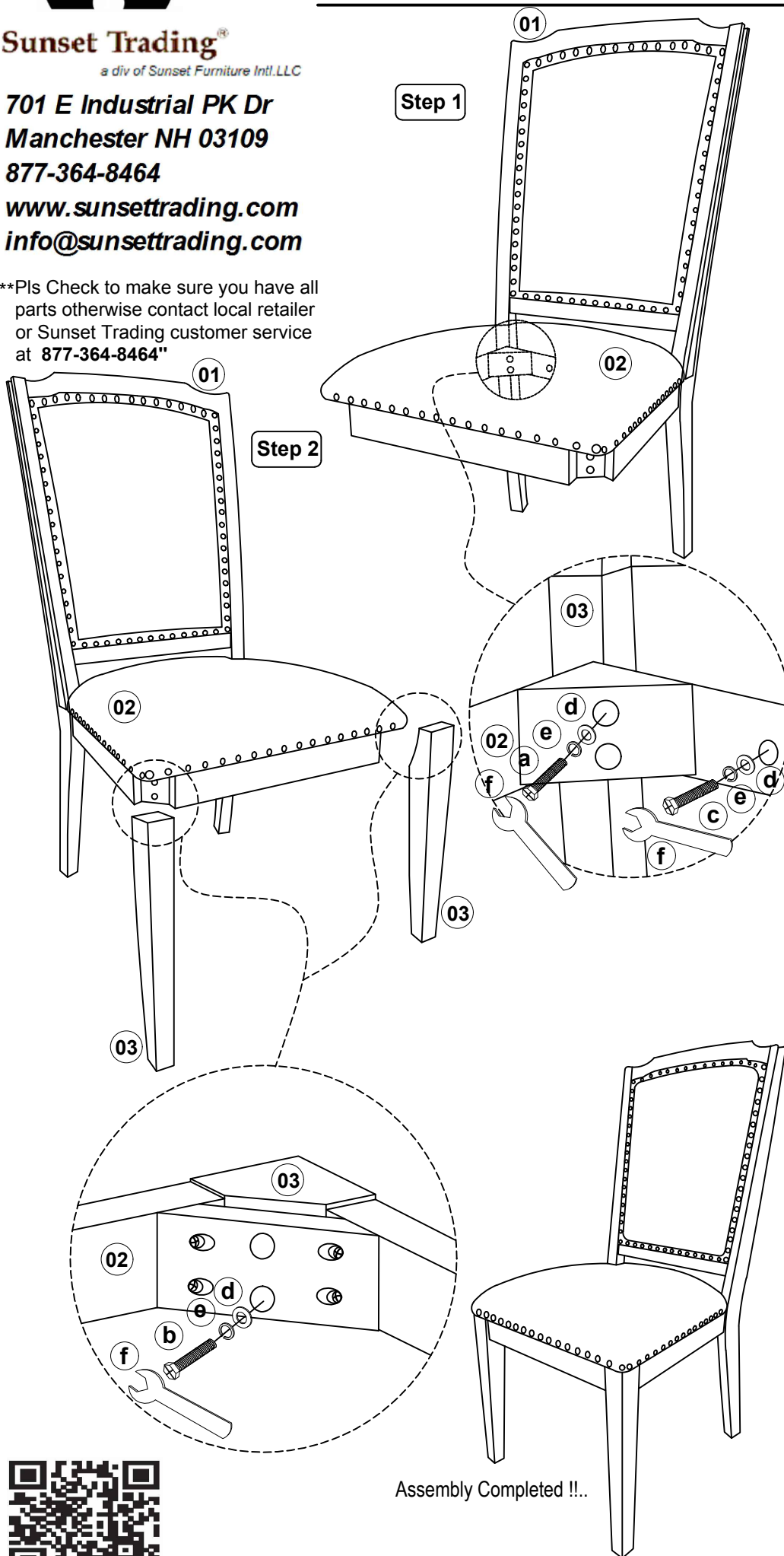

List of Part For 1 Set

Code	Figure	Part	Qty.
01		Back Frame	1
02		Seat	1
03		Front Leg	2

List of hardware For 1 Set

Code	Figure	Hardware	Qty.
a		Hex.Bolt M6 x 80mm	4
b		Hex.Bolt M6 x 60mm	4
c		Hex.Bolt M6 x 40mm	2
d		Flat Washer 1/4" x 18 mm	10
e		Spring Washer 1/4"	10
f		Spanner 10 mm	1



Important Notes

- * Keep all hardware parts out of reach of children.
- * Must tighten screws periodically. With use screws will become loose. Check tightness of all screws every 6-8 weeks.
- * Don't attempt to repair or modify parts that are broken or defective. Please contact the store immediately.
- * Do not tighten all screw / bolt until all completely assembled.

Notes

- * Place all wooden parts on a clean and smooth surface such as a rug or carpet to avoid the parts from being scratched.
- * Check to be sure that you have all parts and hardware.
- * Remove all wrapping materials including staples & packing straps before you start to assemble.
- * Do not tighten all screws / bolts until all completely assembled.

Care And Maintenance

- * The Touch of a soft cloth is all the maintenance your wood pieces will ever need.
- * Never use harsh chemicals or abrasive cleaner as they could mark or destroy finish.

Assembly Completed !!..

