



**Sunset Trading®**

a div of Sunset Furniture Intl.LLC

11 Delta Dr  
Londonderry NH 03053  
877-364-8464

\*\*Pls Check to make sure you will have all parts otherwise contact local retailer or Sunset Trading customer service at 877-364-8464\*\*

**ASSEMBLY INSTRUCTIONS**

KITCHEN ISLAND  
24"W x 60-1/2"L x 35"H

Model : CY-KI-TT-02

Thank you for purchasing this Quality product. It has been engineered for easy assembly yet constructed for durability. Please take the time to read and follow the instructions while assembling.

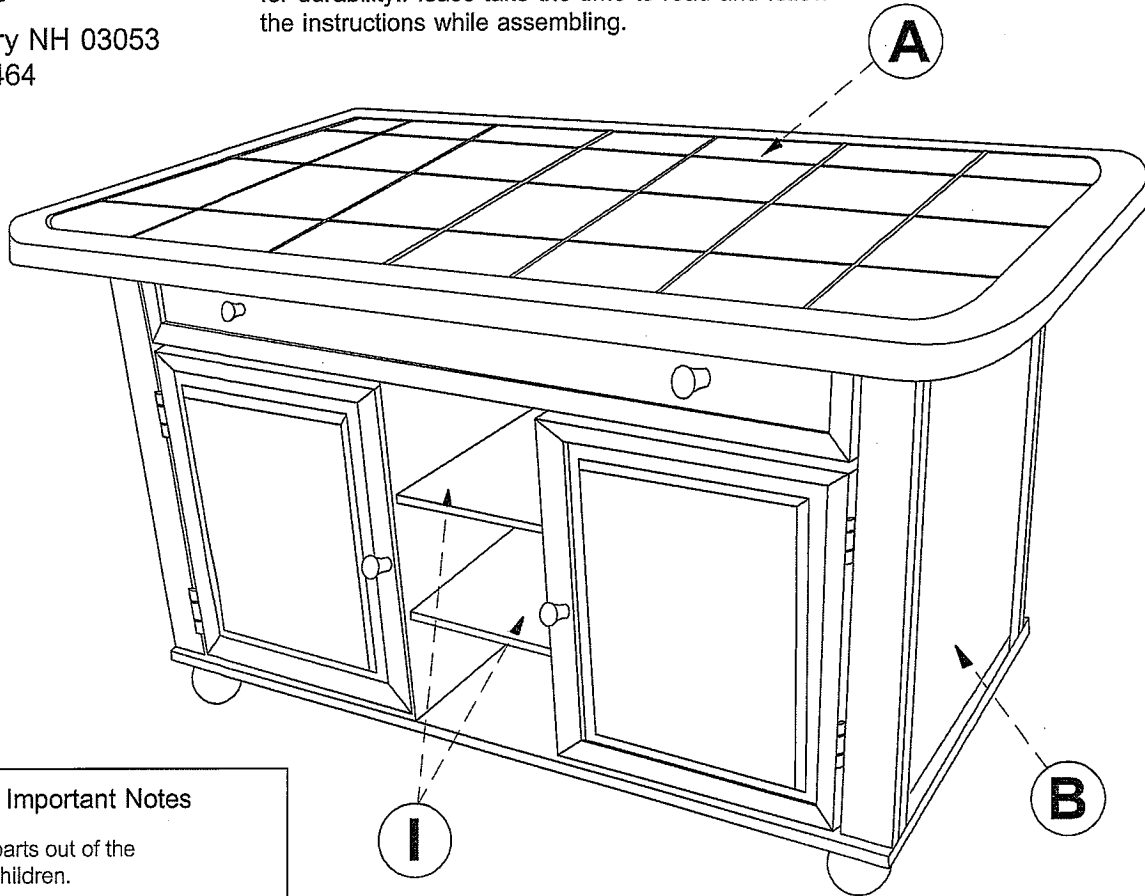

**⚠ Important Notes**

- Keep all parts out of the reach of children.
- Must tighten nuts periodically. with use nuts will become loose. Check tightness of all nuts every 6-8 weeks.
- Do not attempt to repair or modify parts that are broken or defective. Please contact your local retailer immediately.
- Do not tighten all nuts until all completely assembled.

**LIST OF PARTS&HARDWARES**

No.	Description	Qty.
(A)	TOP	1 PC.
(B)	BASE	1 PC.
(C)	WOODEN SLIDE	4 PCS.
(D)	LEGS	4 PCS.
(E)	WOODEN KNOB	4 PCS.
(F)	WOODEN SCREW	16 PCS.
(G)	ADJUSTABLE	8 PCS.
(H)	GLUE	1 PC.
(I)	SHELF	2 PCS.

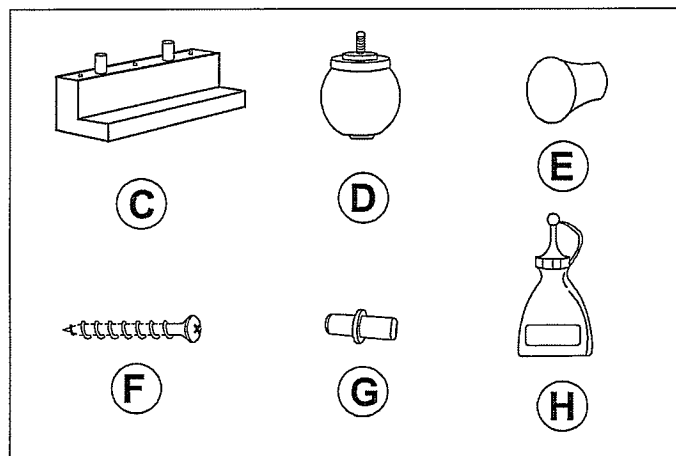



**Sunset Trading®**

a div of Sunset Furniture Intl.LLC

11 Delta Dr  
Londonderry NH 03053  
877-364-8464

\*\*Pls Check to make sure you will have all parts otherwise contact local retailer or Sunset Trading customer service at 877-364-8464\*\*

## ASSEMBLY INSTRUCTIONS

KITCHEN ISLAND

24"W x 60-1/2"L x 35"H

Model : CY-KI-TT-02

Thank you for purchasing this Quality product. It has been engineered for easy assembly yet constructed for durability. Please take the time to read and follow the instructions while assembling.

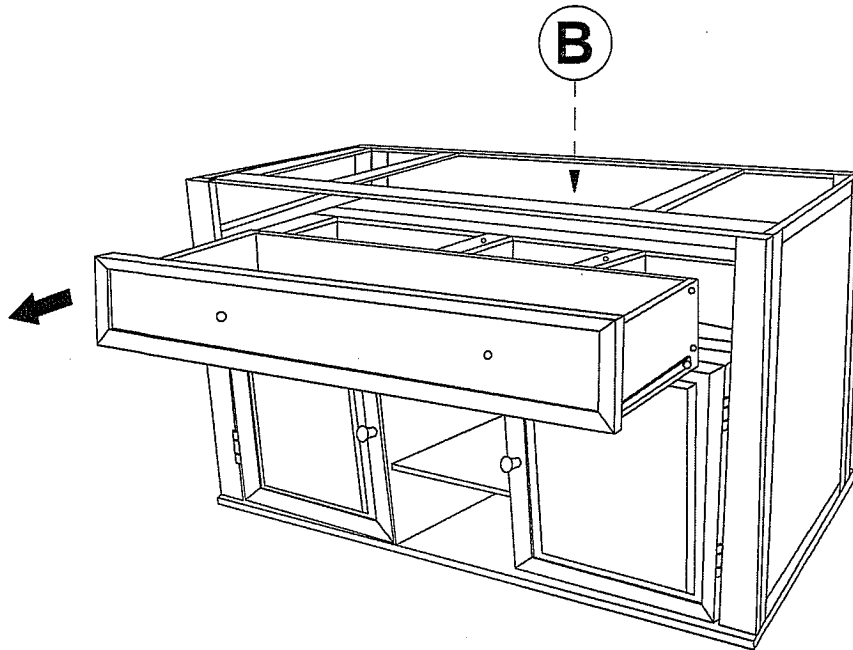

### Step: 1

- OPEN CARTON SO THAT IT CAN BE USED AS WORK SURFACE OF ASSEMBLY.
- REMOVE ALL PARTS FROM CARTON.
- TAKE OFF DRAWER ON EACH DRAWER SLIDE.

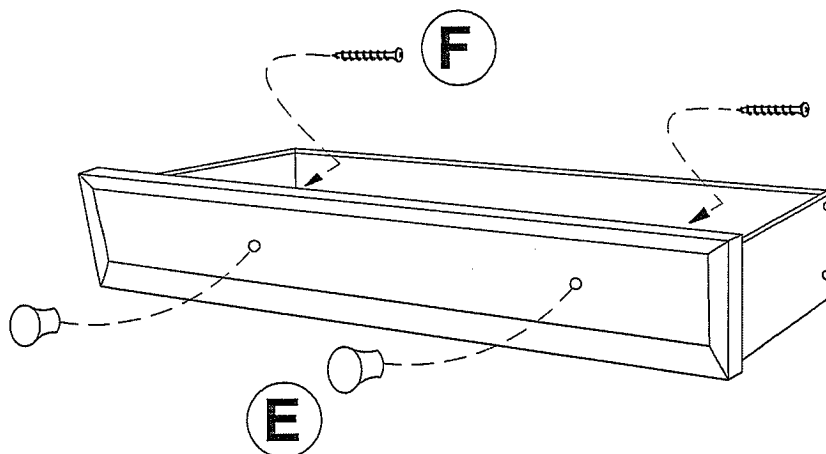

### Step: 2

- ATTACH WOODEN KNOB (E) TO FRONT DOORS BY USING SCREW (F) AND TIGHTENING WITH SCREW DRIVER. (NOT PROVIDED)



**Sunset Trading®**

a div of Sunset Furniture Intl.LLC

11 Delta Dr  
Londonderry NH 03053  
877-364-8464

\*\*Pls Check to make sure you will have all parts otherwise contact local retailer or Sunset Trading customer service at 877-364-8464\*\*

# ASSEMBLY INSTRUCTIONS

KITCHEN ISLAND

24"W x 60-1/2"L x 35"H

Model : CY-KI-TT-02

Thank you for purchasing this Quality product. It has been engineered for easy assembly yet constructed for durability. Please take the time to read and follow the instructions while assembling.

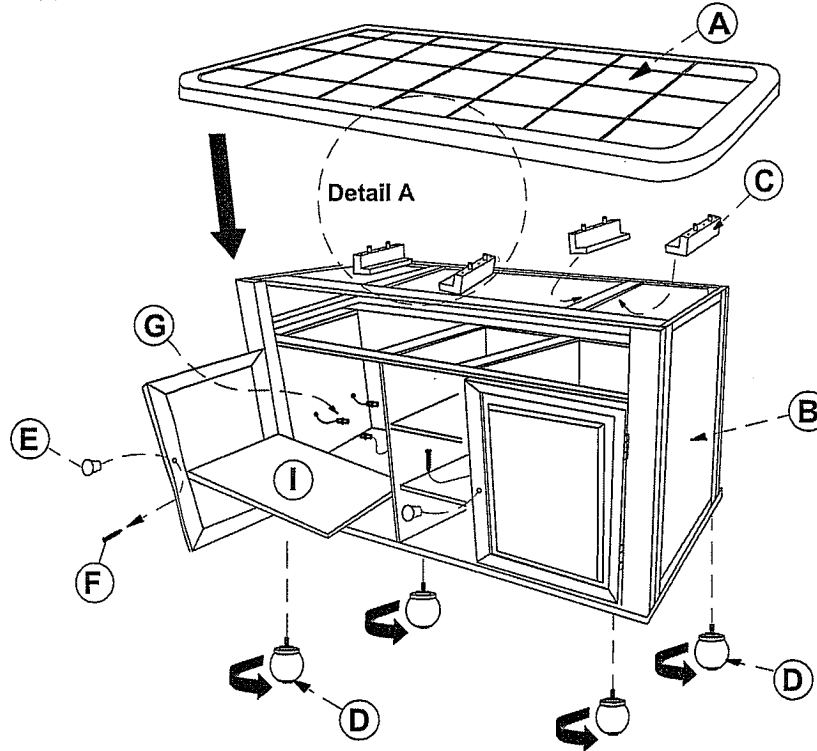

### Step: 3

- INSERT ADJUSTABLE (G) INTO UNIT AND PUT THE SHELF (I) TO INSIDE.
- ATTACH LEG (D) TO UNIT BY SCREWING ONE LEG INTO EACH CORNER OF BOTTOM PANEL, UNTIL TIGHT .

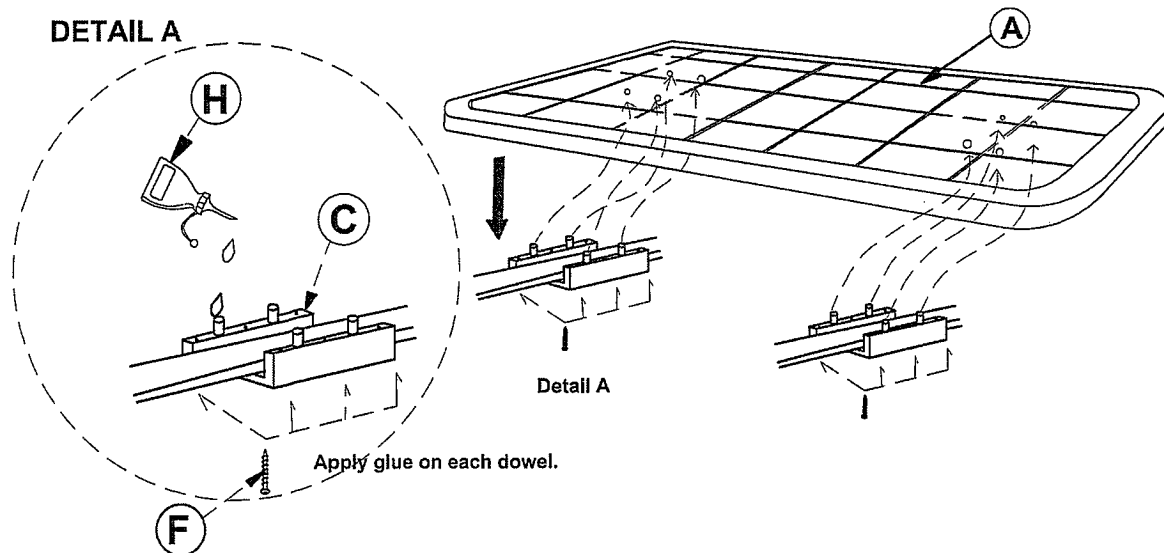

### Step: 4

- ALIGN TOP (A) TO THE CENTER OF UNIT AND ATTACH WOODEN SLIDE (C) BY SCREWING SCREW (F) UNTIL TIGHT.



**Sunset Trading®**

a div of Sunset Furniture Intl.LLC

11 Delta Dr  
Londonderry NH 03053  
877-364-8464

\*\*Pls Check to make sure you will have all parts otherwise contact local retailer or Sunset Trading customer service at 877-364-8464\*\*

# ASSEMBLY INSTRUCTIONS

KITCHEN ISLAND

24"W x 60-1/2"L x 35"H

Model : CY-KI-TT-02

Thank you for purchasing this Quality product. It has been engineered for easy assembly yet constructed for durability. Please take the time to read and follow the instructions while assembling.

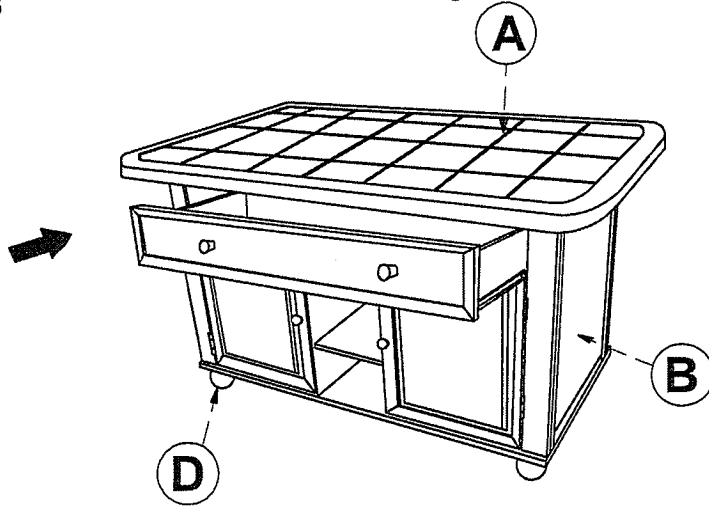

**Step: 5** - REINSTALL DRAWER INTO UNIT

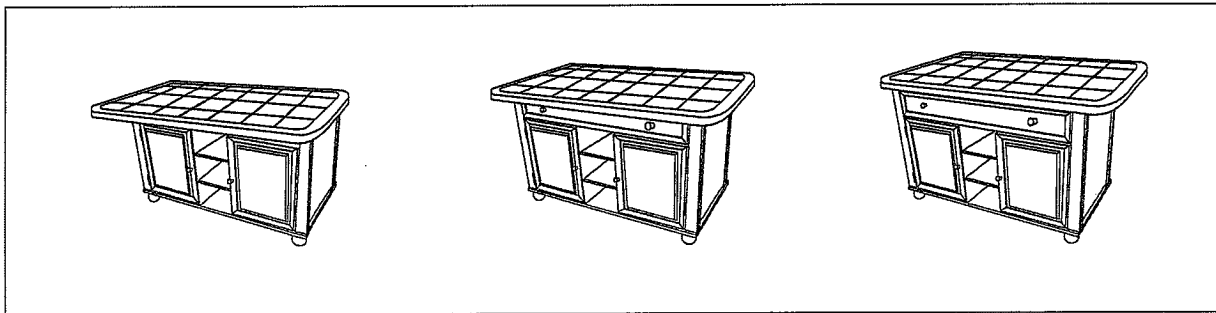

**FRONT**

**MIDDLE**

**BACK**

3 POSITION FIXED TOP AS SHOWN BY USING LATCH ON EACH BACK SIDE

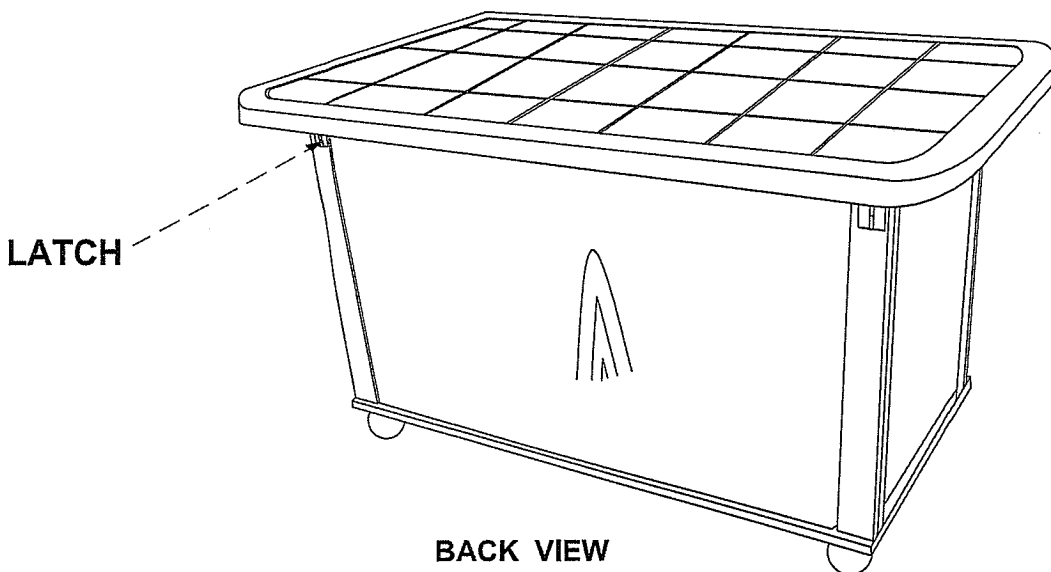



**Sunset Trading®**

a div of Sunset Furniture Intl.LLC

11 Delta Dr  
Londonderry NH 03053  
877-364-8464

\*\*Pls Check to make sure you will have all parts otherwise contact local retailer or Sunset Trading customer service at 877-364-8464\*\*

# ASSEMBLY INSTRUCTIONS

KITCHEN ISLAND

24"W x 60-1/2"L x 35"H

Thank you for purchasing this Quality product. It has been engineered for easy assembly yet constructed for durability. Please take the time to read and follow the instructions while assembling.

Model : CY-KI-TT-02

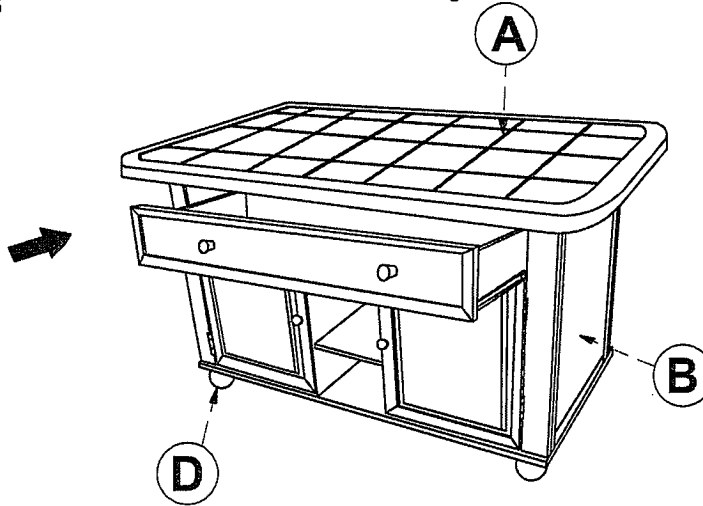

**Step: 5** - REINSTALL DRAWER INTO UNIT

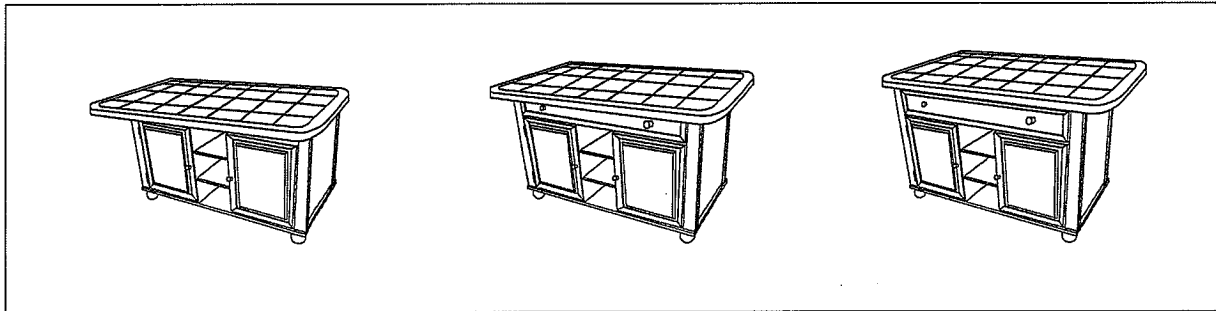

**FRONT**

**MIDDLE**

**BACK**

3 POSITION FIXED TOP AS SHOWN BY USING LATCH ON EACH BACK SIDE

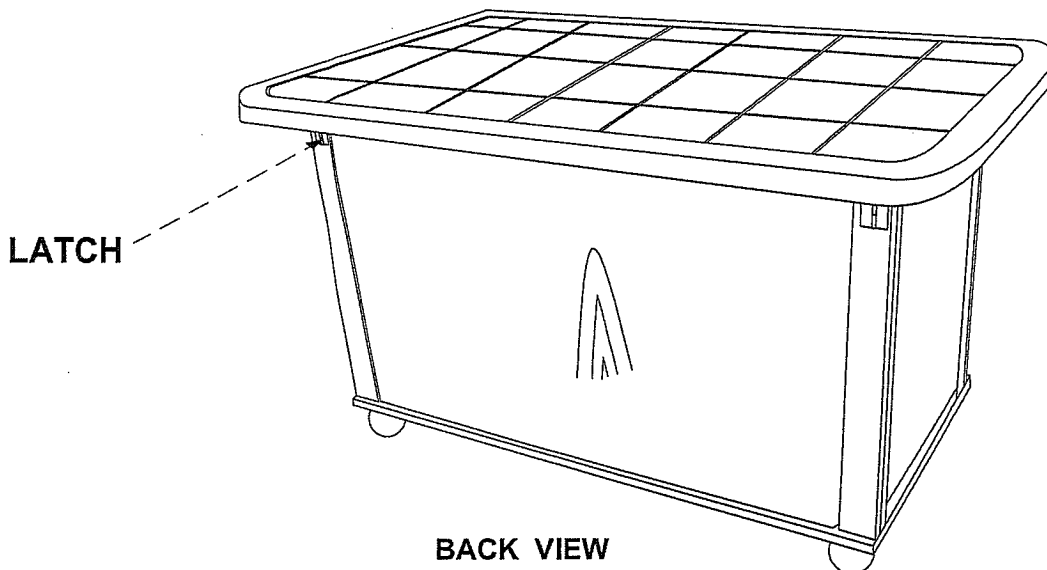



**Sunset Trading**  
a div of Sunset Furniture Intl, LLC

701 E Industrial PK Dr  
Manchester NH 03109  
877-364-8464

www.sunsettrading.com  
info@sunsettrading.com

\*\*Pls Check to make sure you have all parts otherwise contact local retailer or Sunset Trading customer service at 877-364-8464"

Thank You for purchasing this Quality product. It has been engineered for easy assembly yet constructed for durability. Please take the time to read and follow the instruction while assembling.

**ASSEMBLY INSTRUCTION**

EAST LANE STOOL 2 SLATS WITH HARD SEAT

17 3/4" x 22" x 40"H

Model : DLU-EL-B200-AG-RTA (CS1729-RTA)

**Step 1**

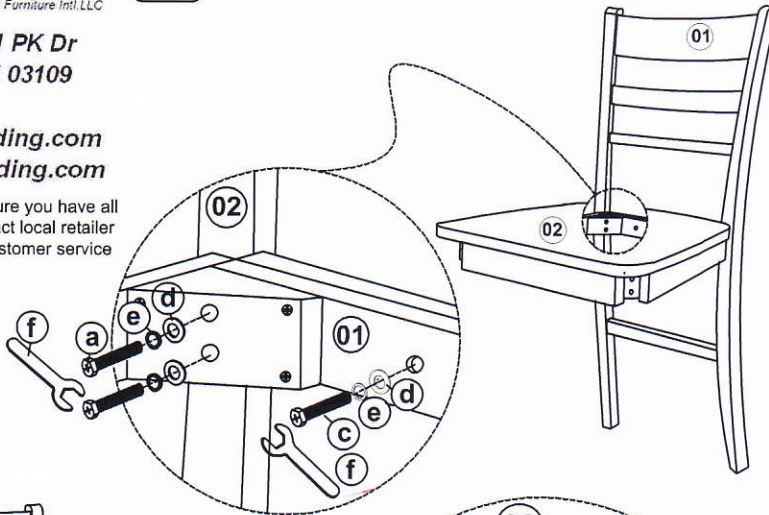

**Step 2**

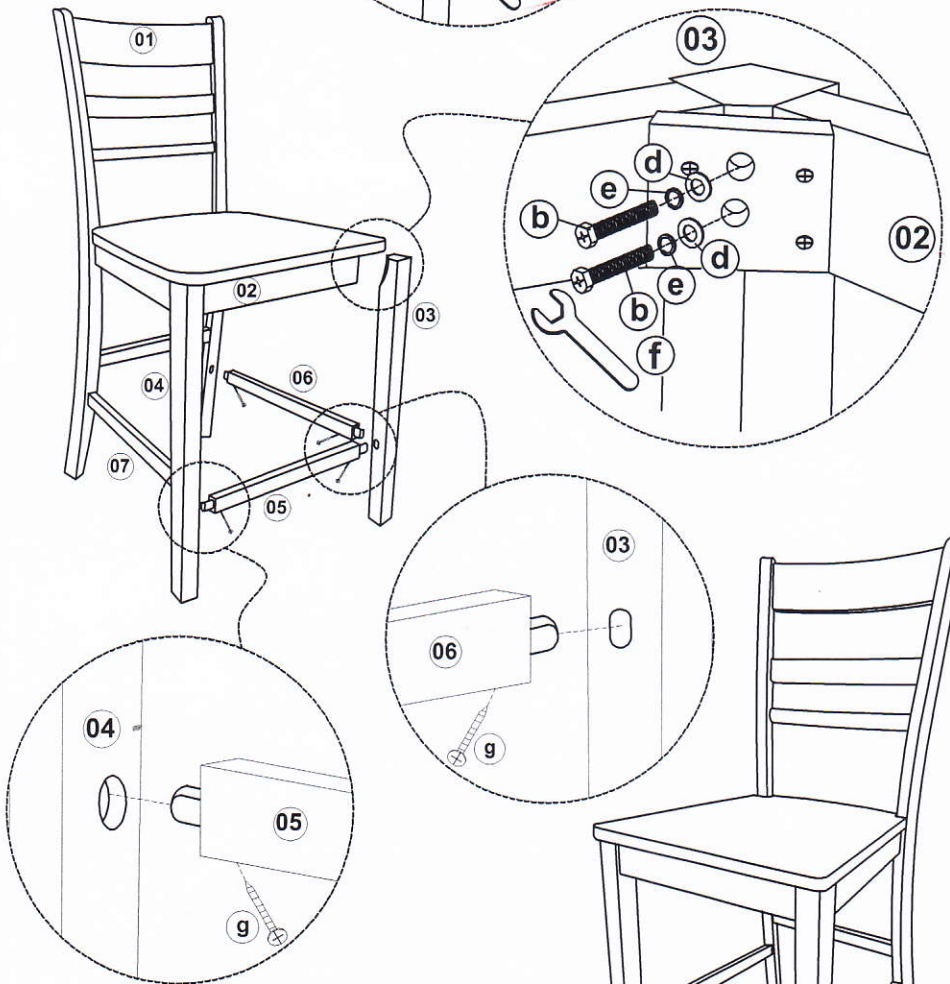

**List of Part For 1 Set**

Code	Figure	Part	Qty.
01		Chair Back	1
02		Seat	1
03		Front Leg (R)	1
04		Front Leg (L)	1
05		Front Stretcher	1
06		Side Stretcher (R)	1
07		Side Stretcher (L)	1

**List of hardware For 1 Set**

Code	Figure	Hardware	Qty.
a		Hex. Bolt M6 x 80mm	4
b		Hex. Bolt M6 x 60mm	4
c		Hex. Bolt M6 x 40mm	2
d		Flat Washer 1/4" x 18mm	10
e		Spring Washer 1/4"	10
f		Spanner 10mm	1
g		PHRS Screw #8 x 1 3/4"	6

**Important Notes**

- \* Keep all hardware parts out of reach of children.
- \* Must tighten screws periodically. With use screws will become loose. Check tightness of all screws every 6-8 weeks.
- \* Don't attempt to repair or modify parts that are broken or defective. Please contact the store immediately.
- \* Do not tighten all screw / bolt until all completely assembled.

**Notes**

- \* Place all wooden parts on a clean and smooth surface such as a rug or carpet to avoid the parts from being scratched.
- \* Check to be sure that you have all parts and hardware.
- \* Remove all wrapping materials including staples & packing straps before you start to assemble.
- \* Do not tighten all screws / bolts until all completely assembled.

**Care And Maintenance**

- \* The Touch of a soft cloth is all the maintenance your wood pieces will ever need.
- \* Never use harsh chemicals or abrasive cleaner as they could mark or destroy finish.

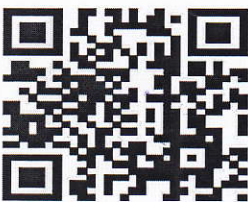

Assembly Completed !!...

