



**ITEM # VN340AC  
VENETO ACCENT CABINET  
34" X 16" X 29.25"**

Your furniture purchase is an investment. Here are a few tips to maximize the lifetime of your furniture with a minimal amount of effort. Properly caring for your furniture can help ensure that it looks great year after year.

**Wood Furniture Maintenance:**

- Always dust, wipe, and clean with the grain of the wood.
- Dust with a soft cloth. Dust will scratch the furniture surface if not removed properly.
- If a polished surface becomes cloudy, rub it with a cloth dipped in a solution of one tablespoon vinegar to one quart of water. Rub softly with the grain until the surface is completely dry.
- Soap and water are not advisable for wood surfaces. Water can penetrate the finish and raise the grain on wood, causing damage.
- Remember to change dusting cloths frequently as dirty cloths may scratch your furniture's surface.

**The Enemies of Wood:**

- Moisture is wood's worst enemy. Liquid spills should be gently wiped up immediately. Coasters should be used under all beverages.
- Do not allow rubber or vinyl materials to lie on the furniture. Chemicals in rubber may leave a stain. Put a strip of felt or leather under accessories that have rubber or vinyl.
- Heat creates a chemical change in the furniture's finish, which may result in a white spot. Use protective pads under hot dishes, appliances, etc.
- Sunlight's ultraviolet rays can damage the finish of furniture. Do not place furniture directly against a heater or radiator and do not place in the path of hot streams of air from central heating. This will cause extreme localized drying of the wood.

**Marble Top Maintenance:**

The surface of the marble on your table has been polished and sealed to create a generally non-porous surface. The stone has many natural characteristics including veining, hairline cracks, and color variations, which make up the stone's beauty.

**To maintain the beauty of your marble:**

- Protect surfaces from scratching, staining and etching by:
  - Keeping them free of debris or sharp objects.
  - Wiping up spills immediately
  - Avoiding contact with chemicals (particularly acid-based materials)
- Clean with PH neutral products or those especially formulated for use on stone.
- It is not recommended to use a water-based solvent for dark marble as it will remove the polish from the surface.

**Caring for the Fabric on Upholstered Furniture:**

- Frequent vacuuming of the entire upholstered area will prevent dust from settling into the fibers.
- Professional cleaning is always recommended for all upholstered pieces.
- Do not use cleaning products containing brightening agents.

<b>VERY IMPORTANT!!</b>			
<b>NEVER</b> USE GLASS CLEANERS ON FINISHED SURFACES. AMMONIA WILL CHEMICALLY ATTACK THE FINISH.	DO NOT WRITE DIRECTLY ON SURFACE  <b>PREVENT MARKING</b>	DO NOT PLACE DIRECTLY IN SUNLIGHT  <b>PREVENT FADING</b>	DO NOT USE PLACEMATS WITH RUBBER BASES  <b>PREVENT DISCOLORING</b>
<b>NEVER</b> ALLOW LIQUIDS OF ANY KIND TO LINGER ON SURFACES. ABSORPTION CAUSES THE WOOD TO WARP AND THE FINISH TO DE-LAMINATE.	DO NOT USE COMMERCIAL POLISHES AND WAXES  <b>PREVENT YELLOWING</b>	DO NOT PLACE HOT POTS, ETC ON SURFACE  <b>PREVENT DAMAGE TO FINISH!</b>	REGULATE THE HUMIDITY CONDITIONS AT YOUR HOME  <b>PREVENT SPLITTING</b>

ITEM # VN340AC

# Assembly Instruction

Put all screws in loosely at first.

Do not tighten screws & bolts until the entire item is completely assembled.

Note: More than 2 people assemble required

## STEP: 1

MATCH THE COLOR ARROWS  
TO ASSEMBLE THE LEGS

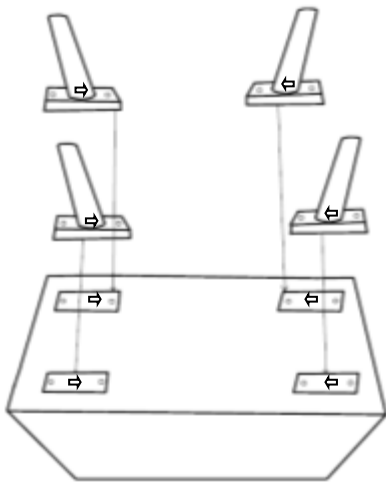

## STEP: 2 LOOSEN THE PRE-ASSEMBLY

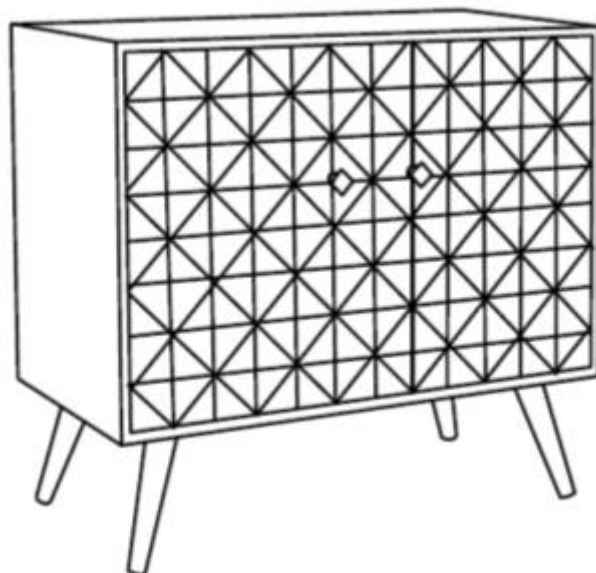
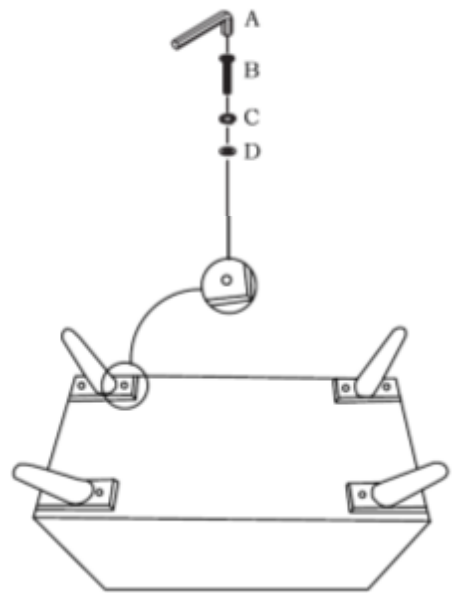

## Hardware Pack # PVN340ACH

A		4 MM	1 PC.
B		30 X 6 MM	8 PCS.
C		7 MM	8 PCS.
D		7 MM	8 PCS.

# PARTS FOR VN340AC

## COMPLETE HARDWARE # PVN340ACH

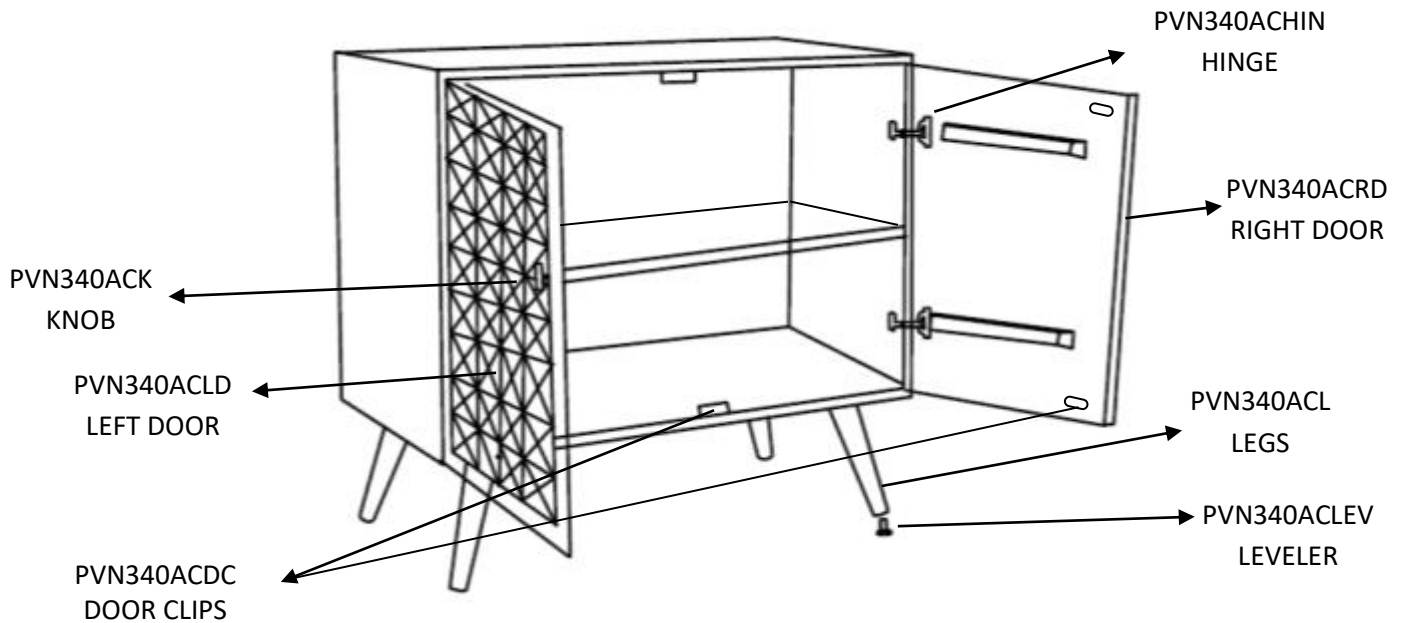

PRODUCT DETAILS	
CABINET	MANGO WOOD
BACK	MDF
DOOR	MANGO WOOD
KNOB	IRON
HINGES	IRON
LEGS	MANGO WOOD
FIXED SHELF	MANGO WOOD
LEVELER	PLASTIC + IRON
DOOR CLIPS	PLASTIC + MAGNET
PRODUCT SIZE	34" X 16" X 29.25"
CARTON SIZE	37" X 19.5" X 27"
NET WEIGHT	61.490 LBS
GROSS WEIGHT	74.470 LBS
CU. FT.	11.27
<b>MADE IN INDIA</b>	

# ANTI-TIPPING INSTRUCTIONS

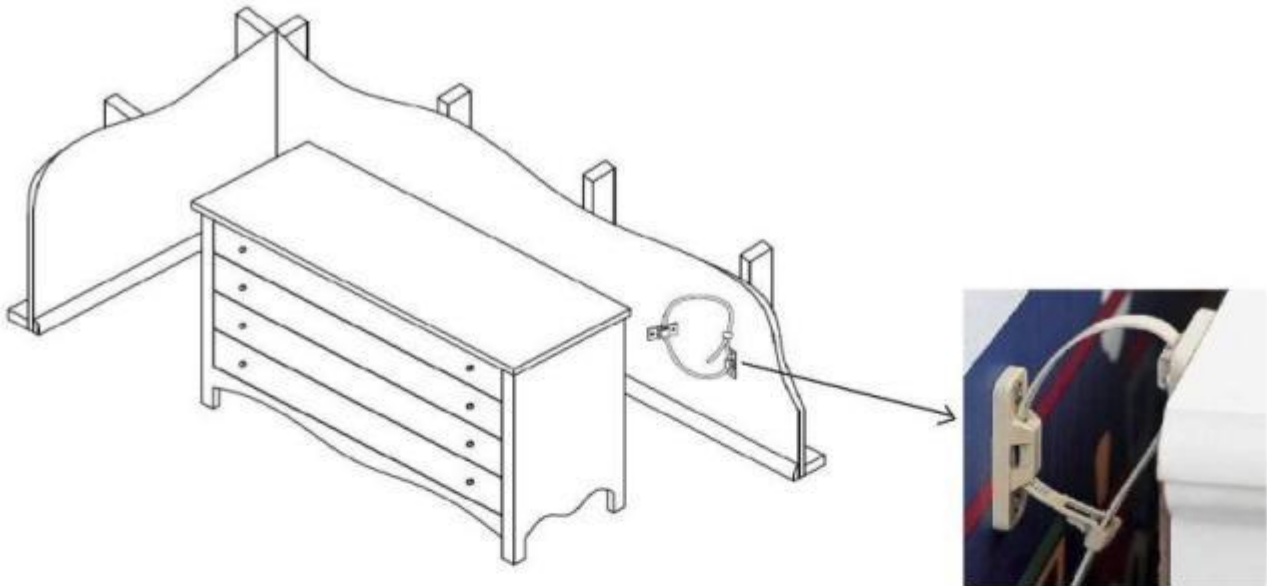

## Parts Enclosed:

Wallboards  
4pcs



Dry wall anchors  
4pcs



Long screws  
4pcs



Short screws  
4pcs



Straps  
2pcs



## Installation Instructions:

1. Using short screws, attach one of the wallboards toward one side of the rear of the furniture frame below the level of the top. Repeat this step for the opposite side of the back of the furniture frame.
2. Move furniture into its final position to measure and mark location to attach the wallboards to the wall. Then, move the furniture out the way so that the wallboards can then be mounted to the wall.
3. Attach the wallboards to the marked locations on the wall with long screws. Use dry wall anchors if you are mounting to dry wall.
4. Move the furniture into its final position. Thread the strap through the wallboards as shown above. Carefully tighten strap until snug, but do not overtighten.