



Item # : RU250A
 Description : Ruby Arm Chair
 Product Size : W 25"XD 25"XH 33"

Your furniture purchase is an investment. Here are a few tips to maximize the lifetime of your furniture with a minimum amount of effort. Properly caring for your furniture can help ensure that it looks great year after year.

Wood Furniture Maintenance:

- Always dust, wipe, and clean *with* the grain of the wood.
- Dust with a soft cloth. Dust will scratch the furniture surface if not removed properly.
- Use the same type of polish consistently as interchanging oil-based and wax-based polishes will cause a build-up and result in a foggy or cloudy appearance.
- If a polished surface becomes foggy, rub it with a cloth dipped in a solution of one tablespoon vinegar to one quart of water. Rub softly with the grain until the surface is completely dry.
- Soap and water are not advisable for wood surfaces. Water can penetrate the finish and raise the grain on wood, causing damage.
- Remember to change dusting cloths frequently as dirty cloths may scratch your furniture's surface.

The Enemies of Wood:

- Moisture is wood's worst enemy. Liquid spills should be gently wiped up immediately. Coasters should be used under all beverages.
- Do not allow rubber or vinyl materials to lie on the furniture. Chemicals in rubber may leave a stain. Put a strip of felt or leather under accessories that have rubber or vinyl.
- Heat creates a chemical change in the furniture's finish, which results in a white spot. Use protective pads under hot dishes, appliances, etc.
- Sunlight's ultraviolet rays can damage the finish of furniture. Do not place furniture directly against a heater or radiator and do not place in the path of hot streams of air from central heating. This will cause extreme localized drying of the wood.

High Gloss Resin Table Maintenance:

- Resin tabletops have approximately 1/8" of a resin coat on the top face of the table, which will resist ice, water, wine, liquor, food, cleaning fluids, and warm or hot liquids; however, cups, glasses, etc. containing hot liquids should not be left on the table without a coaster for protection.
- Resin tabletops will scratch just the same as any other glossy surface and basic precautions should be taken.
- For lasting shine, the resin table should be waxed with a car wax that does not contain silicon. Maintaining this wax build-up will result in a high gloss shine.
- When wiping down the table, a soft, clean rag should be used. Do not use a heavy paper.

Granite Top Maintenance:

- The surface of the granite on your table has been polished or sealed to create a generally non-porous surface. The stone has many natural characteristics including: veining, hairline cracks, and color variations - which make up the stone's beauty.
- To maintain the beauty of your granite:
 - Protect surfaces from scratching, staining and etching by:
 - * Keeping them free of debris or sharp objects
 - * Wiping up spills immediately
 - * Avoiding contact with chemicals (particularly acid-based materials) or those especially formulated for use on stone.
 - It is not recommended to use a water-based solvent for dark granite as it will remove the polish from the surface.
 - After a period of use, apply a penetrating sealer to prevent contaminants from being absorbed into the stone.
 - Remove stains with special absorbent poultices formulated for use on stone.
 - Renew the surface on *polished* granite (granite with a high gloss surface) by buffing with special stone polish, powder or cream.
- Do not use granite polish on granite with a matte finish, which has been honed rather than polished. (Penetrating sealer may be used on both polished and honed granite.)







Marble Top Maintenance:

- Marble may be stone, but it is porous stone and can stain easily. Treating marble surfaces the same as wood surfaces is a great rule of thumb.
- It is recommended to seal the tops on a regular basis (every 6 to 12 months). A good quality stone sealer can be purchased from any tiles/stone store or any homecare store and should be applied according to the manufacturer's recommendation.
- When sealed properly, marble tops can be used indoors and outdoors and can withstand any weather conditions except internal freezing. Snow or freezing rain will penetrate the table and cause cracks.

Caring for the Fabric on Upholstered Furniture:

- Frequent vacuuming of the entire upholstered area will prevent dust from settling into the fibers.
- Professional cleaning is always recommended for all upholstered pieces.
- Always pre-test a small area of fabric in an inconspicuous area when cleaning before proceeding.
- Do not use cleaning products containing brightening agents.

VERY IMPORTANT!!

| | | | |
|--------------------------------------------------------------------------------------------------------------------------------------------|---------------------------------------------------------------------------------------------------------------------------------------------------------------------|----------------------------------------------------------------------------------------------------------------------------------------------------------------------------|----------------------------------------------------------------------------------------------------------------------------------------------------------------------------|
| <p>NEVER USE GLASS CLEANERS ON FINISHED SURFACES. AMMONIA WILL CHEMICALLY ATTACK THE FINISH.</p> | <p>DO NOT WRITE DIRECTLY ON SURFACE </p> <p>PREVENT MARKING</p> | <p>DO NOT PLACE DIRECTLY IN SUNLIGHT </p> <p>PREVENT FADING</p> | <p>DO NOT USE PLACEMATS WITH RUBBER BASES </p> <p>PREVENT DISCOLORING</p> |
| <p>NEVER ALLOW LIQUIDS OF ANY KIND TO LINGER ON SURFACES. ABSORPTION CAUSES THE WOOD TO WARP AND THE FINISH TO DE-LAMINATE.</p> | <p>DO NOT USE COMMERCIAL POLISHES AND WAXES </p> <p>PREVENT YELLOWING</p> | <p>DO NOT PLACE HOT POTS, ETC. ON SURFACE </p> <p>PREVENT DAMAGE TO FINISH!</p> | <p>REGULATE THE HUMIDITY CONDITIONS AT YOUR HOME </p> <p>PREVENT SPLITTING</p> |

ASSEMBLY INSTRUCTIONS

Two people are recommended to the assembly

Do not tighten bolts until the entire item is completely assembled

STEP:1

Attach LSF Arm Rail(#B) and RSF Arm Rail (#C) to the Chair Seat (#A) using Long Bolt(#1),Spring Washer (#3) and Large Flat Washer(#2),tighten with Allen Key (#6).

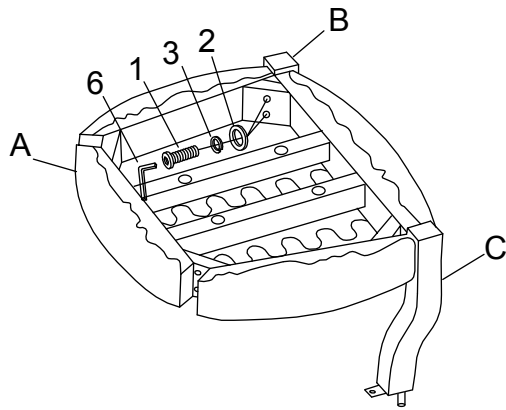

STEP:2

Attach the 2 of Back Rail (#D) to the Chair Seat (#A) using Long Bolt(#1), Spring Washer(#3) and Large Flat Washer(#2),tighten with Allen Key (#6).

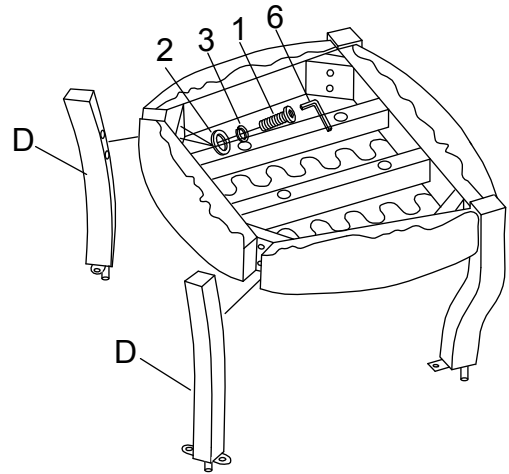

STEP:3

Connect the Backrest (#E) to the rail (#B,C,D) by inserting Small Flat Washer (#5) and short Bolt (#4) into the holes located at the leg and Backrest (#E), tighten with Allen Key (#6).

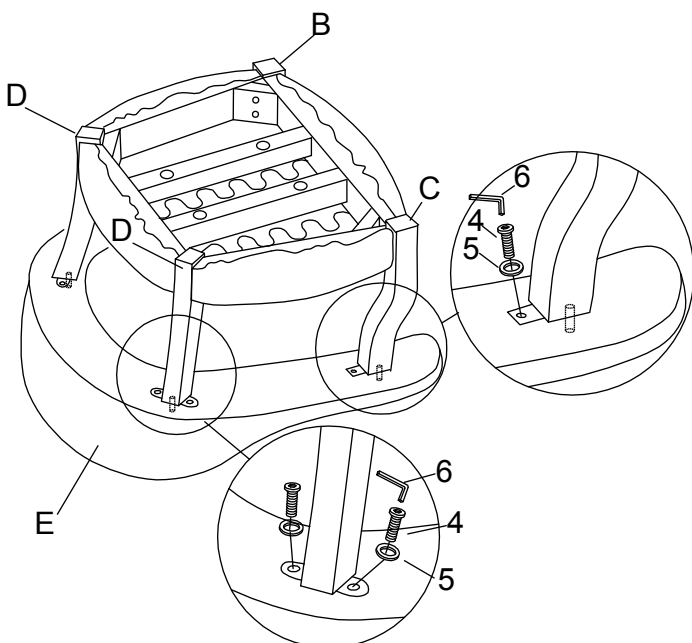

STEP: 4

Attach the Swivel Mechanism (#F) to the Chair Seat (#A) by inserting Large Flat Washer (#2) and Medium Bolt (#7) into the holes located at the Chair Seat (#A), tighten with Allen Key (#6).

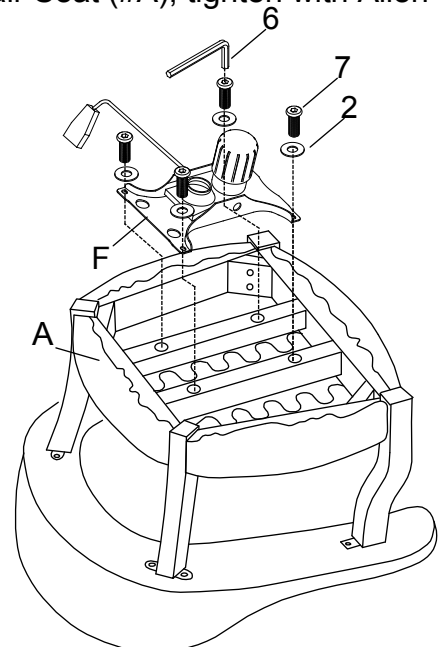

ASSEMBLY INSTRUCTIONS

Two people are recommended to the assembly

Do not tighten bolts until the entire item is completely assembled

STEP:5

Install the Caster (#I) by lining up the stem and pressing into the designated spot on the Chair Base (#H). Insert Cylinder (#G) into the hole of the Chair Base (#H) as shown.

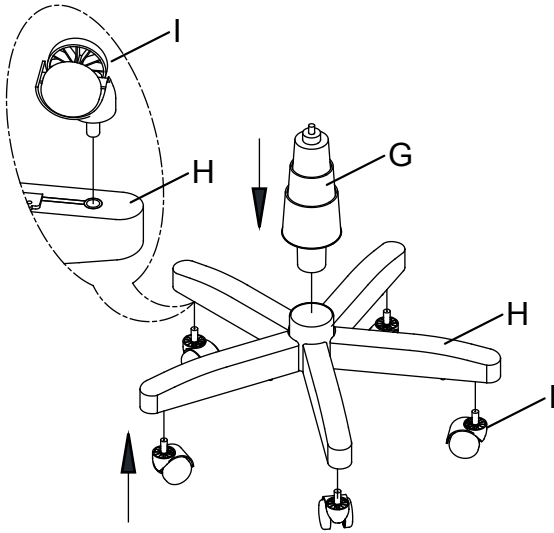





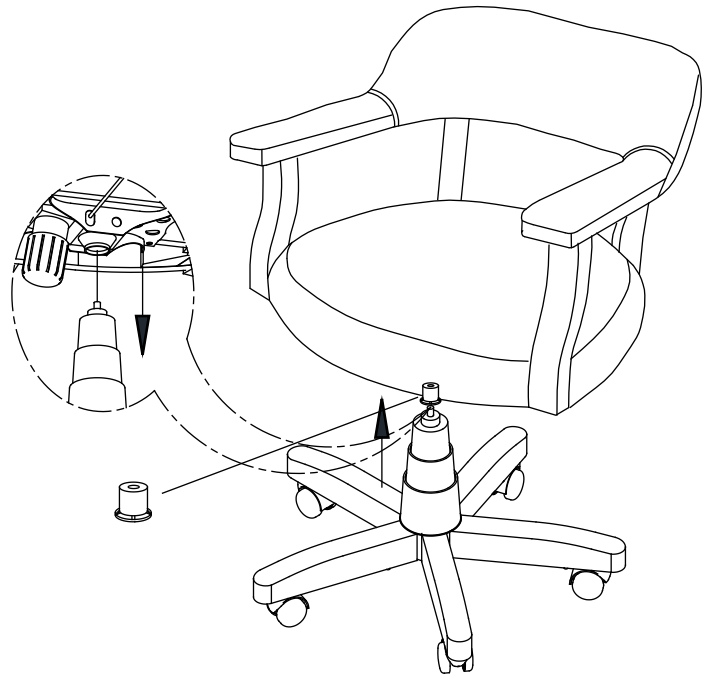

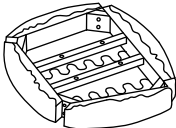
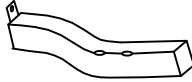

STEP:6

Remove protective cap before placing seat on base. Then place the assembly Chair seat in step 4 onto the assembly Chair base in step 5. Assembly product is now completed.



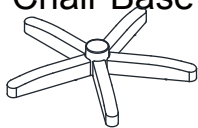



PARTS LIST

| | |
|-------------------------------------------------------------------------------------------------------------------|-------------------------------------------------------------------------------------------------------------------------|
| <p>(A) Chair Seat (1PC)</p>  | <p>(B) LSF Arm Rail (1PC)</p>  |
| <p>(C) RSF Arm Rail (1PC)</p>  | <p>(D) Back Rail (2PC)</p>  |
| <p>(E) Backrest (1PC)</p>  | <p>(F) Swivel Mechanism (1PC)</p>  |
| <p>(G) Cylinder (1PC)</p>  | <p>(H) Chair Base (1PC)</p>  |
| <p>(I) Caster (5PCS)</p>  | |

ASSEMBLY INSTRUCTIONS

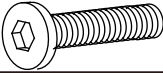
Two people are recommended to the assembly

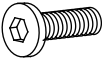
HARDWARE PACK # : PRU250AH

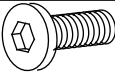

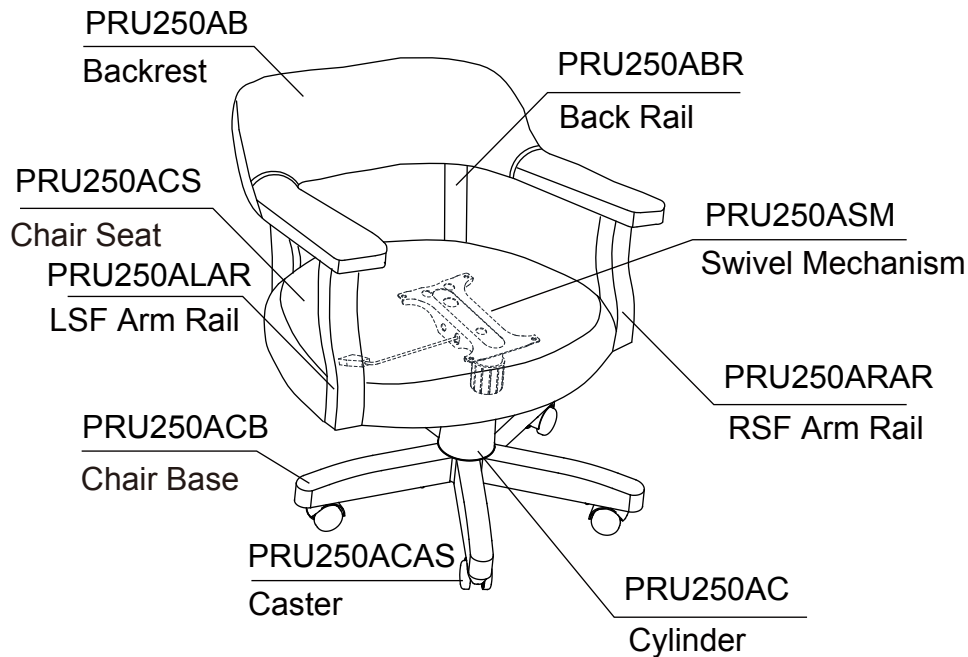

| NO. | Description | | Size | Q'ty |
|-----|-------------------|-----------------------------------------------------------------------------------|-----------|-------|
| 1 | Long Bolt |  | 5/16"x2" | 8Pcs |
| 2 | Large Flat Washer |  | 5/16" | 12Pcs |
| 3 | Spring Washer |  | 5/16" | 8Pcs |
| 4 | Short Bolt |  | 1/4"x3/4" | 6Pcs |
| 5 | Small Flat Washer |  | 1/4" | 6Pcs |
| 6 | Allen Key |  | M4 | 1Pc |
| 7 | Medium Bolt |  | 5/16"x1" | 4Pcs |



| PRODUCT DETAILS | |
|-----------------|--------------------------|
| Chair Back | Solid Wood+PU+Foam |
| Chair Seat | Solid Wood+PU+Foam |
| Chair Base | Solid Wood+Plastic+Metal |
| PRODUCT SIZE | W 25"XD 25"XH 32.5" |
| CARTON SIZE | W 29"XD 27"XH 11.5" |
| NET WEIGHT | 39.6 LBS |
| GROSS WEIGHT | 44 LBS |
| CUFT/CTN | 5.2' / 1PC |

PU CONTENT : 15% Polyurethane+40% Backer+45% PVC
 This pu is not machine washable.
 allow +/-3% residual shrinkage.

Do not use cleaning products containing brightening agents.
 Do not mix fabric of different colors.
 The fabric is suitable for drapery and upholstery.

Steve Silver Company Dining Chairs – Assembly Troubleshooting Guide

The most important element of correct chair assembly is to tighten the bolts as directed. Prematurely tightening the bolts can lead to numerous issues and will lengthen the assembly time. Listed below are the most common issues in chair assembly and their easy solutions.

PROBLEM: Chair is unlevel.

Cause 1:

Unlevel chairs can occur if the bolts are fully tightened before all bolts are attached. There is a variance in the alignment of this chair to allow the chair to be assembled more easily.

Solution:

Loosen each bolt in the seat box (front legs, back corner blocks and back apron) until they are finger tight. Place the chair upright on the floor. Sit in the chair for about 30 seconds. Carefully turn the chair upside down and tighten each bolt. The chair will now be level.

Cause 2:

Unlevel chairs can occur if one or more of the floor glides are missing from the bottom of the chair leg.

Solution:

Request a set of floor glides from the e-mail address below.

AR@ssilver.com

PROBLEM: Bolts do not fit properly.

Cause:

This issue can occur when the bolts are tightened fully before all bolts are attached. There is a variance in the alignment of the bolts to allow the chair to be assembled more easily.

Tightening the bolts prematurely can cause the holes for the other bolts to become slightly misaligned, causing the remaining bolts not to fit properly.

Solution:

Make sure each bolt in the seat box (front legs, back corner blocks and back apron) is loosened until finger tight. This will allow you to realign the holes, and the bolts will now fit properly.

Questions?

Please call us at 1 800 344 7278, and we will be happy to help you.