



**Item #:** HU500TT / HU500TB  
**Description:** HUTCHINS TABLE TOP/ TABLE BASE  
**Product Size:** 42" x 95.25" x 30"H (2 LEAF 18")

Your furniture purchase is an investment. Here are a few tips to maximize the lifetime of your furniture with a minimum amount of effort. Properly caring for your furniture can help ensure that it looks great year after year.

#### Wood Furniture Maintenance:

- Always dust, wipe, and clean *with* the grain of the wood.
- Dust with a soft cloth. Dust will scratch the furniture surface if not removed properly.
- Use the same type of polish consistently as interchanging oil-based and wax-based polishes will cause a build-up and result in a foggy or cloudy appearance.
- If a polished surface becomes foggy, rub it with a cloth dipped in a solution of one tablespoon vinegar to one quart of water. Rub softly with the grain until the surface is completely dry.
- Soap and water are not advisable for wood surfaces. Water can penetrate the finish and raise the grain on wood, causing damage.
- Remember to change dusting cloths frequently as dirty cloths may scratch your furniture's surface

#### The Enemies of Wood:

- Moisture is wood's worst enemy. Liquid spills should be gently wiped up immediately. Coasters should be used under all beverages.
  - Do not allow rubber or vinyl materials to lie on the furniture. Chemicals in rubber may leave a stain. Put a strip of felt or leather under accessories that have rubber or vinyl.
- Heat creates a chemical change in the furniture's finish, which results in a white spot. Use protective pads under hot dishes, appliances, etc.
- Sunlight's ultraviolet rays can damage the finish of furniture. Do not place furniture directly against a heater or radiator and do not place in the path of hot streams of air from central heating. This will cause extreme localized drying of the wood.

#### High Gloss Resin Table Maintenance:

- Resin tabletops have approximately 1/8" of a resin coat on the top face of the table, which will resist ice, water, wine, liquor, food, cleaning fluids, and warm or hot liquids; however, cups, glasses, etc. containing hot liquids should not be left on the table without a coaster for protection.
- Resin tabletops will scratch just the same as any other glossy surface and basic precautions should be taken.
- For lasting shine, the resin table should be waxed with a car wax that does not contain silicon. Maintaining this wax build-up will result in a high gloss shine.
- When wiping down the table, a soft, clean rag should be used. Do not use a heavy paper.

#### Granite Top Maintenance:

The surface of the granite on your table has been polished or sealed to create a generally non-porous surface. The stone has many natural characteristics including: veining, hairline cracks, and color variations - which make up the stone's beauty.

To maintain the beauty of your granite:

- Protect surfaces from scratching, staining and etching by:
  - \* Keeping them free of debris or sharp objects
  - \* Wiping up spills immediately
  - \* Avoiding contact with chemicals (particularly acid-based materials)
- Clean with pH neutral products or those especially formulated for use on stone.
- It is not recommended to use a water-based solvent for dark granite as it will remove the polish from the surface. Absorbed into the stone.
- After a period of use, apply a penetrating sealer to prevent contaminants from being
- Remove stains with special absorbent poultices formulated for use on stone.
- Renew the surface on polished granite (granite with a high gloss surface) by buffing with special stone polish, powder or cream.

Do not use granite polish on granite with a matte finish, which has been honed rather than polished. (Penetrating sealer may be used on both polished and honed granite.)

#### Marble Top Maintenance:

Marble may be stone, but it is porous stone and can stain easily. Treating marble surfaces the same as wood surfaces is a great rule of thumb.

- It is recommended to seal the tops on a regular basis (every 6 to 12 months).
- A good quality stone sealer can be purchased from any tiles / stone store or any homeware store and should be applied according to the manufacturer's recommendation.

- When sealed properly, marble tops can be used indoors and outdoors and can withstand any weather conditions except internal freezing. Snow or freezing rain will penetrate the table and cause cracks.

#### Caring for the Fabric on Upholstered Furniture:

- Frequent vacuuming of the entire upholstered area will prevent dust from settling into the fibers.
- Professional cleaning is always recommended for all upholstered pieces.
- Always pre-test a small area of fabric in an inconspicuous area when cleaning before proceeding.
- Do not use cleaning products containing brightening agents.

## VERY IMPORTANT!!

### NEVER

USE GLASS CLEANERS ON FINISHED SURFACES. AMMONIA WILL CHEMICALLY ATTACK THE FINISH.

DO NOT WRITE DIRECTLY ON SURFACE



PREVENT MARKING

DO NOT PLACE DIRECTLY IN SUNLIGHT



PREVENT FADING

DO NOT USE PLACEMATS WITH RUBBER BASES



PREVENT DISCOLORING

### NEVER

ALLOW LIQUIDS OF ANY KIND TO LINGER ON SURFACES. ABSORPTION CAUSES THE WOOD TO WARP AND THE FINISH TO DE-LAMINATE.

DO NOT USE COMMERCIAL POLISHES AND WAXES



PREVENT YELLOWING

DO NOT PLACE HOT POTS, ETC. ON SURFACE



PREVENT DAMAGE TO FINISH!

REGULATE THE HUMIDITY CONDITIONS AT YOUR HOME



PREVENT SPLITTING

# HU500TT / HU500TB

## ASSEMBLY INSTRUCTIONS

**DO NOT FULLY TIGHTEN ALL BOLTS AND HEX NUTS UNTIL THE ENTIRE UNIT IS COMPLETELY ASSEMBLED**

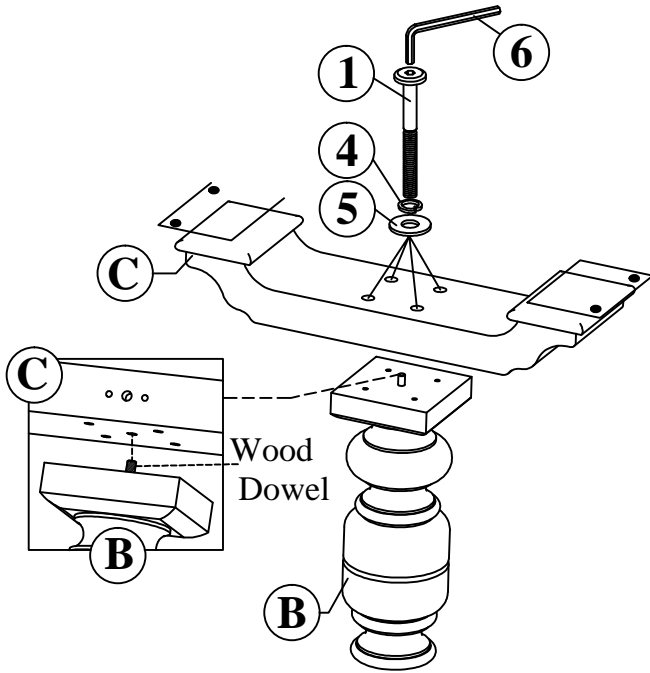

Step 1: Attach the Table Leg (B) to the Leg Frame (C) by aligning the Wood Dowel on the Table Leg (B) to the center hole on the Leg Frame (C) as the picture shown.

Inserting Long Bolt (1), Lock Washer (4), Flat Washer (5) and tighten with Allen Key (6). Do not fully tighten.

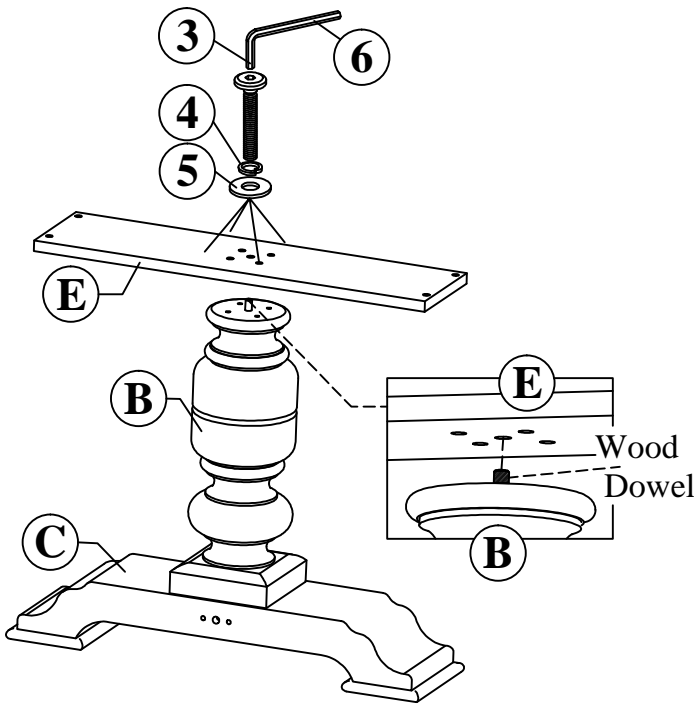

Step 2: Attach the Mounting Panel (E) to the Table Leg (B) by aligning the Wood Dowel on the Table Leg (B) to the center hole on the Mounting Panel (E) as the picture shown.

Inserting Short Bolt (3), Lock Washer (4), Flat Washer (5) and tighten with Allen Key (6). Do not fully tighten.

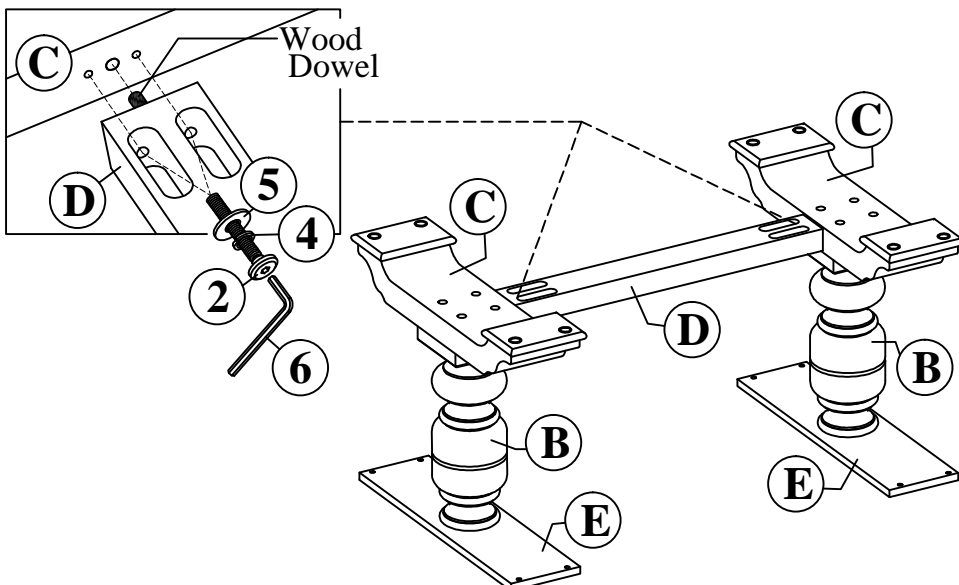

Step 3: Attach the Center Stretcher (D) to the Middle of Leg Frame (C) by aligning the Wood Dowel on the Center Stretcher (D) to the center hole on the Leg Frame (C) as the picture shown.

Inserting Medium Bolt (2), Lock Washer (4), Flat Washer (5) and tighten with Allen Key (6).

Fully tighten all Bolts in Step 1;2;3 at this time. Do not over tighten.

# HU500TT / HU500TB ASSEMBLY INSTRUCTIONS

**DO NOT FULLY TIGHTEN ALL BOLTS AND HEX NUTS UNTIL THE ENTIRE UNIT IS COMPLETELY ASSEMBLED**

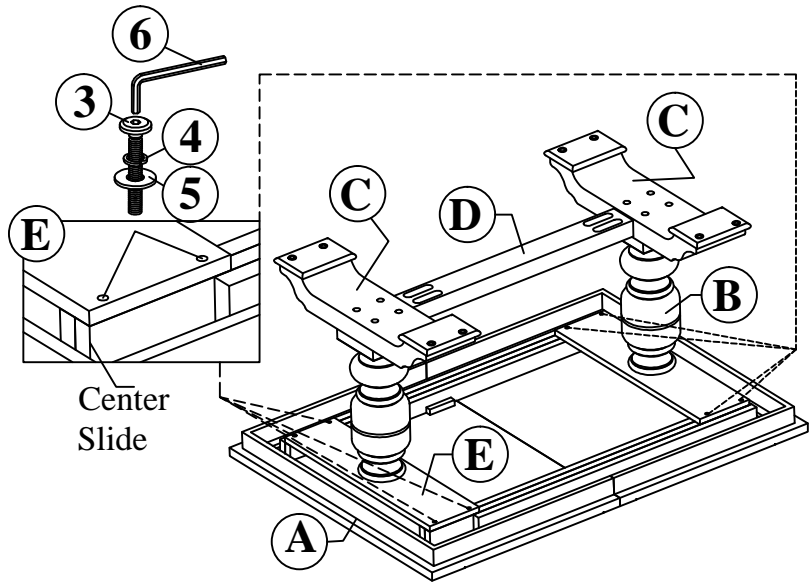

**Step 4:** Place the Table Top (A) on the floor. Attach the Assenbly Base in Step 3 by inserting Short Bolt (3), Lock Washer (4), Flat Washer (5).

Fully tighten these Bolts with Allen Key (6). Do not over tighten.

**Step 5:** Turn the Table to upright position. If using 1 Leaf, unlock the Latch underneath the Table Top (A) and open the Table Top, inserting the Table Leaf (F) into the middle of the Table Top (A), close the Table Top (A) by pushing from both ends. Lock the Latch underneath the Table Top (A) to prevent from sliding.

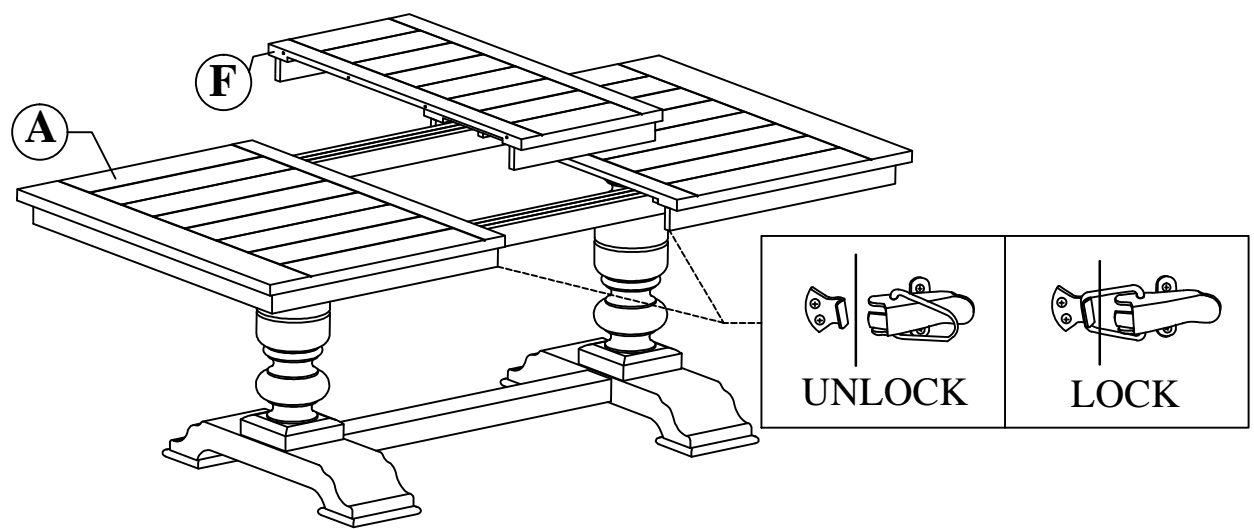



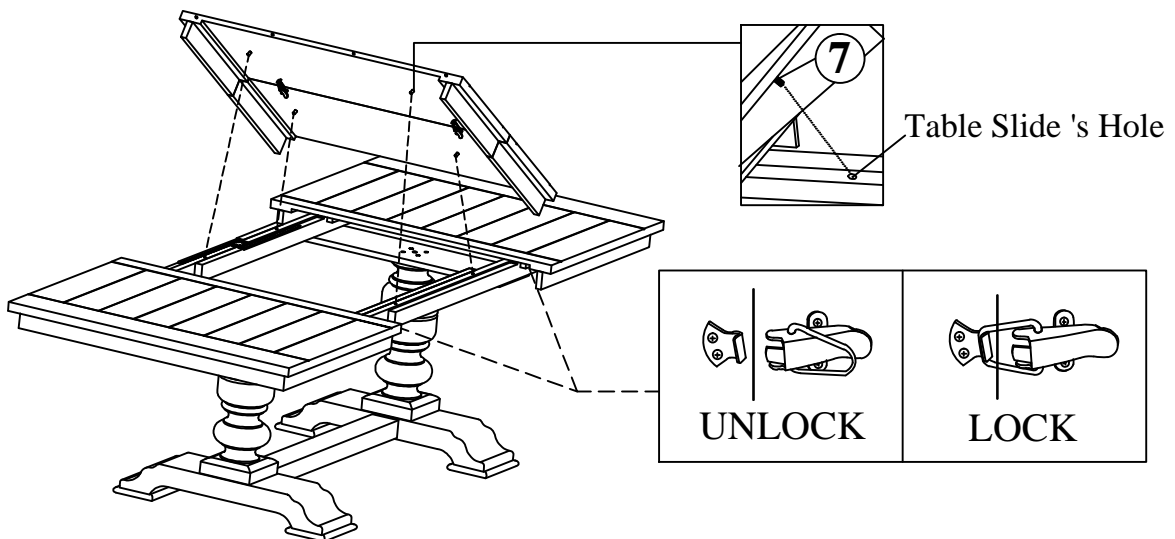

**Step 5:** If using 2 Leaf, attach two Table Leaf (B) together and insret the Wood Dowel (7) into the dre-drill hole on the Table Leaf (F). Unlock the Latch underneath the Table Top (A) and open the Table Top, insert the 2 Table Leaf (F) into the middle of the Table Top (A) by aligning the Wood Dowel (7) in to the holes of the Table Slide as the picture bellow. Close the Table Top (A) by pushing from both ends. Lock the Latch underneath the Table Top (A) to prevent from sliding. Assebly is now completed.

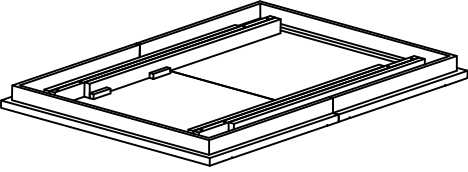
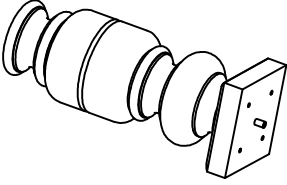
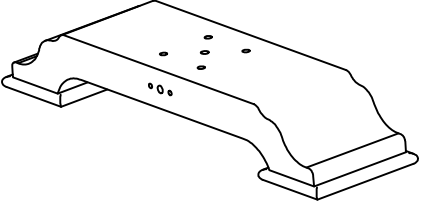
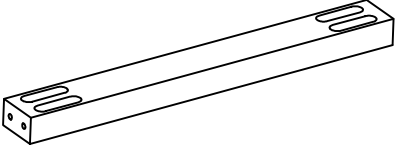
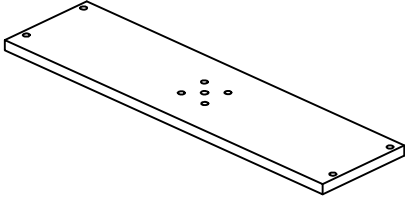
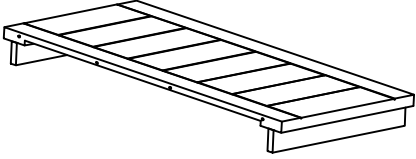

## PART LIST

(A) TABLE TOP (1PC)	(B) TABLE LEG (2PCS)	(C) LEG FRAME (2PCS)
		
(D) CENTER STRETCHER (1PC)	(E) MOUNTING PANEL (2PCS)	(F) TABLE LEAF (2PCS)
		

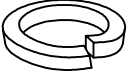
### HARDWARE PACK # : PHU500TBH

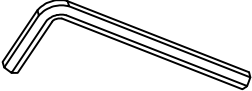
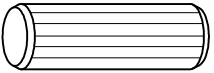
NO.	DESCRIPTION	DIMENSION	Q'TY
1	Long Bolt	 $\Phi 5/16"$ x 70 mm	8 pcs
2	Medium Bolt	 $\Phi 5/16"$ x 60 mm	4 pcs
3	Short Bolt	 $\Phi 5/16"$ x 50 mm	16 pcs
4	Lock Washer	 $\Phi 5/16"$ x 13 mm	28 pcs
5	Flat Washer	 $\Phi 5/16"$ x 13 mm	28 pcs
6	Allen Key	 4 mm	1 pc
7	Wood Dowel	 $\Phi 8$ x 20 mm	4 pcs

**PARTS FOR HU500TT / HU500TB  
COMPLETE HARDWARE # : PHU500TBH**

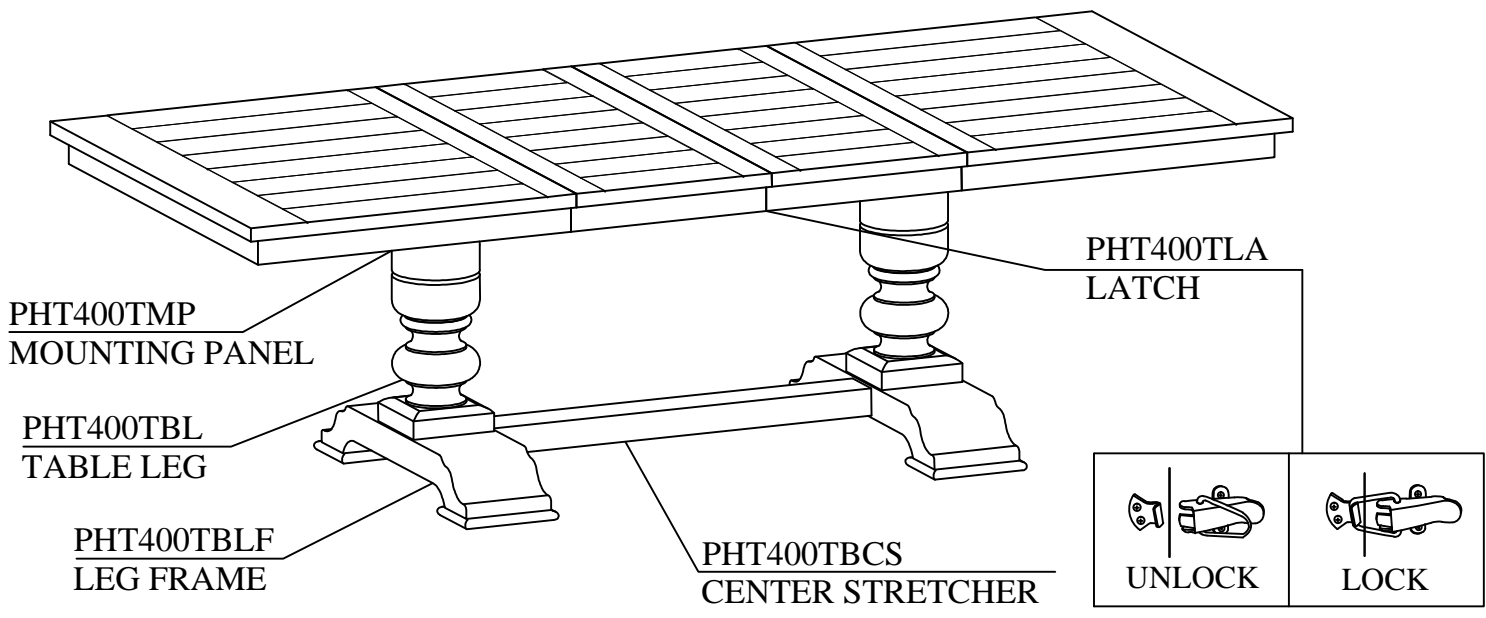

**PRODUCT DETAILS**

TOP	MDF/ OAK VENEER
APRON	RUBBER WOOD/ MANGO WOOD
LEG	ACACIA WOOD
LEG FRAME	ACACIA WOOD
STRETCHER	MANGO WOOD
PRODUCT SIZE	42" x 95.25" x 30"H (2 LEAF 18")
CARTON SIZE TOP	62.38" x 45.25" x 8.25"H
CARTON SIZE BASE	36.0" x 34.50" x 10.50"H
NET WEIGHT TOP	136.4 LBS
NET WEIGHT BASE	57.2 LBS
GROSS WEIGHT TOP	151.8 LBS
GROSS WEIGHT BASE	66 LBS
CU.FT. TOP	13.48'
CU.FT. BASE	7.55'

**MADE IN VIETNAM**