

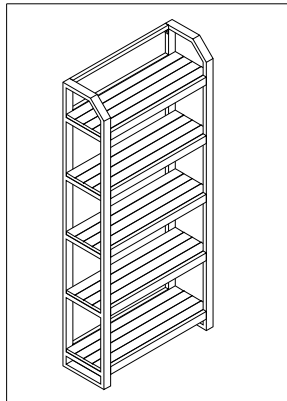

ASSEMBLY INSTRUCTION #2835



HARDWARE LIST

NO	SKETCH	HARDWARE	QTY
1		JCBC M6 x 35	20 pcs
2		JCBC M6 x 20	6 pcs
3		Spring washer	26 pcs
4		Flat washer	26 pcs
5		Allen key	1 pc

ANTITIPPING LIST

NO	SKETCH	HARDWARE	QTY
4		Screw Ø8 x 2"	1 Pc
5		Screw Ø8 x 3/4"	1 Pc
6		Metal Anchor	2 Pcs
7		Restrain Strap	1 Pc
8		Fischer	1 Pc

PART LIST

NO	DESCRIPTION	SKETCH	QTY
A	Metal side frame L		1 Pc
B	Metal side frame R		1 Pc
C	Shelf		5 Pcs
D	Metal back frame		3 Pcs

ASSEMBLY STEP

STEP 1

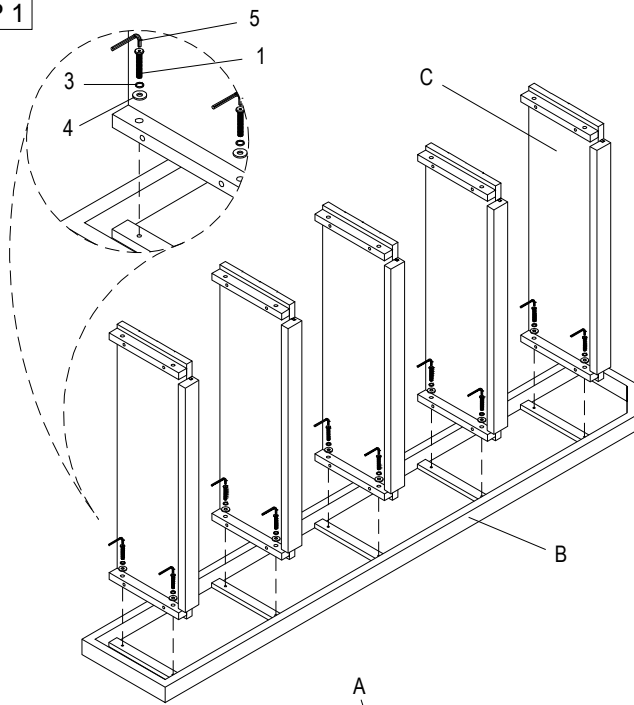

STEP 2

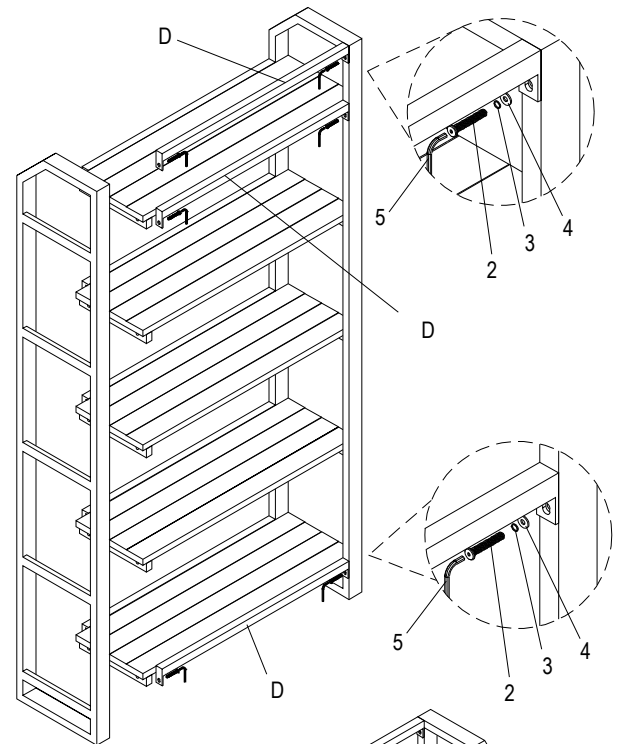

STEP 3

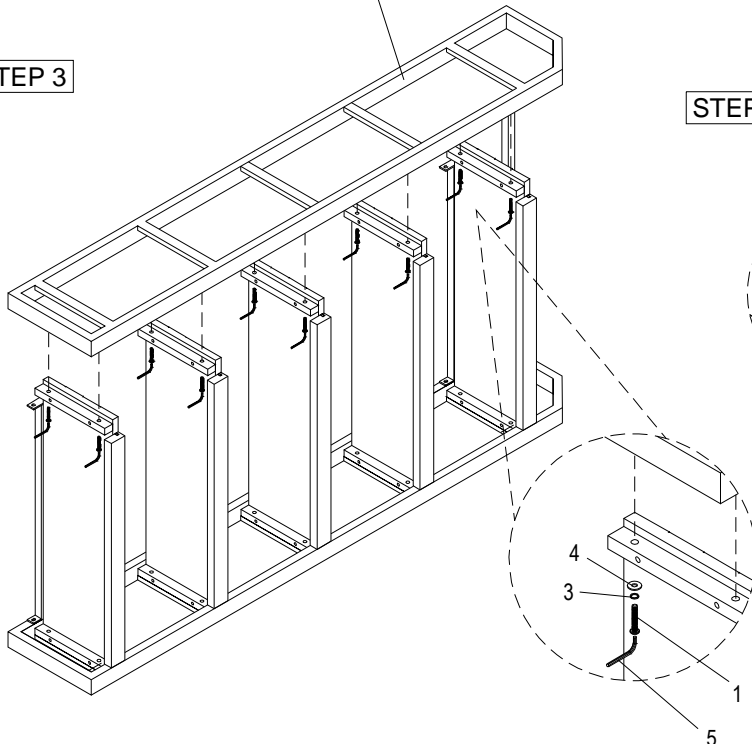

STEP 4

