







ASSEMBLY INSTRUCTIONS #2029

HARDWARE LIST

| NO | SKETCH | HARDWARE | QTY |
|----|---|----------------|--------|
| 1 |  | JCBC M6 x 30mm | 10 pcs |
| 2 |  | Allen Key | 1 pc |

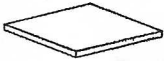
PART LIST

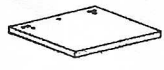
| NO | DESCRIPTION | SKETCH | QTY |
|----|--------------|---|------|
| A | Top Panel |  | 1 pc |
| B | Center Panel |  | 1 pc |
| C | Bottom Panel |  | 1 pc |

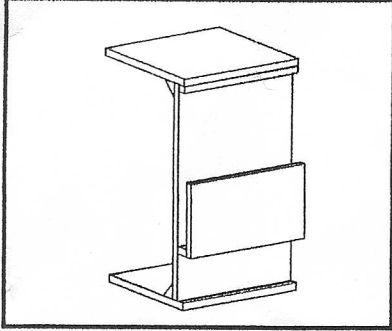

ASSEMBLY STEP

STEP 1

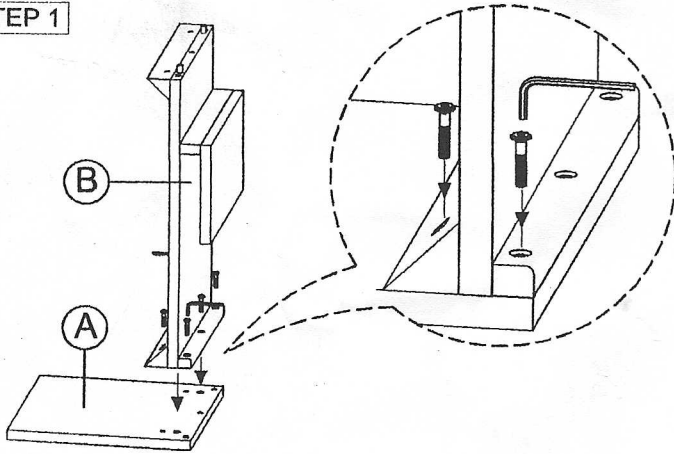

STEP 2

