

PARTS LIST / LISTE DES PIÈCES / LISTA DE PIEZA
 ITEM / NO D'ARTICLE / ARTICULO.: S958-131A / 131B
 DESCRIPTION / DESCRIPCION : Round Dining Table / Table à manger ronde / Mesa de comedor redonda
 Bass Frame / Cadre basse / Marco de bajo

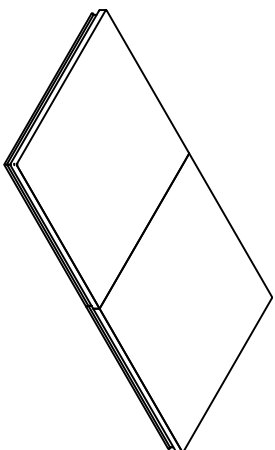

- (A)**
 x1 Table Top
 x1 Dessus de la table
 x1 Mesa

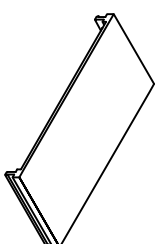

- (B)**
 x1 Table leaf
 x1 Feuille de table
 x1 Hoja de mesa

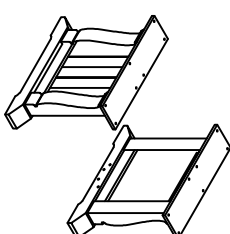

- (C)**
 x2 Table Legs
 x2 Patis de mesa
 x2 Pies de table

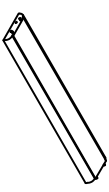

- (D)**
 x1 Bottom Rail
 x1 Traverse inférieure
 x1 Travesaño inferior

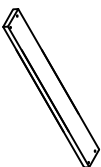

- (E)**
 x1 Stretcher Rail
 x1 Rail de civière
 x1 Camilla de riel



- (1)**
 x14 Allen bolt Ø5/16 * 38mm
 x14 Vis à tête creuse hexagonale Ø5/16 * 38mm
 x14 Perno Allen Ø5/16 * 38mm



- (2)**
 x4 Allen bolt Ø5/16 * 55mm
 x4 Vis à tête creuse hexagonale Ø5/16 * 55mm
 x4 Perno Allen Ø5/16 * 55mm



- (3)**
 x18 Lock washer Ø5/16**13*2mm *
 x18 Rondelle de blocage Ø5/16**13*2mm
 x18 Arandela de Seguridad Ø5/16**13*2mm



- (4)**
 x18 Flat washer Ø5/16**19*2mm *
 x18 Rondelle plate Ø5/16**19*2mm
 x18 Arandela plana Ø5/16**19*2mm

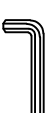

- (5)**
 x1 Allen key M4 *
 x1 Clé hexagonale
 x1 Llave Allen

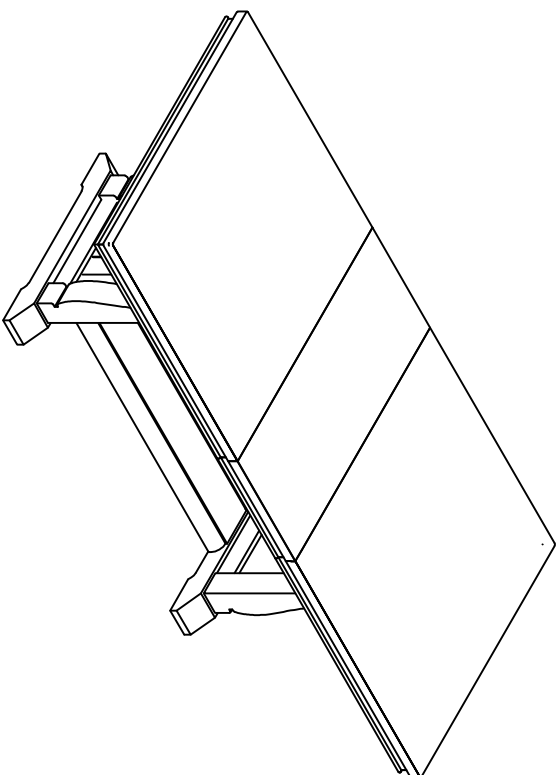

*Replaceable Part

ASSEMBLY INSTRUCTION / NOTICE DE MONTAGE / INSTRUCCIONES DE MONTAJE

ITEM / NO D'ARTICLE / ARTICULO.: S958-131A / 131B

DESCRIPTION / DESCRIPCION : Round Dining Table / Table à manger ronde / Mesa de comedor redonda
Bass Frame / Cadre basse / Marco de bajo

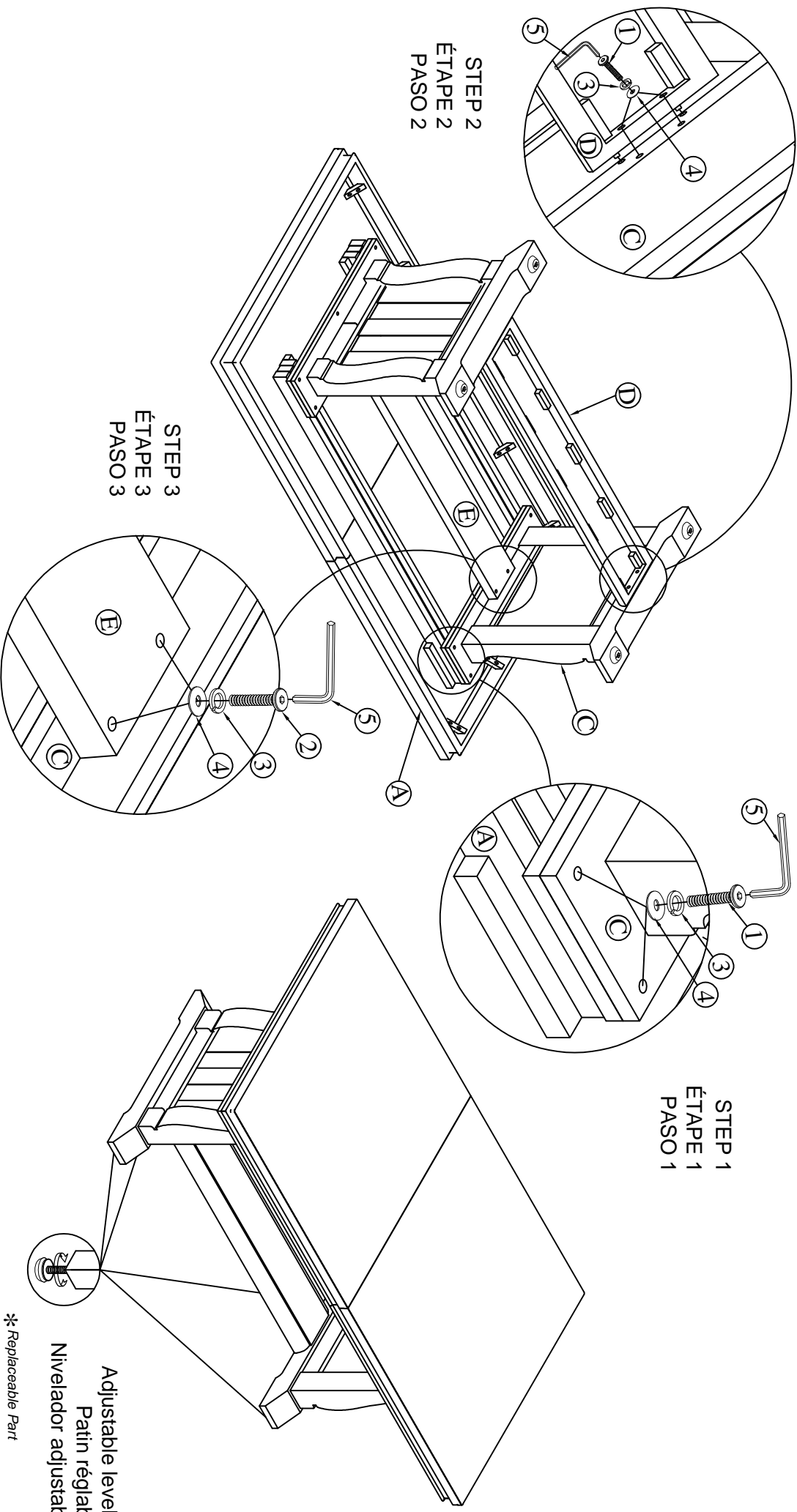

Adjustable leveler
Patin réglable
Nivelador ajustable

*Replaceable Part

ASSEMBLY INSTRUCTION / NOTICE DE MONTAGE / INSTRUCCIONES DE MONTAJE

ITEM / NO D'ARTICLE / ARTICULO.: S958-131A / 131B

DESCRIPTION / DESCRIPCION : Round Dining Table / Table à manger ronde / Mesa de comedor redonda
Bass Frame / Cadre basse / Marco de bajo

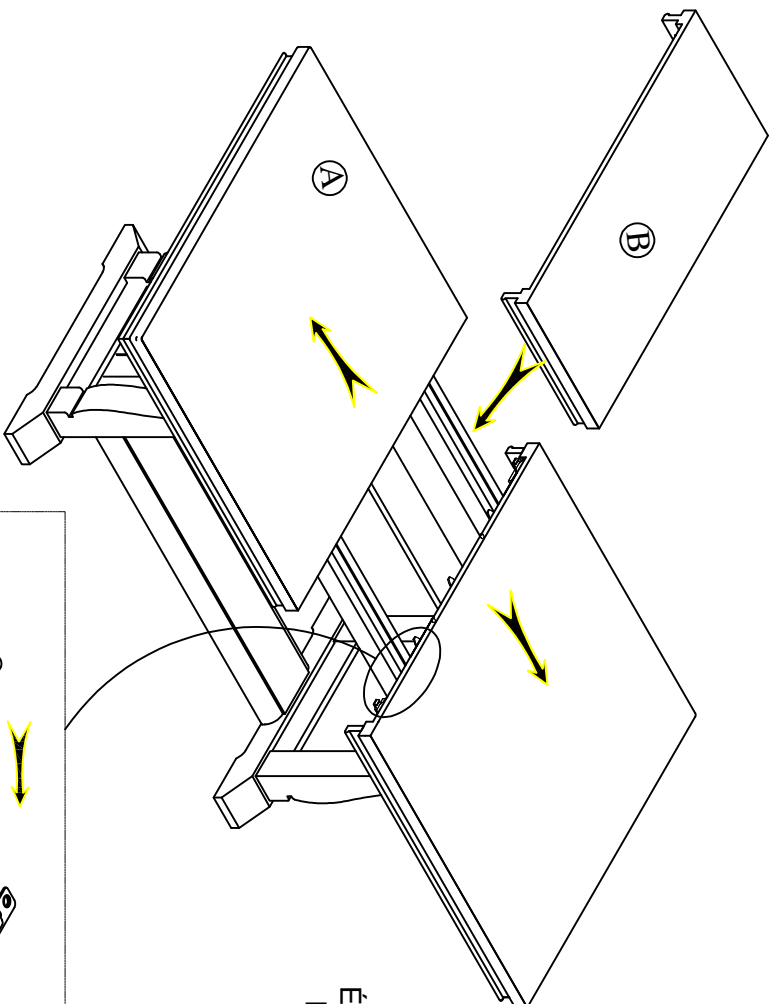

STEP 4
ÉTAPE 4
PASO 4

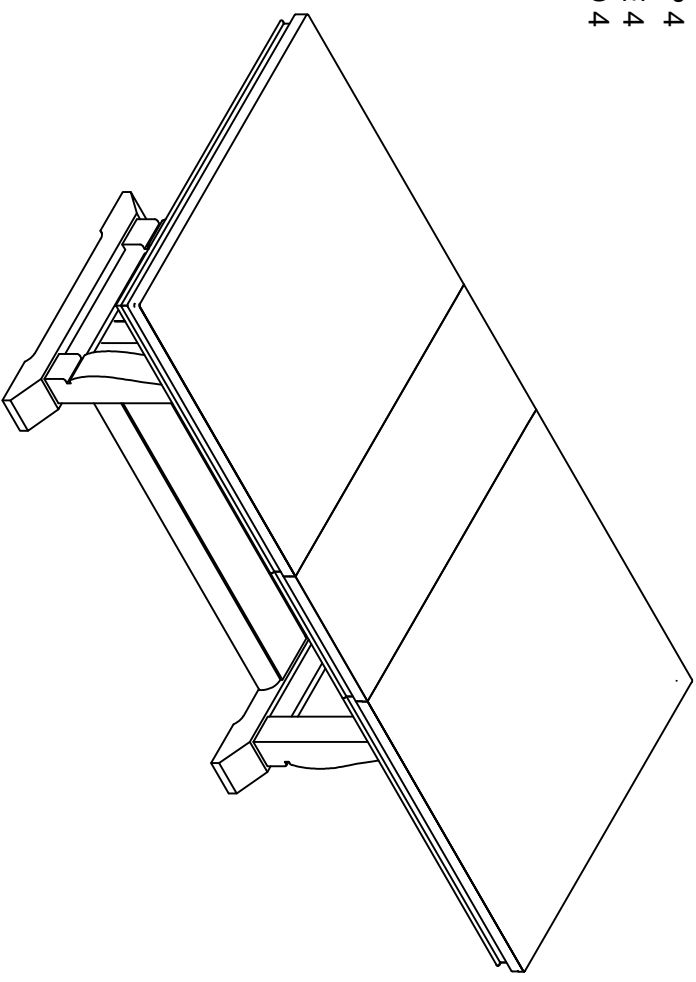
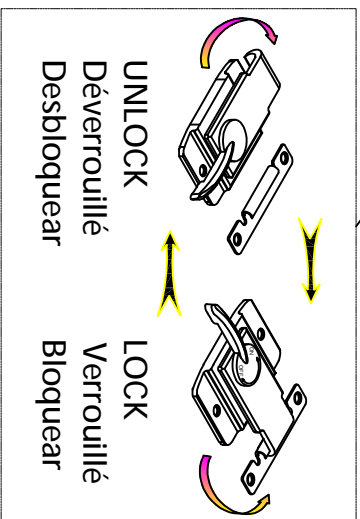

*Replaceable Part

REPLACEABLE PART / PARTIE REMPLACABLE / PARTE REEMPLAZABLE

ITEM / NO D'ARTICLE / ARTICULO.: S958-131A / 131B

DESCRIPTION / DESCRIPCION : Round Dining Table / Table à manger ronde / Mesa de comedor redonda

Bass Frame / Cadre basse / Marco de bajo

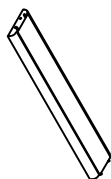

x1 RS958-131-RAL-Bottom Rail *
Rail inférieur
Riel inferior

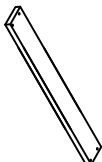

x1 RS958-131-RAL-Top Rail *
Rail supérieur
Riel superior



x1 RS958-131-HWKIT-Hardware kit list *
Liste des pièces de quincailleries
Lista del kit de materiales

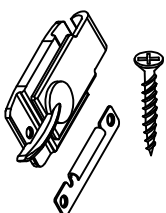

x2 RS958-131-LOCK - Table lock *
Serrure de table
Bloqueo de mesa

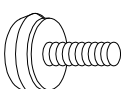

x4 RC-FG-BROWN-Brown leveler *
Niveladora marrón
Niveleur marron

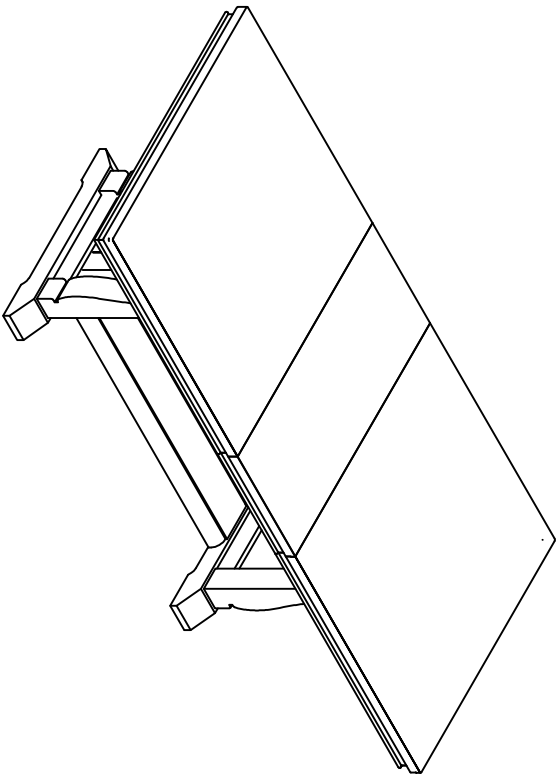

* Replaceable Part

Protect Your Wood or Laminate Flooring

*This statement applies to any floor without carpet.

If not careful, all furniture including upholstery and case pieces can scratch, scuff and even gouge floors. The recommendation is to have felt, rubber pads or area rugs under furniture on flooring without carpet.

Moving your furniture

Pushing and dragging furniture over floors without carpet can lead to scratches and scuffs. Have someone help when moving the larger pieces of furniture by lifting, try using a dolly or moving pads.

Felt and rubber pads

Applying furniture pads to the feet of furniture helps cushion contact points. Furniture pads can be found at local hardware stores. Felt pads slide easily across the floor, making them ideal for dining chairs and other pieces that move with use. Rubber pads will help furniture stay in place and are perfect for larger pieces, like sofas and loveseats.

Area rugs and rug pads

Using an area rug under furniture is another way to protect your floor from scratches and scuff marks. A rug pad under the area rug will provide extra cushion and added protection.