

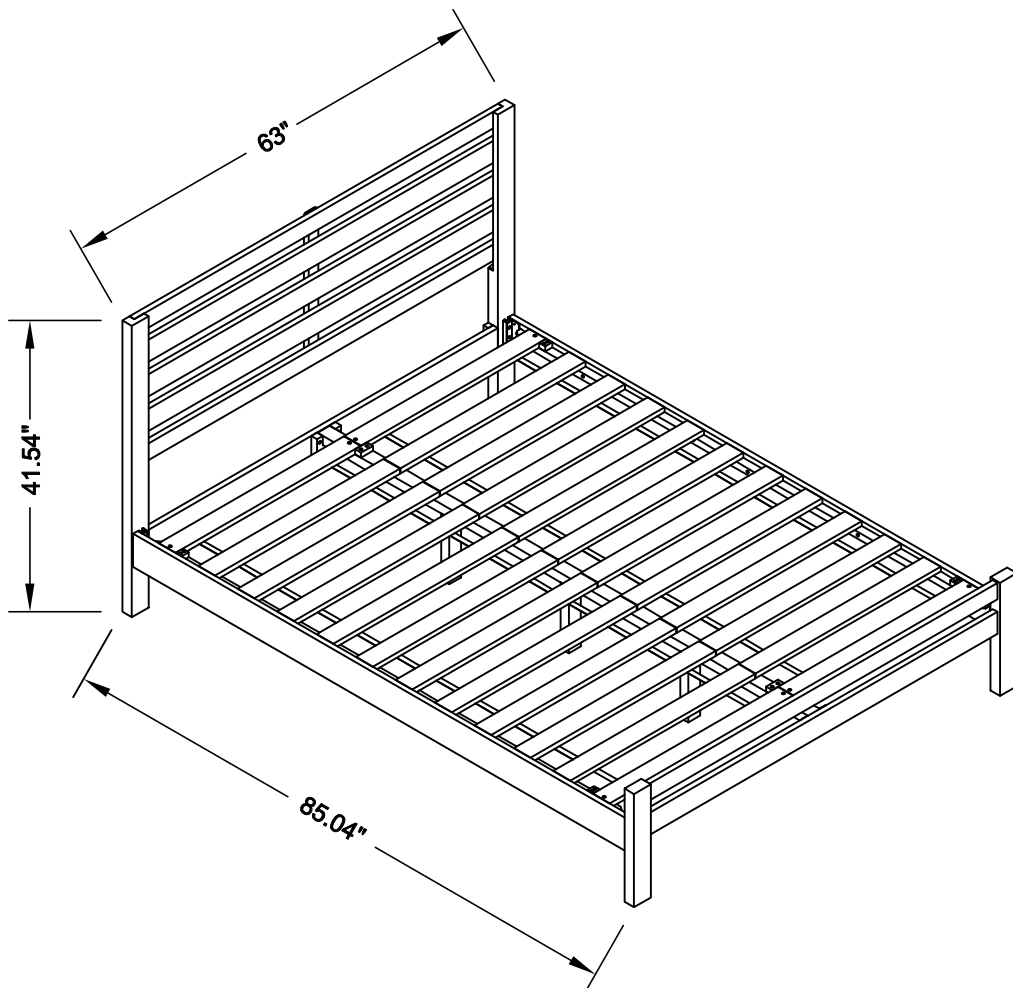











ANDY WOODEN QUEEN BED









ANDY ASSEMBLY INSTRUCTIONS



PARTS LIST

LABLE	PICTURE	DESCRIPTION	QTY.
A		HEADBOARD POST LEFT AND RIGHT	2
B		HEADBOARD HORIZONTAL RAIL (SMALL)	2
C		HEADBOARD HORIZONTAL RAIL (BIG)	3
D		HEADBOARD VERTICAL RAIL	1
E		HEADBOARD BOTTOM RAIL	1
F		SIDERAIL LEFT AND RIGHT	2
G		FOOTBOARD	1
H		SLAT FRAME (12 wood bar)	2
I		MIDDLE RAIL	1
J		CENTER LEG	3

HARDWARES

LABLE	PICTURE	DESCRIPTION	QTY.
K		DOWEL Ø10 x 40mm	4
L		SCREW Ø4 x 30mm	14
M		BOLT Ø1/4" x 12mm	8
N		BOLT Ø1/4" x 30mm	15
O		BOLT Ø1/4" x 40mm	2
P		BOLT Ø1/4" x 50mm	3
Q		WASHER Ø19x1mm	20
R		Allen wrench(4mm)	1
S		Allen wrench(5mm)	1

BEFORE BEGINNING ASSEMBLY :



Read instructions cover to cover



Have two adults on hand for assembly



Do NOT assemble on flooring or carpet. Assemble on a clean non-marring surface (ex: packing foam)



Save all packaging until assembly is completed

ASSEMBLY STEPS

STEPS 1

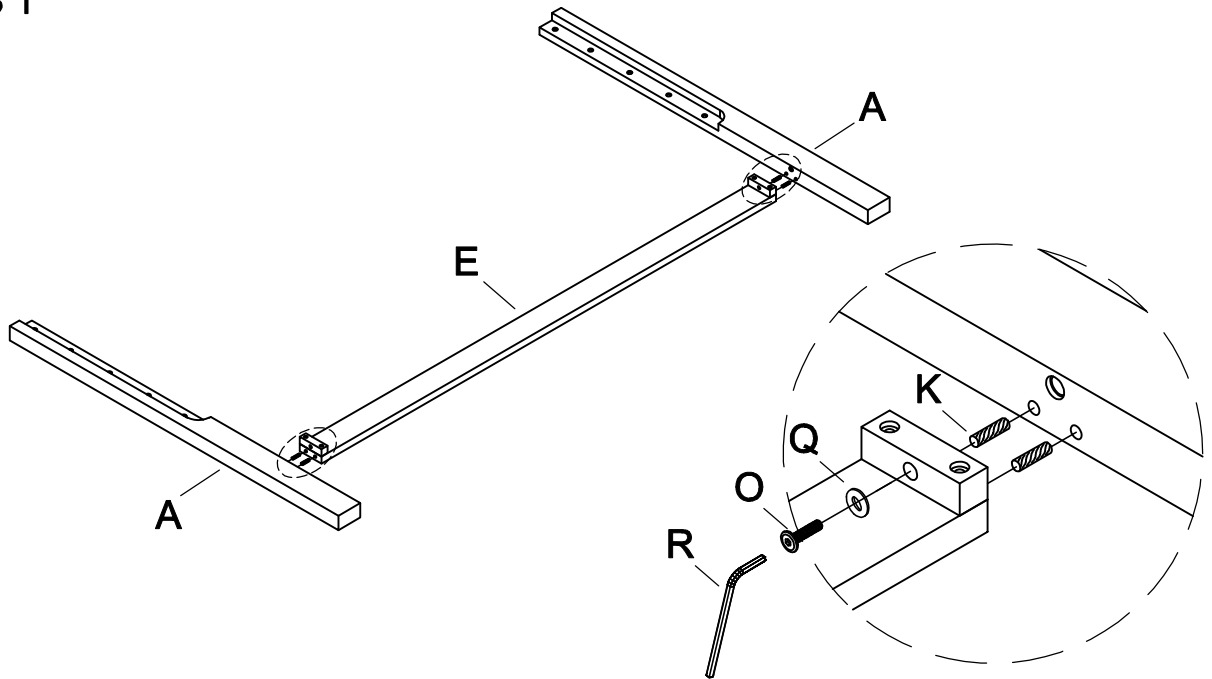

STEPS 2

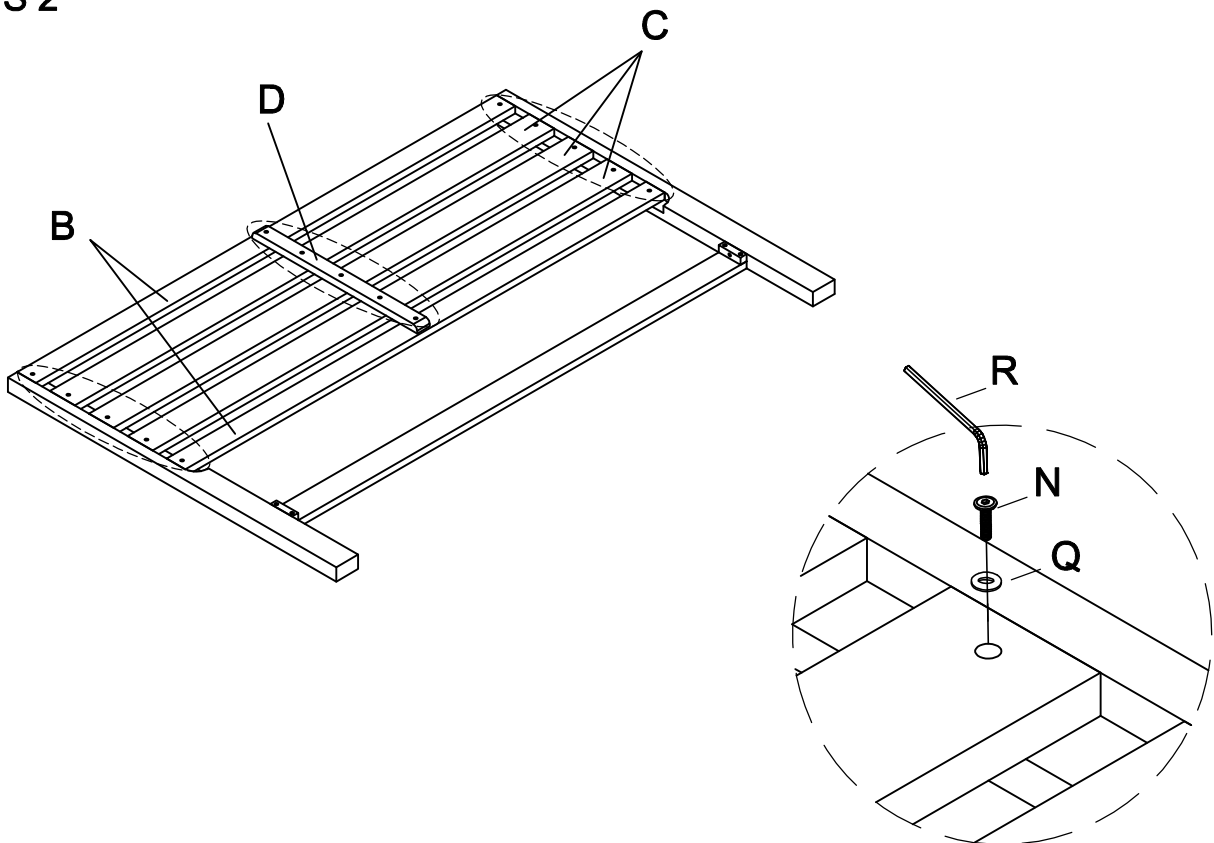

ASSEMBLY STEPS

STEPS 3

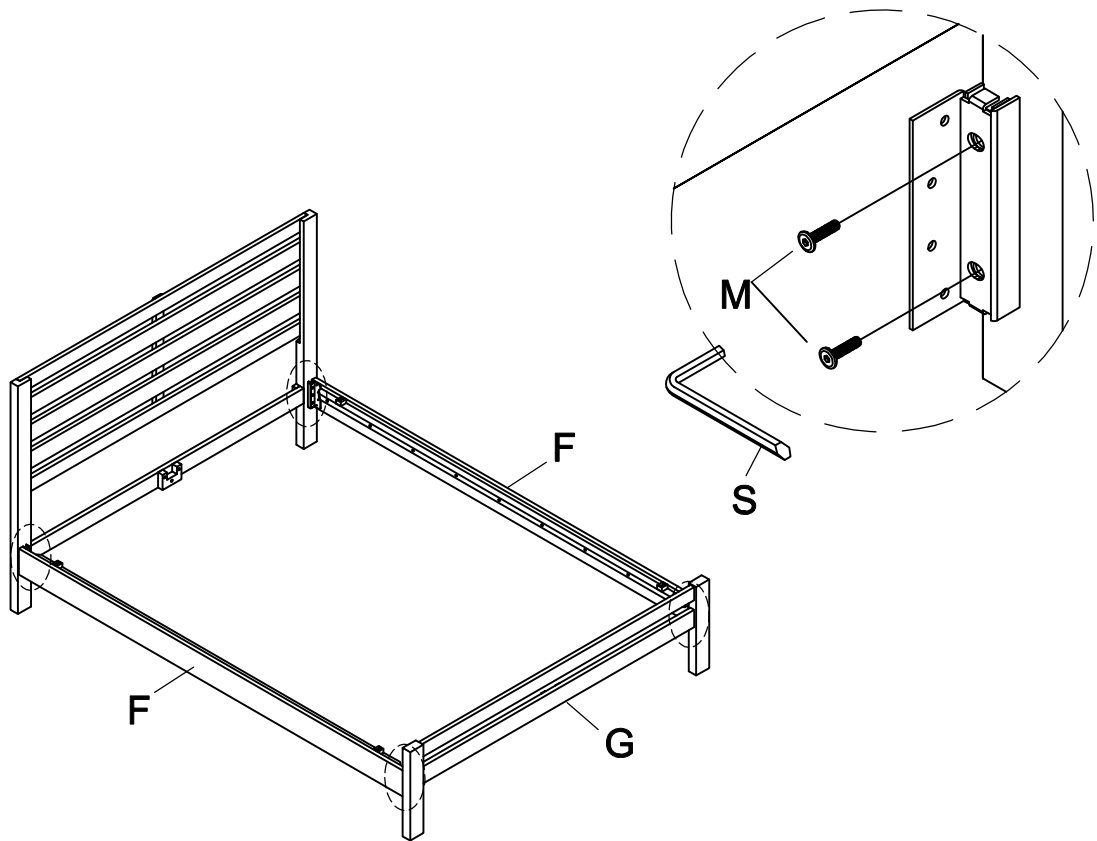

STEPS 4

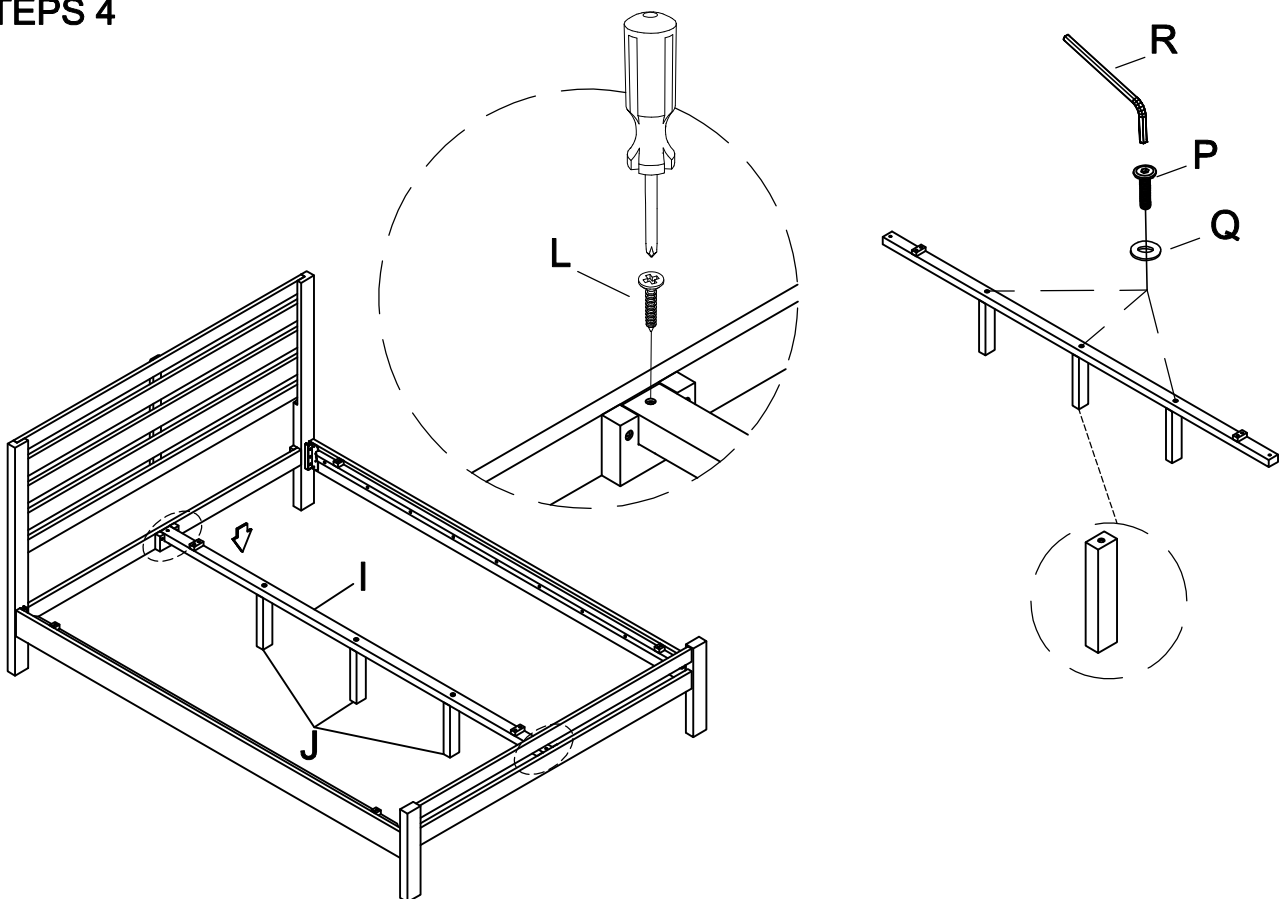

ASSEMBLY STEPS

STEPS 5

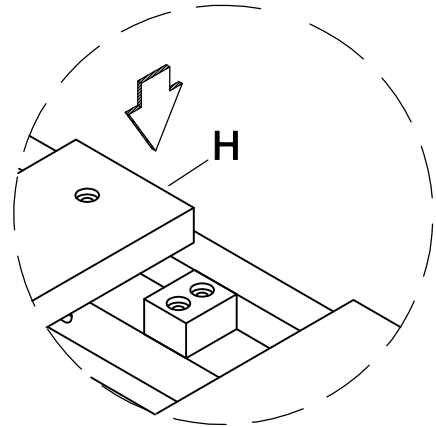
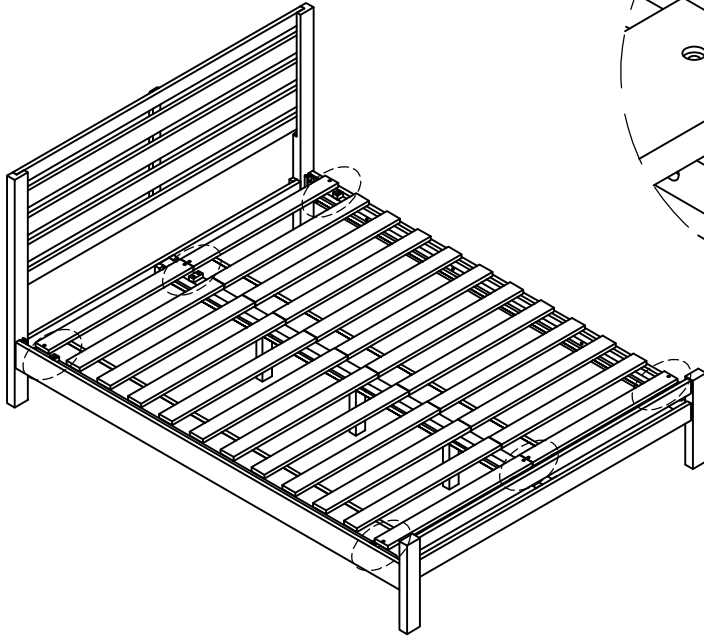

STEPS 6

