

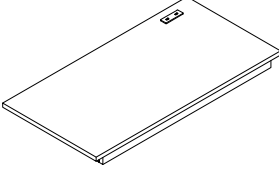
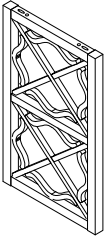
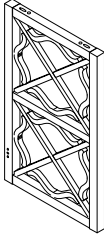
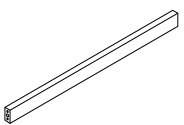
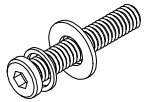

**ASSEMBLY INSTRUCTIONS**  
**ITEM # : 30116-40**  
**EMMA NESTING CONSOLE TABLE**

## NESTING CONSOLE PARTS & HARDWARE LIST

Please assemble with the tool provided or recommended. Do not use an impact drill.

 <p>(A) TABLE TOP x 1</p>	 <p>(B) LSF SIDE FRAME x 1</p>	 <p>(C) RSF SIDE FRAME x 1</p>
 <p>(D) BACK SUPPORT x 1</p>		
 <p>(H2) ALLEN BOLT(Ø5/16" *45MM) x 12 SPRING WASHER(5/16") x 12 FLAT WASHER(5/16") x 12</p>	 <p>(H4) DOWEL x 4 (Ø8*30mm)</p>	 <p>(H5) ALLEN KEY x 1 (M4)</p>

### Customer Service Contact Information:

Toll Free Phone Number: 1-844-771-2727

Email: [consumercare@lanefurniture.com](mailto:consumercare@lanefurniture.com)

Website: [www.lanefurniture.com](http://www.lanefurniture.com)



### NOTES :

- CHECK CAREFULLY FOR SMALL PARTS WHICH MAY COME LOOSE DURING SHIPMENT.
- REMOVE ALL COMPONENTS FROM THE PACK AND PLACE ON A CLEAN, SOFT SURFACE TO ASSEMBLE.
- UNITS SHOULD BE ASSEMBLED BY TWO OR MORE PEOPLE.
- DO NOT OVER - TIGHTEN SCREW/ BOLTS UNTIL ASSEMBLY IS COMPLETED.
- WITH USE, SCREW/ BOLT MAY BE COME LOOSE & MUST BE TIGHTENED PERIODICALLY.

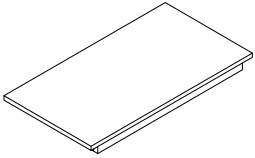
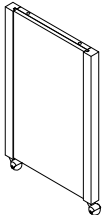
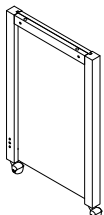
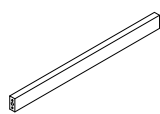
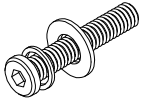
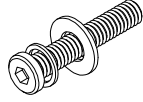

## ROLLING CONSOLE PARTS & HARDWARE LIST

Please assemble with the tool provided or recommended. Do not use an impact drill.

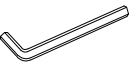
 <p>(E) TABLE TOP x 1</p>	 <p>(F) LSF SIDE FRAME x 1</p>	 <p>(G) RSF SIDE FRAME x 1</p>
 <p>(H) BACK SUPPORT x 1</p>		
 <p>(H1) ALLEN BOLT(Ø5/16" *51 MM) x 4 SPRING WASHER(5/16") x 4 FLAT WASHER(5/16") x 4</p>	 <p>(H3) ALLEN BOLT(Ø5/16" *38 MM) x 6 SPRING WASHER(5/16") x 6 FLAT WASHER(5/16") x 6</p>	 <p>(H4) DOWEL x 4 (Ø8*30mm)</p>
 <p>(H5) ALLEN KEY x 1 (M4)</p>		

### Customer Service Contact Information:

Toll Free Phone Number: 1-844-771-2727

Email: [consumercare@lanefurniture.com](mailto:consumercare@lanefurniture.com)

Website: [www.lanefurniture.com](http://www.lanefurniture.com)



### NOTES :

- CHECK CAREFULLY FOR SMALL PARTS WHICH MAY COME LOOSE DURING SHIPMENT.
- REMOVE ALL COMPONENTS FROM THE PACK AND PLACE ON A CLEAN, SOFT SURFACE TO ASSEMBLE.
- UNITS SHOULD BE ASSEMBLED BY TWO OR MORE PEOPLE.
- DO NOT OVER - TIGHTEN SCREW/ BOLTS UNTIL ASSEMBLY IS COMPLETED.
- WITH USE, SCREW/ BOLT MAY BE COME LOOSE & MUST BE TIGHTENED PERIODICALLY.

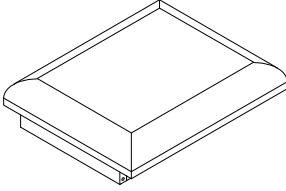
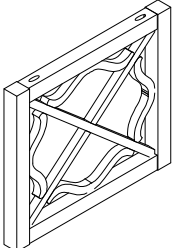
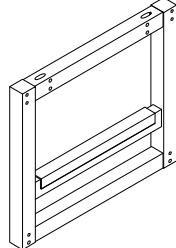
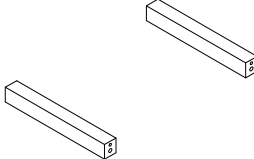
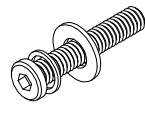

## STOOL PARTS & HARDWARE LIST

Please assemble with the tool provided or recommended. Do not use an impact drill.

 <p>① SEAT BOX x 1</p>	 <p>② BACK SIDE FRAME x 1</p>	 <p>③ FRONT SIDE FRAME x 1</p>
 <p>④ SIDE STRETCHER x 2</p>		
 <p>⑤ ALLEN BOLT(Ø5/16" *45 MM) x 12 SPRING WASHER(5/16") x 12 FLAT WASHER(5/16") x 12</p>	 <p>⑥ DOWEL x 12 (Ø8*30mm)</p>	 <p>⑦ ALLEN KEY x 1 (M4)</p>

### Customer Service Contact Information:

Toll Free Phone Number: 1-844-771-2727

Email: [consumercare@lanefurniture.com](mailto:consumercare@lanefurniture.com)

Website: [www.lanefurniture.com](http://www.lanefurniture.com)

### NOTES :

- CHECK CAREFULLY FOR SMALL PARTS WHICH MAY COME LOOSE DURING SHIPMENT.
- REMOVE ALL COMPONENTS FROM THE PACK AND PLACE ON A CLEAN, SOFT SURFACE TO ASSEMBLE.
- UNITS SHOULD BE ASSEMBLED BY TWO OR MORE PEOPLE.
- DO NOT OVER - TIGHTEN SCREW/ BOLTS UNTIL ASSEMBLY IS COMPLETED.
- WITH USE, SCREW/ BOLT MAY BE COME LOOSE & MUST BE TIGHTENED PERIODICALLY.



HARDWARE BLISTER PACKS ARE STORED INSIDE THE NESTING CONSOLE

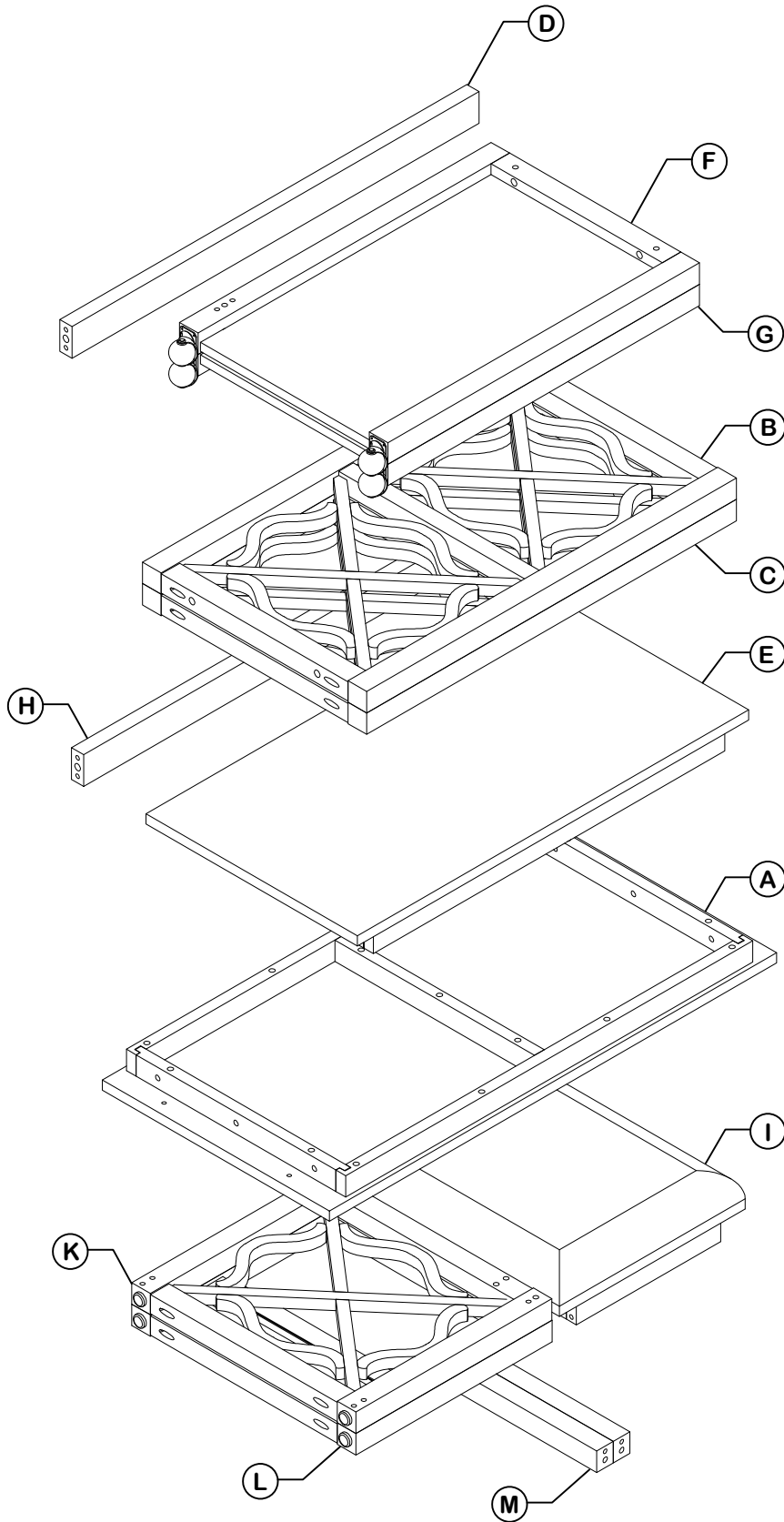

**STEP 1 ( x1)**

**Do not over-tighten the bolts. Make sure you use the lock washers to ensure the bolts stay fastened**

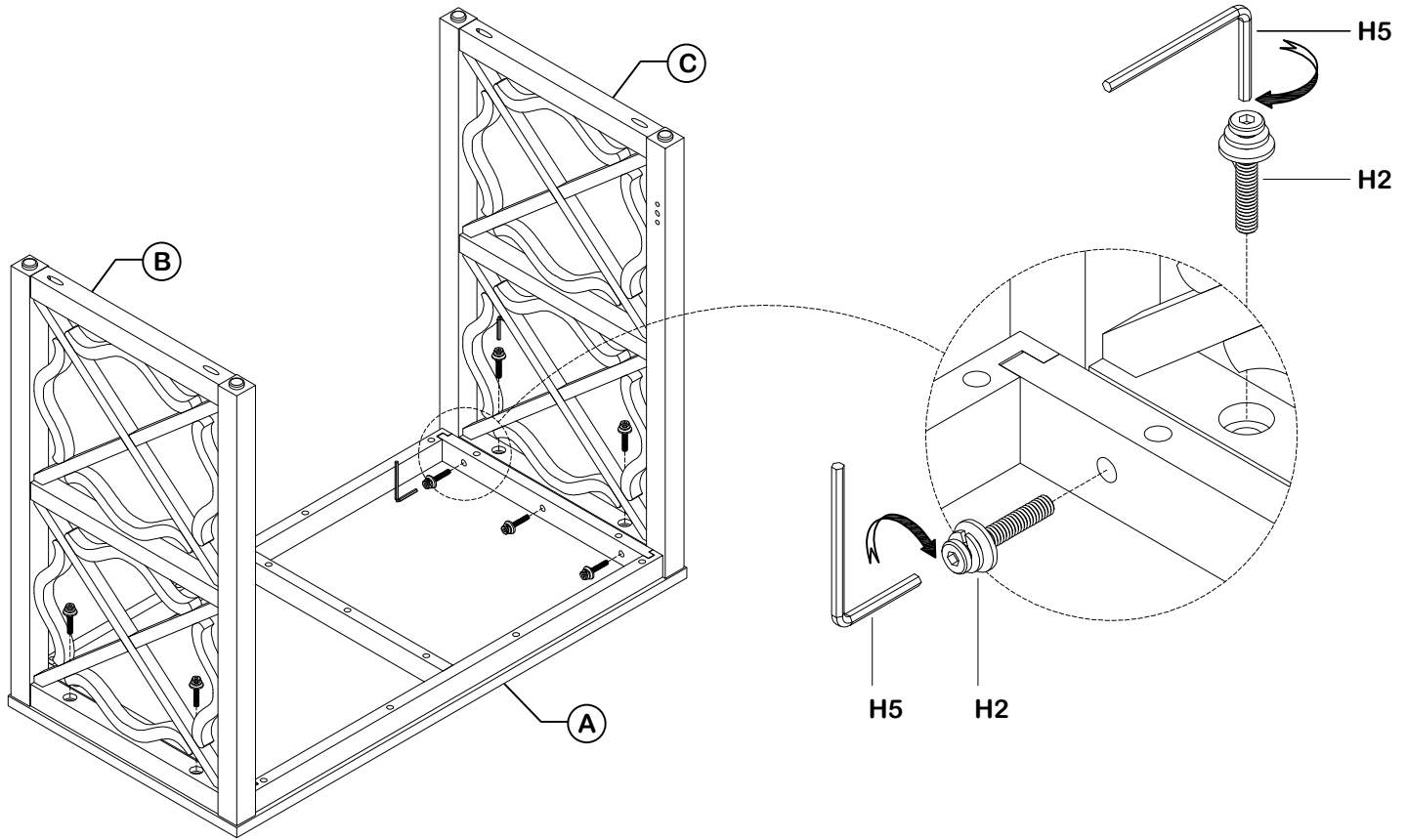

**STEP 2 ( x1)**

**Do not over-tighten the bolts. Make sure you use the lock washers to ensure the bolts stay fastened**

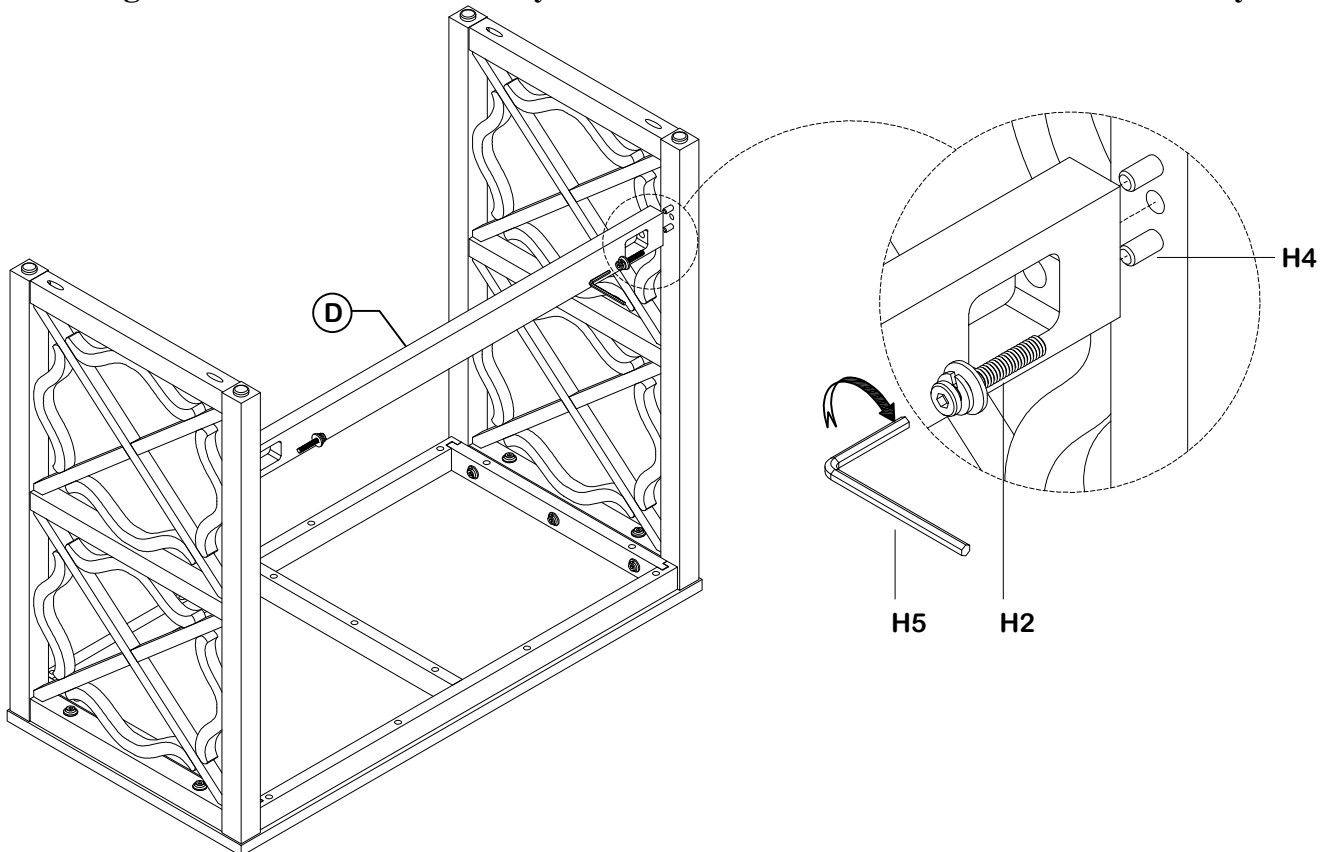

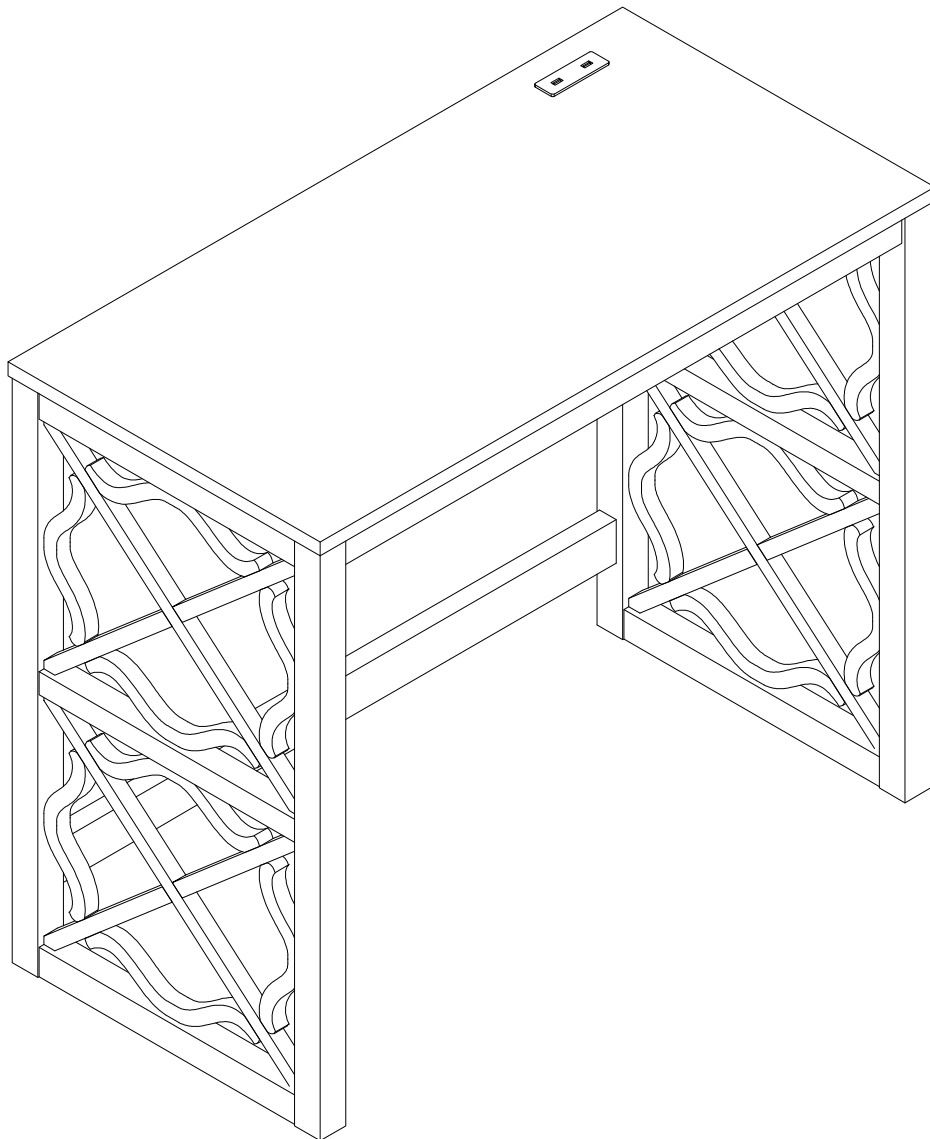

NESTING CONSOLE ASSEMBLY COMPLETED

**STEP 3 ( x1)**

**Do not over-tighten the bolts. Make sure you use the lock washers to ensure the bolts stay fastened**

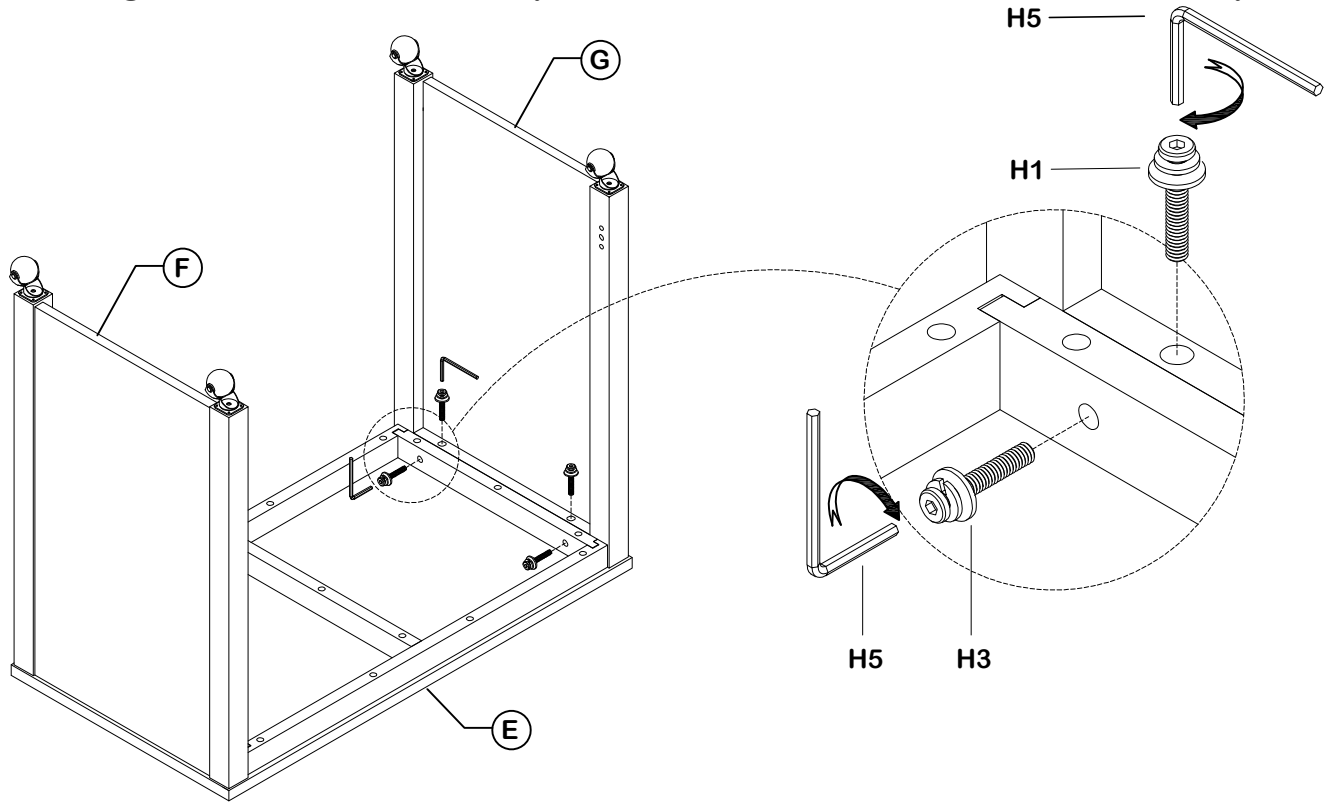

**STEP 4 ( x1)**

**Do not over-tighten the bolts. Make sure you use the lock washers to ensure the bolts stay fastened**

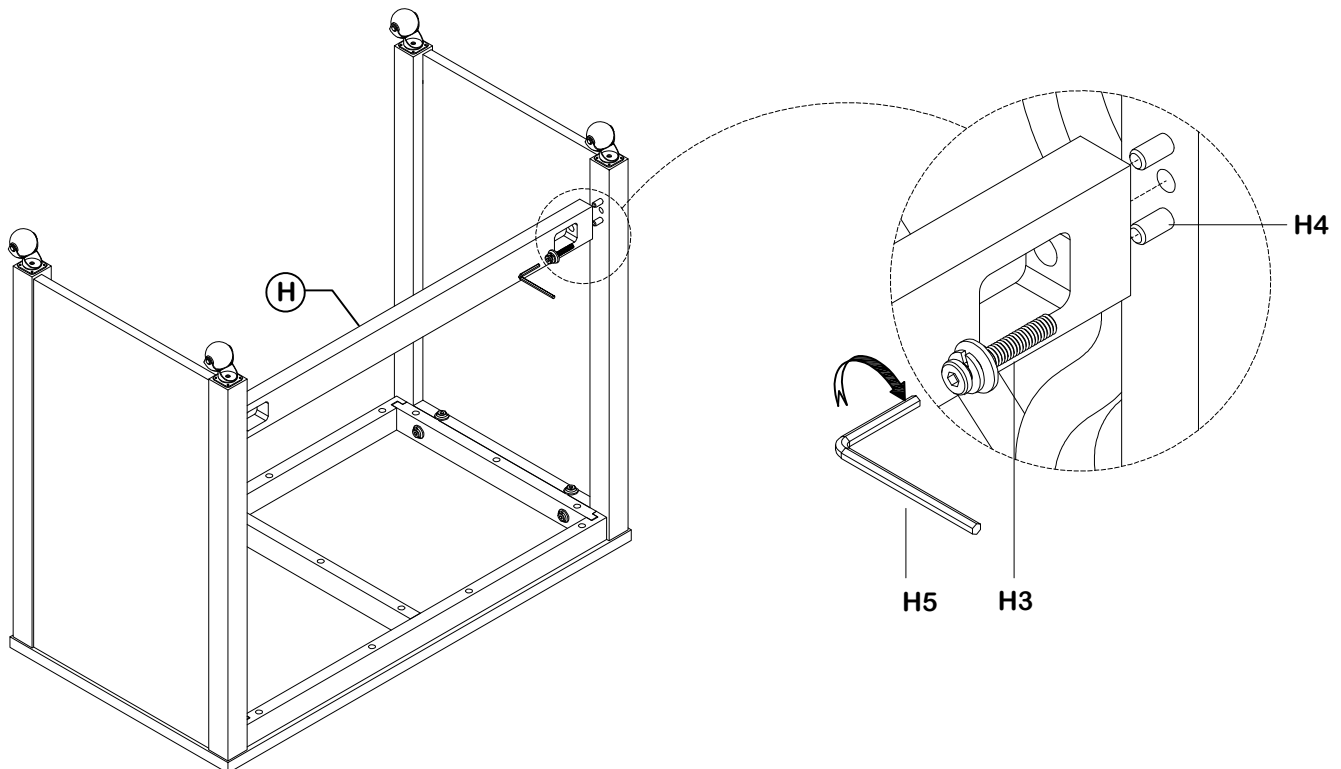



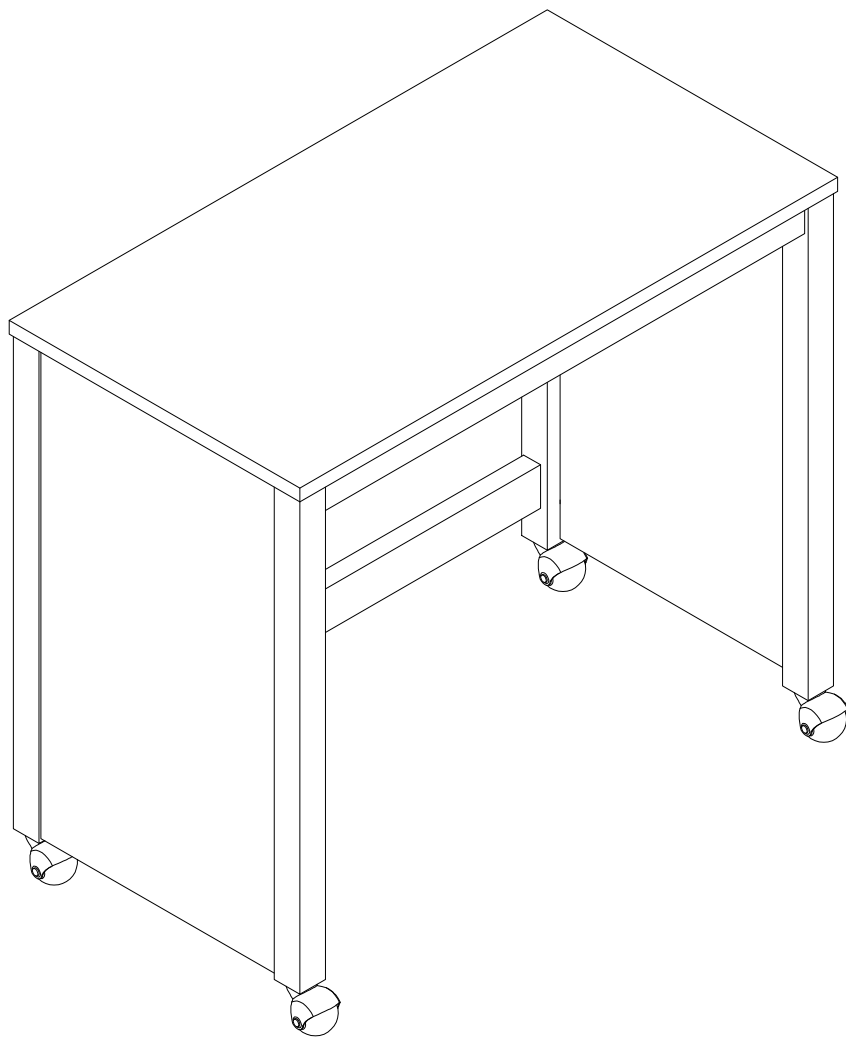

ROLLING CONSOLE ASSEMBLY COMPLETED

**STEP 5 ( x1)**

**Do not over-tighten the bolts. Make sure you use the lock washers to ensure the bolts stay fastened**

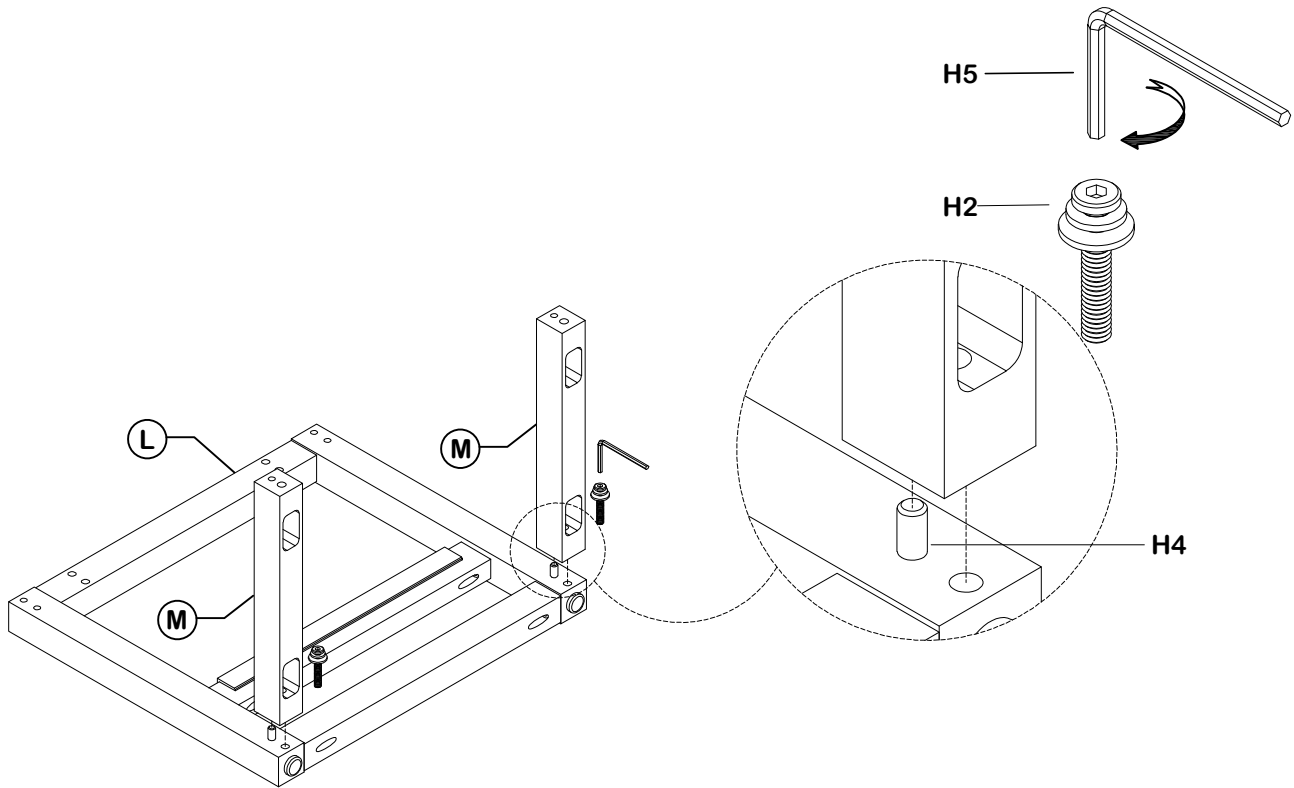

**STEP 6 ( x1)**

**Do not over-tighten the bolts. Make sure you use the lock washers to ensure the bolts stay fastened**

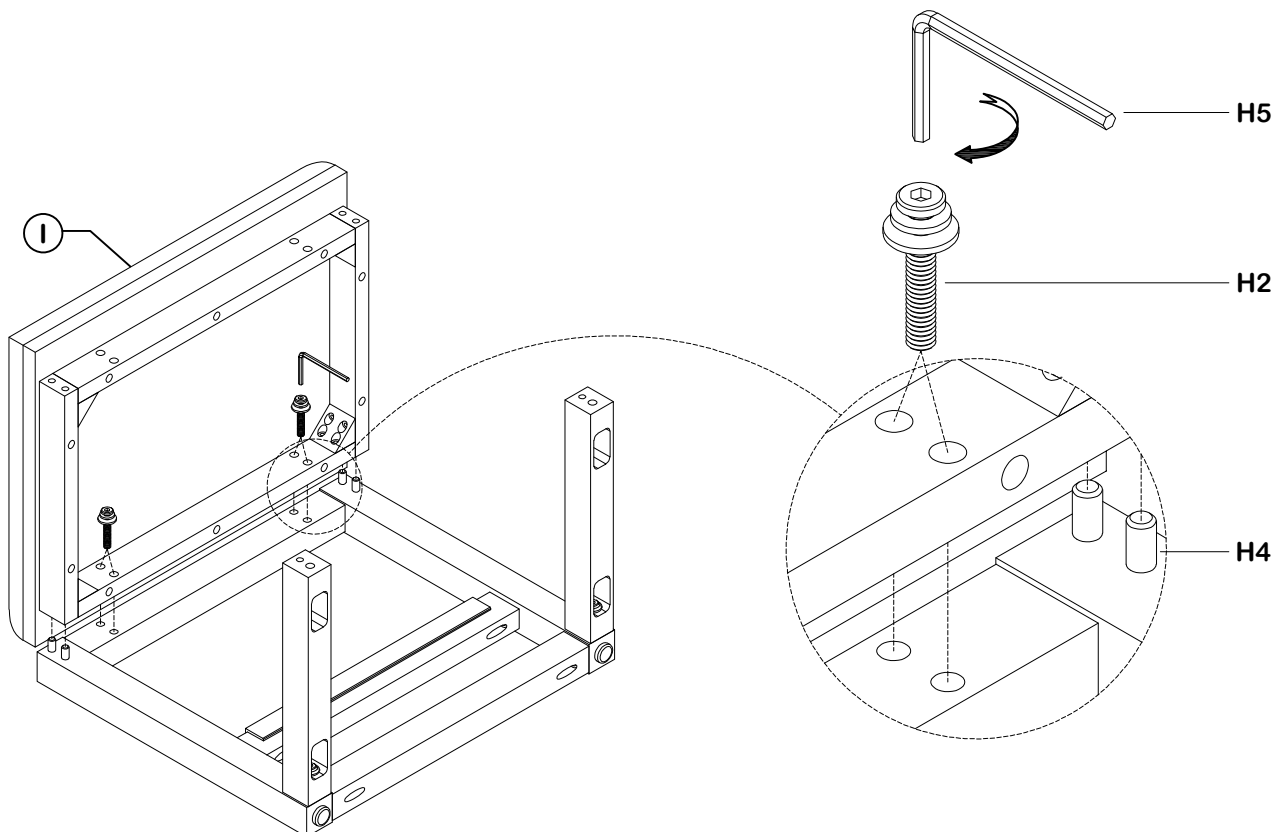

**STEP 7 ( x1)**

**Do not over-tighten the bolts. Make sure you use the lock washers to ensure the bolts stay fastened**

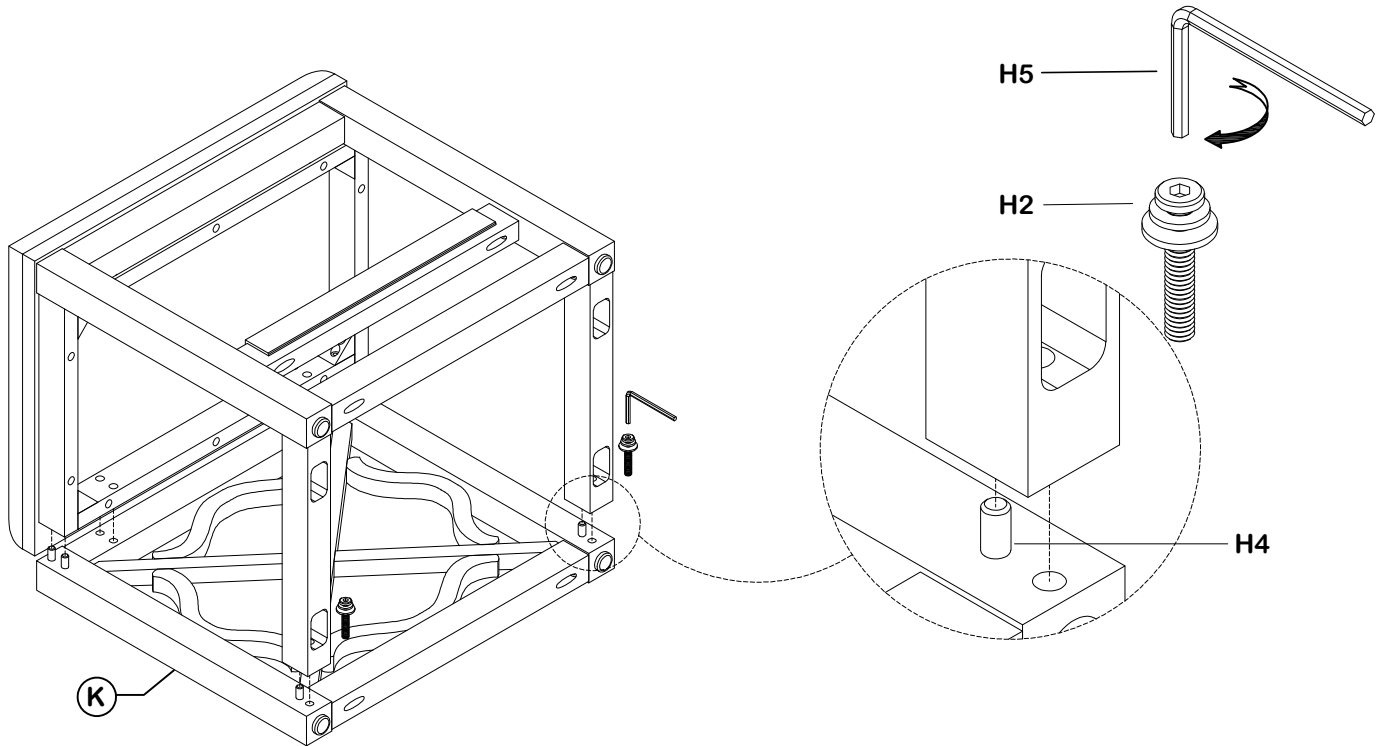

**STEP 8 ( x1)**

**Do not over-tighten the bolts. Make sure you use the lock washers to ensure the bolts stay fastened**

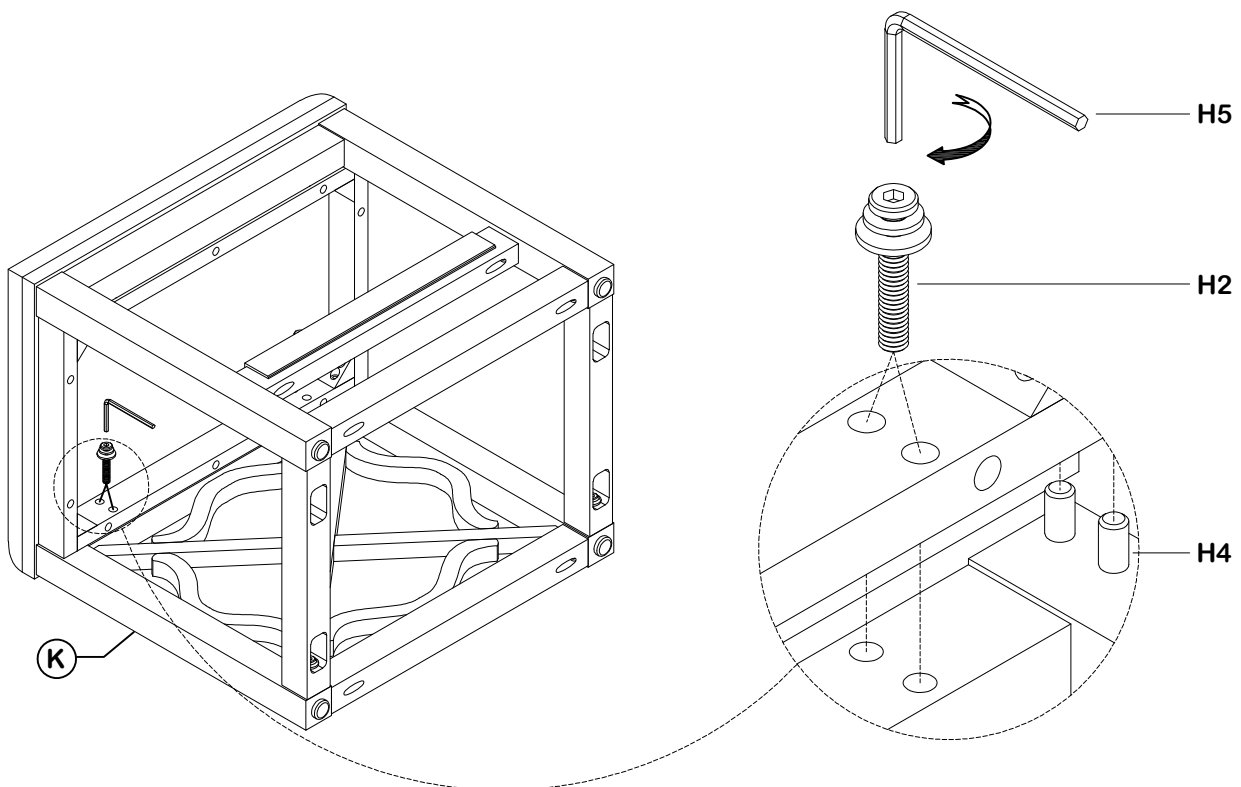

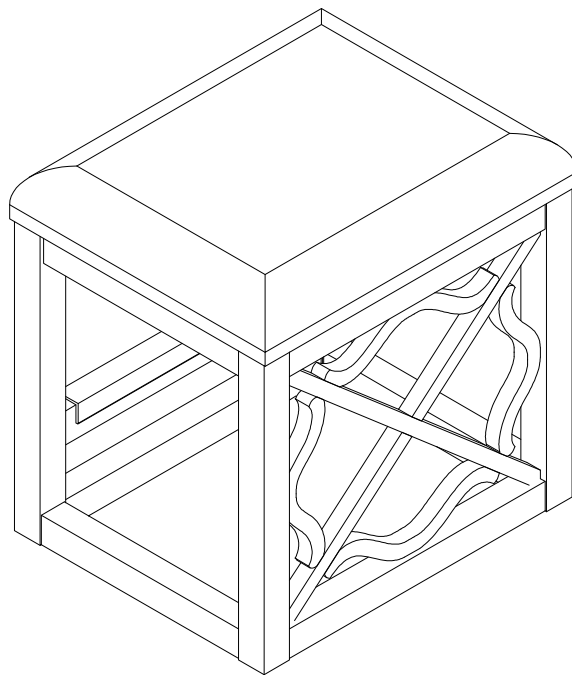

**STOOL ASSEMBLY COMPLETED**