

**BIG GAME DAYBED  
CANAPÉ-LIT GRAND MATCH  
SOFÁ CAMA GRAN PARTIDO**

**# 15Y8174**

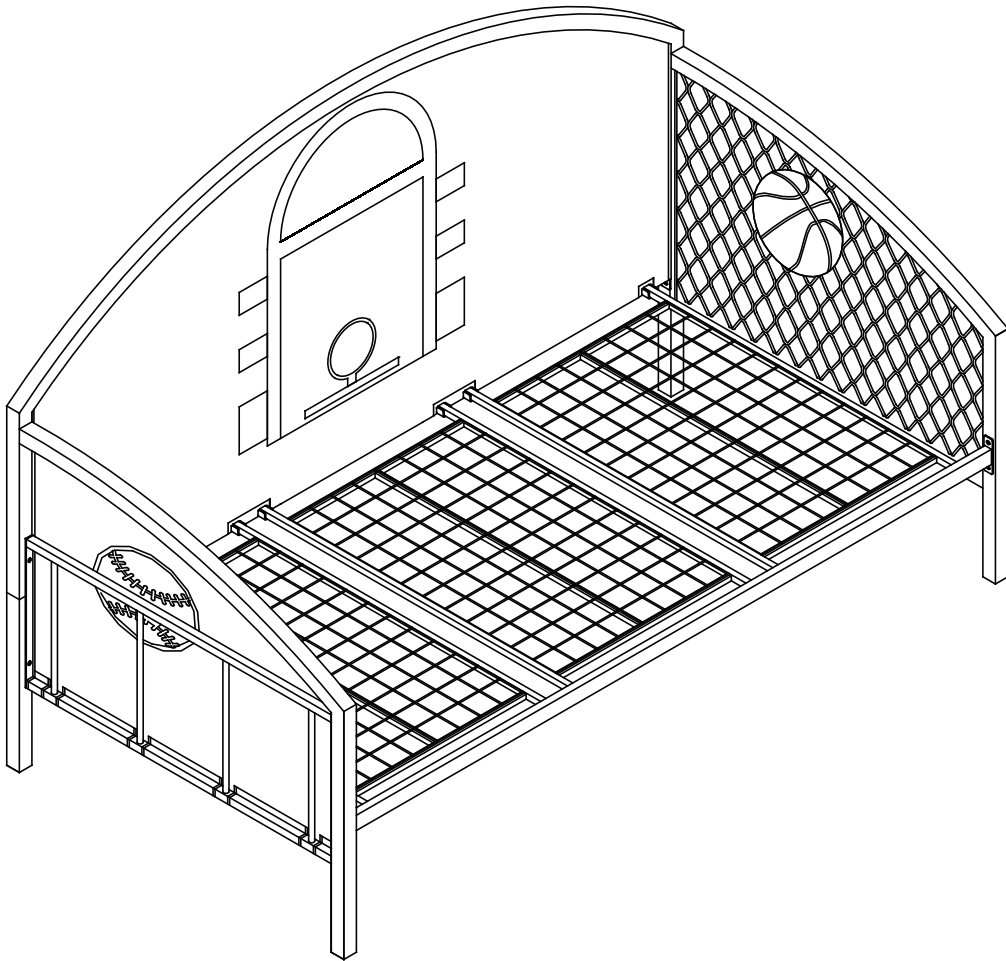

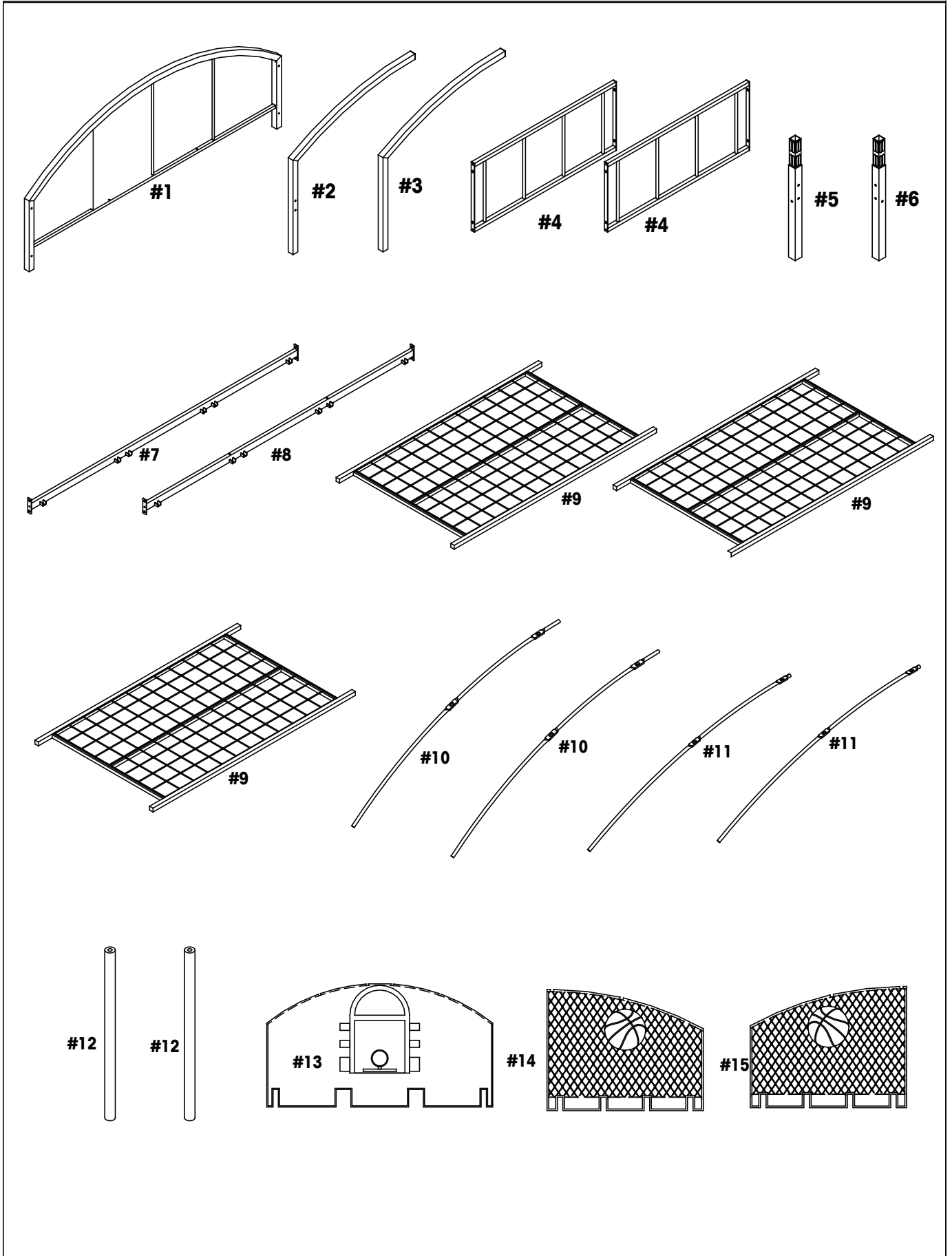

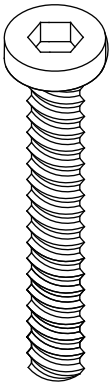

**A x 4**  
( $\Phi$  1/4" x 2-1/4")

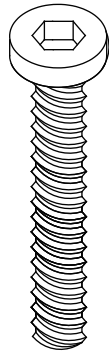

**B x 2**  
( $\Phi$  1/4" x 1-1/2")

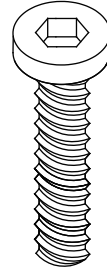

**C x 28**  
( $\Phi$  1/4" x 3/4")

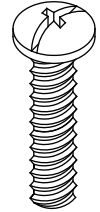

**D x 8**  
( $\Phi$  3/16" x 1/2")

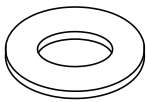

**E x 34**  
( $\Phi$  1/4")

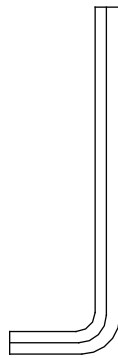

supplied  
fourni  
suministrado



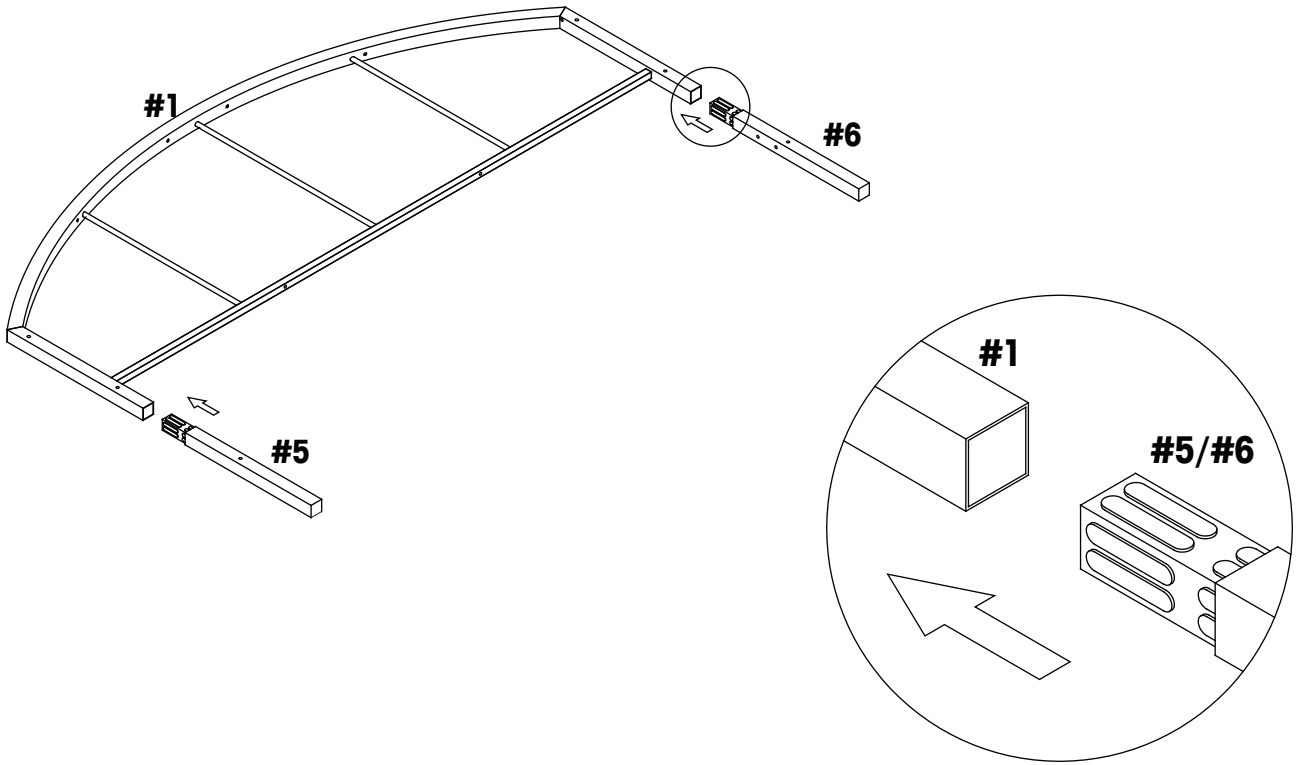

not supplied  
not furni  
not suministrado

1.



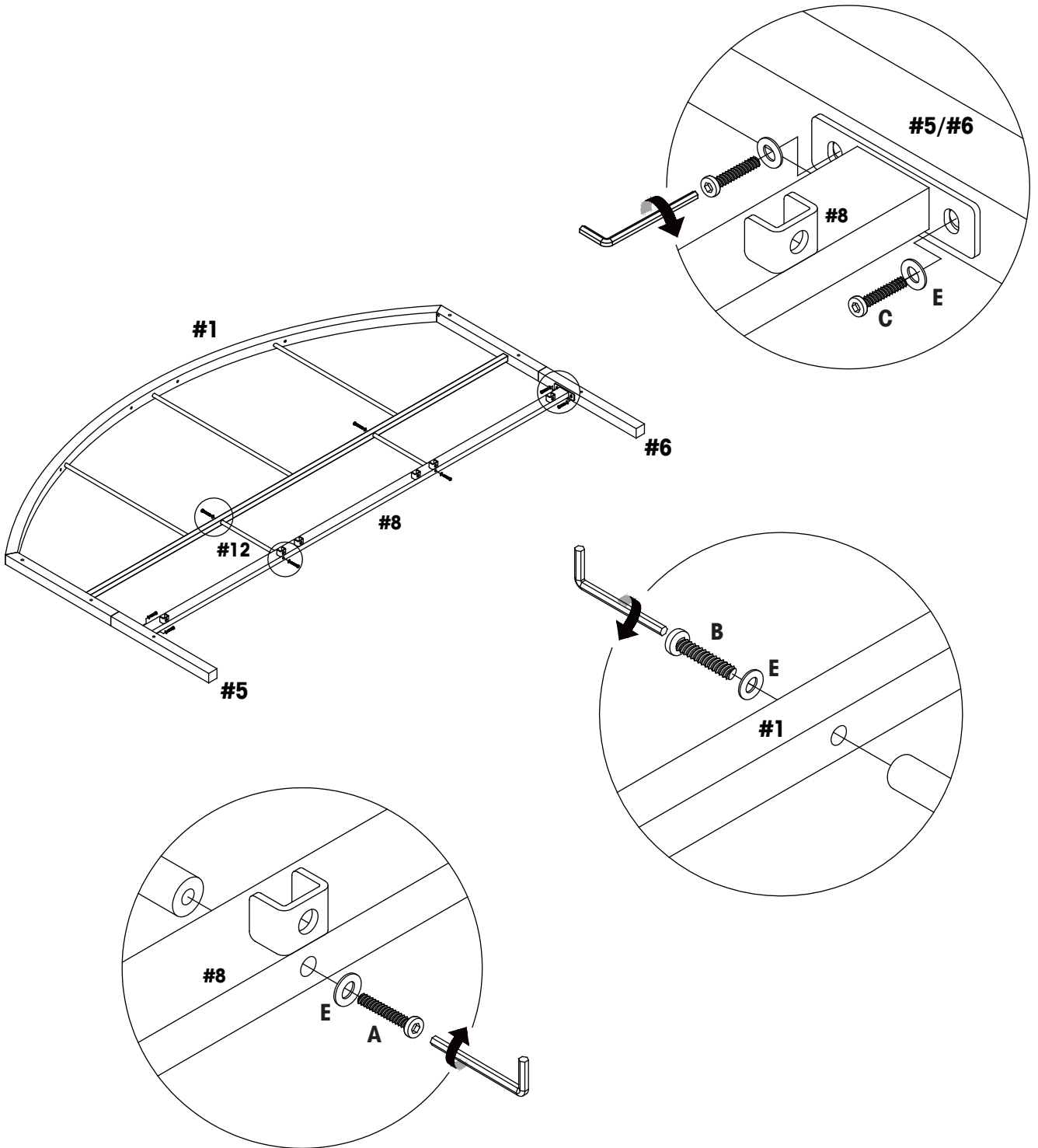

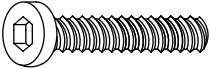
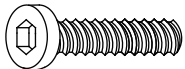
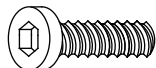
2.



A		02
B		02
C		04
E		08

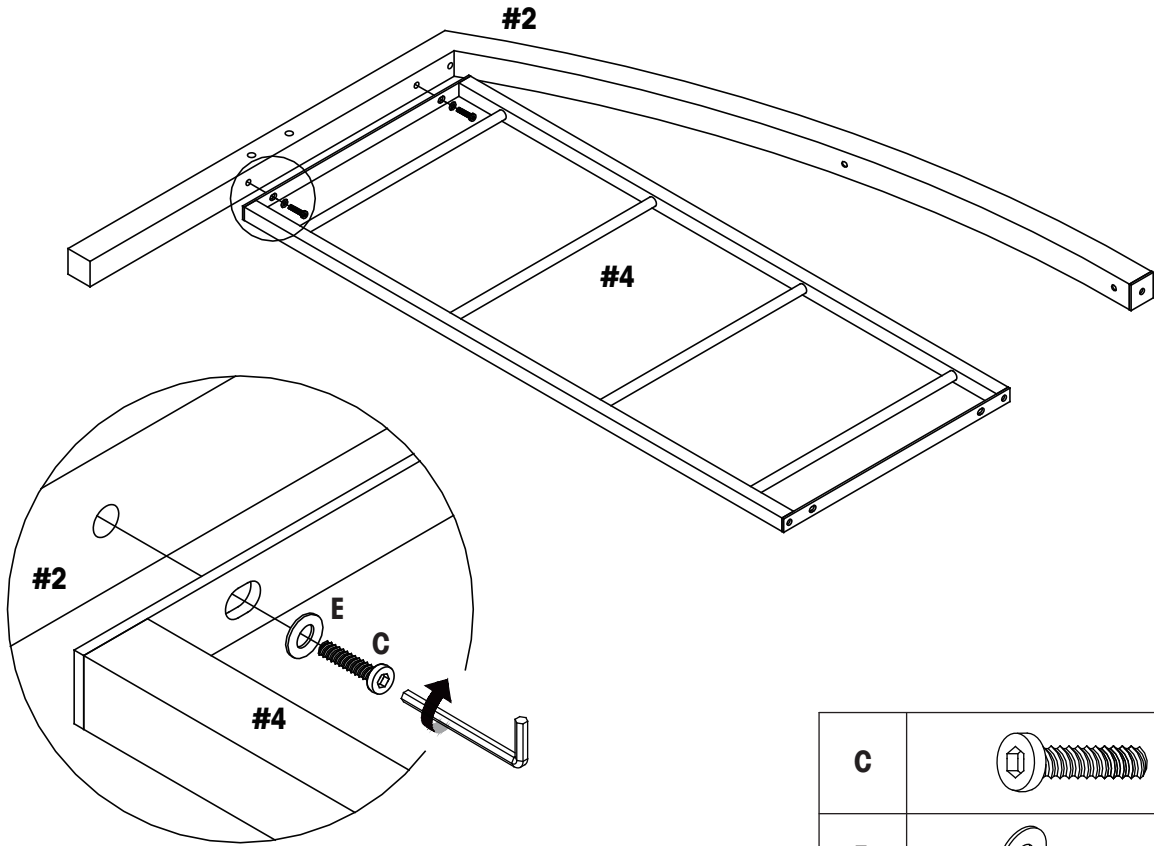

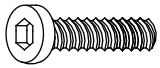
3.



C		02
E		02

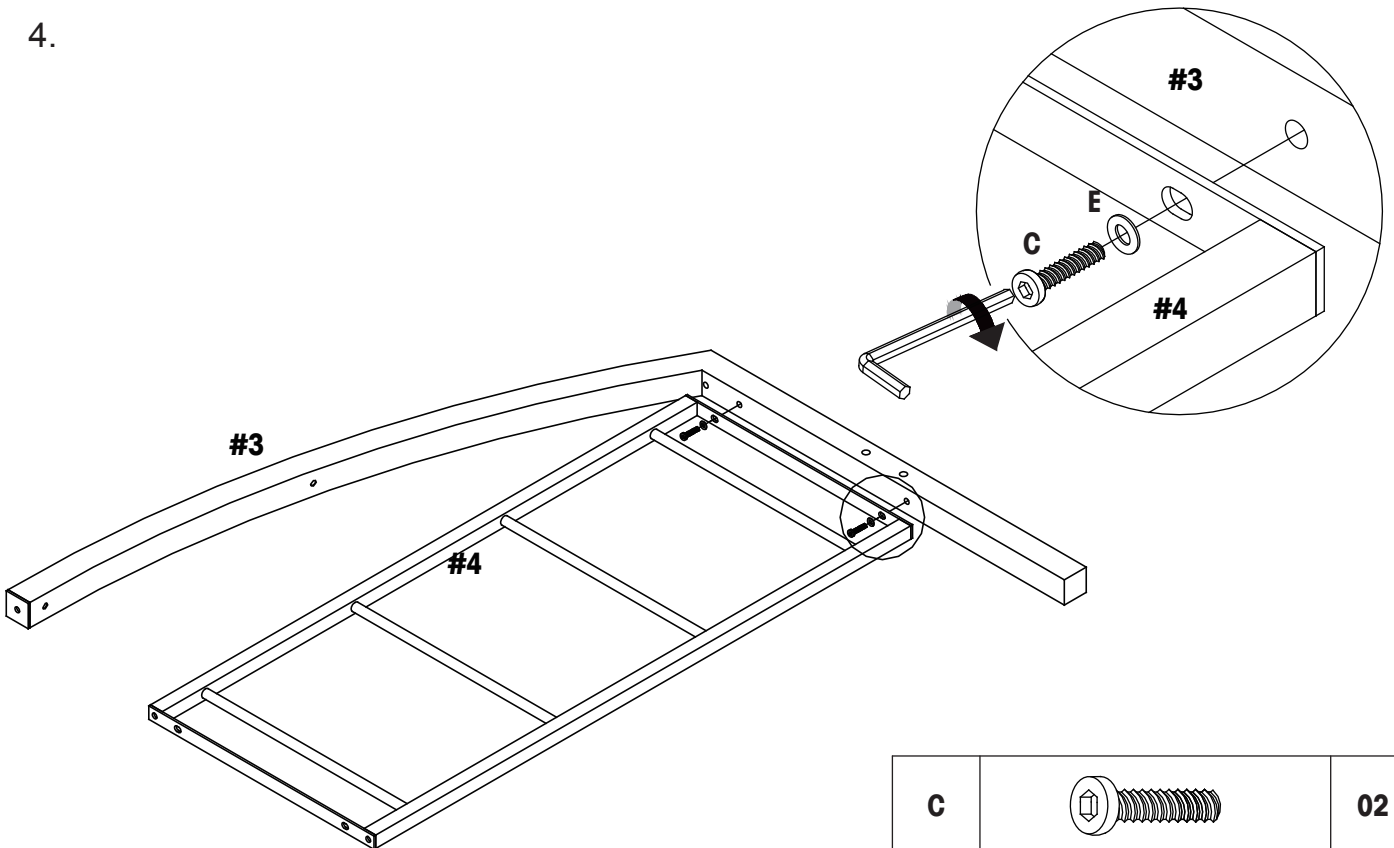

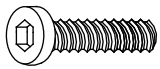
4.



C		02
E		02

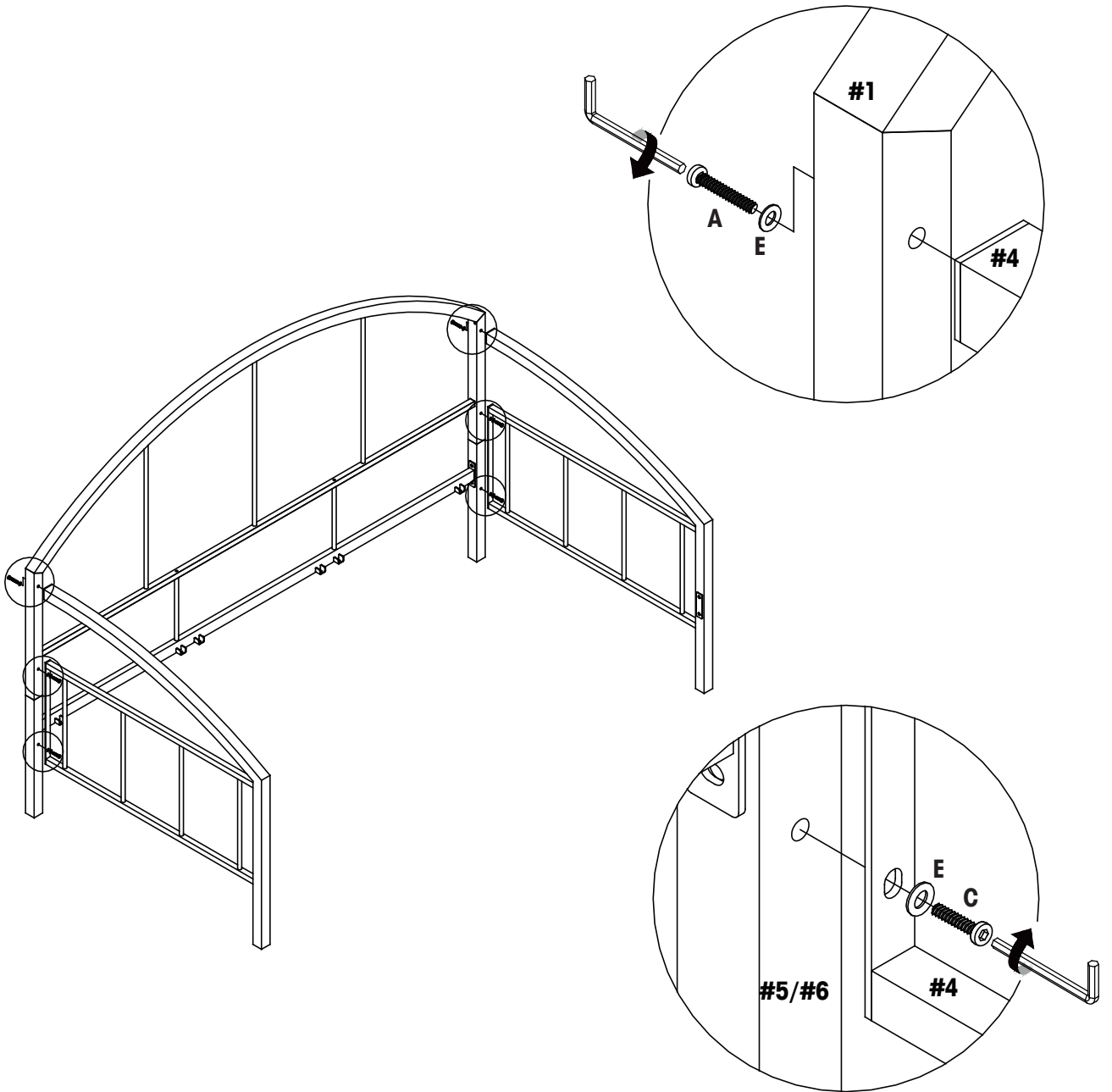

5.

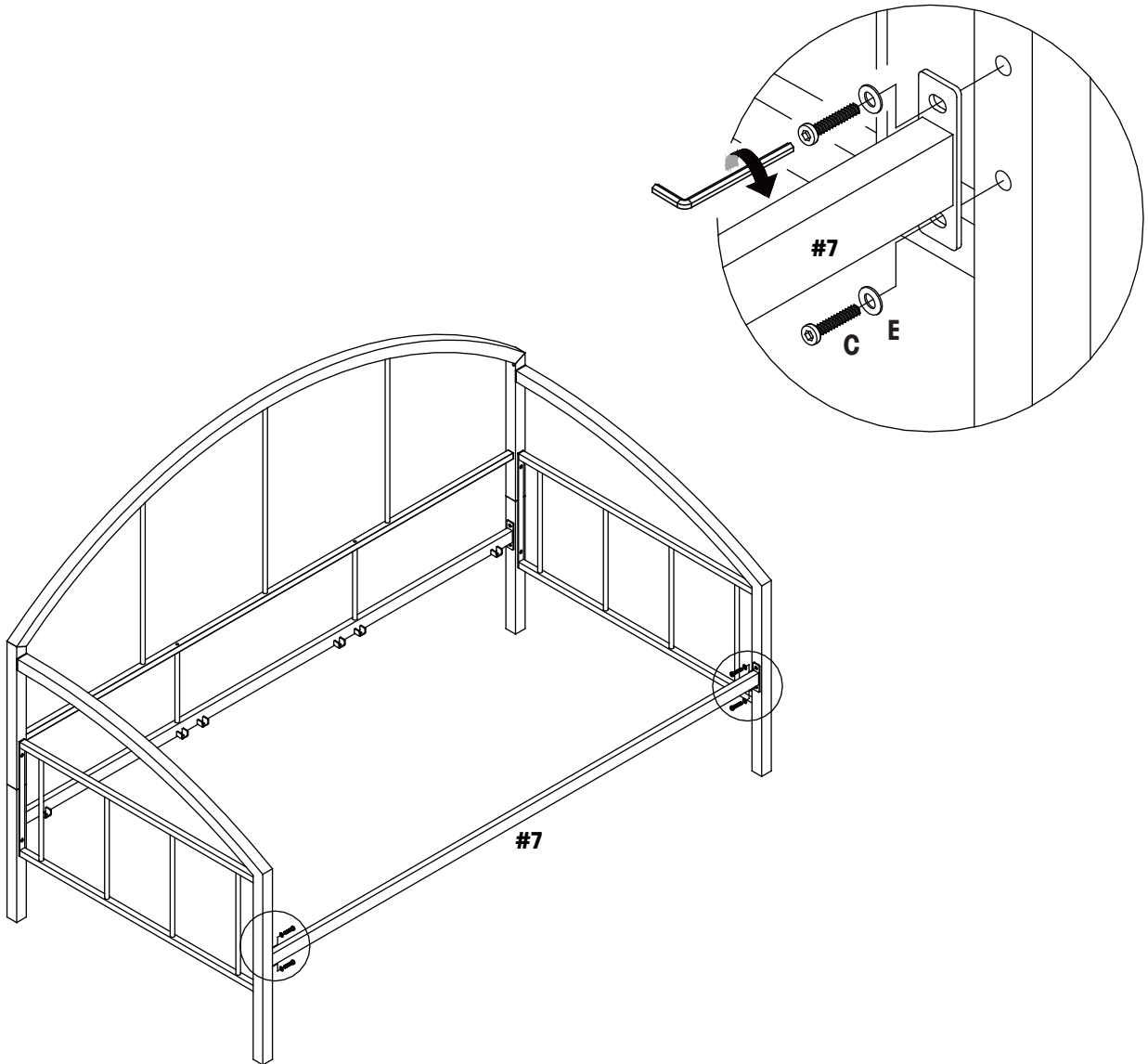

<b>A</b>		<b>02</b>
<b>C</b>		<b>04</b>
<b>E</b>		<b>06</b>

6.





C		04
E		04

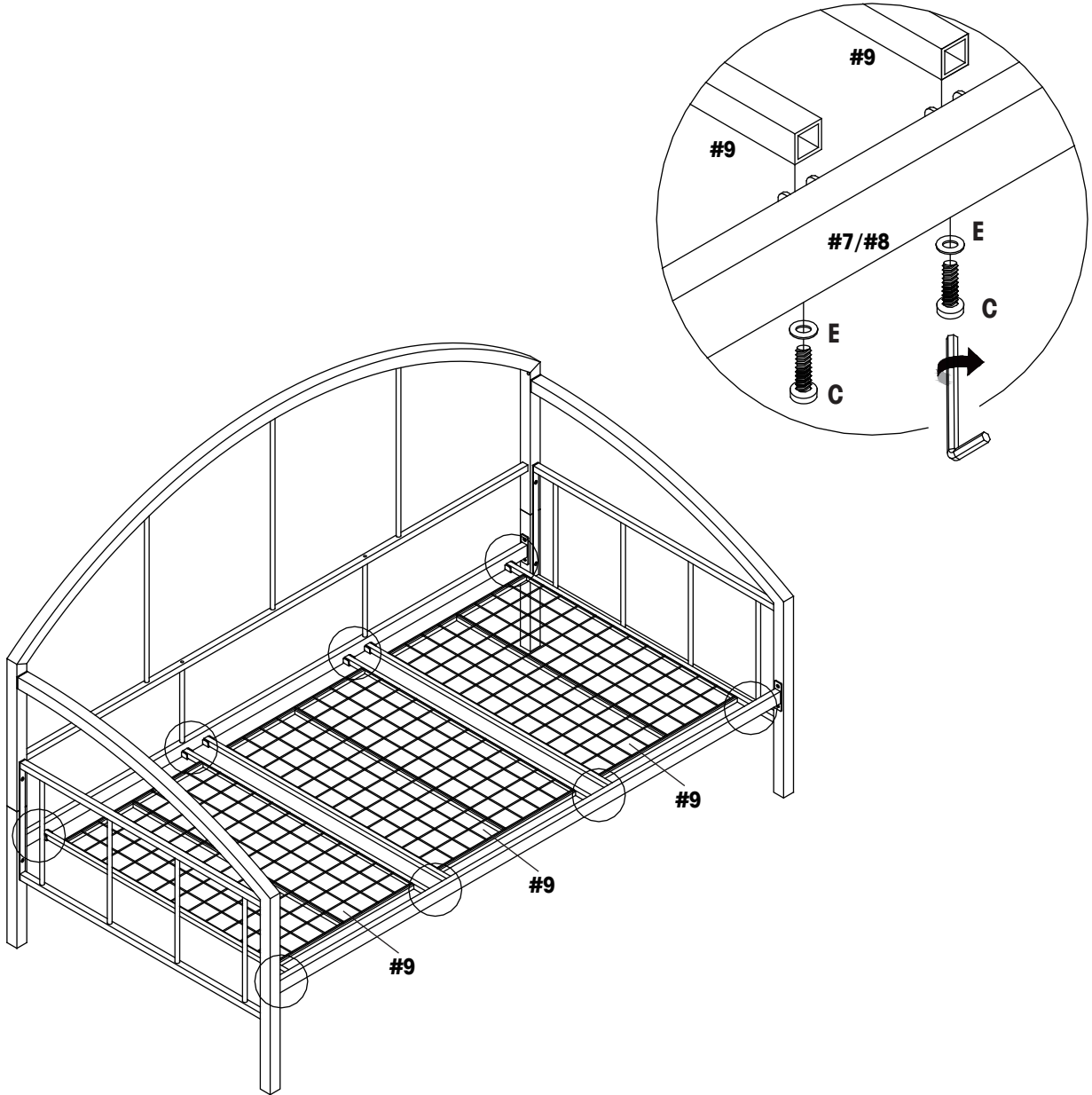

7.



<b>C</b>		<b>12</b>
<b>E</b>		<b>12</b>

8.

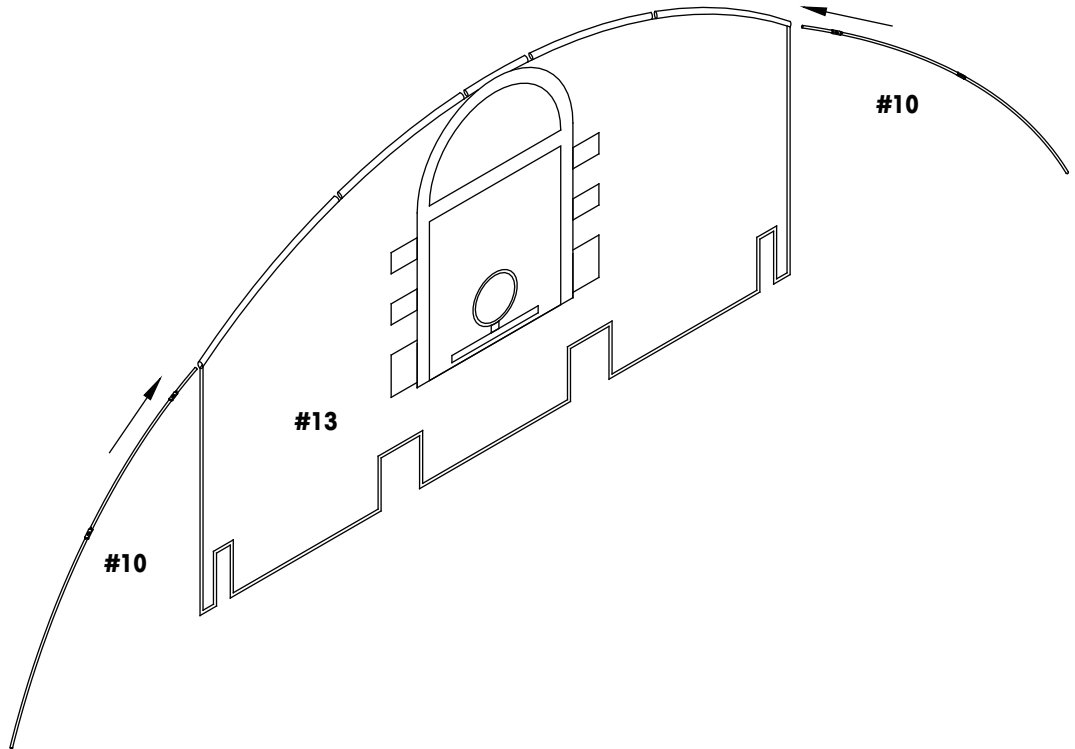

9.

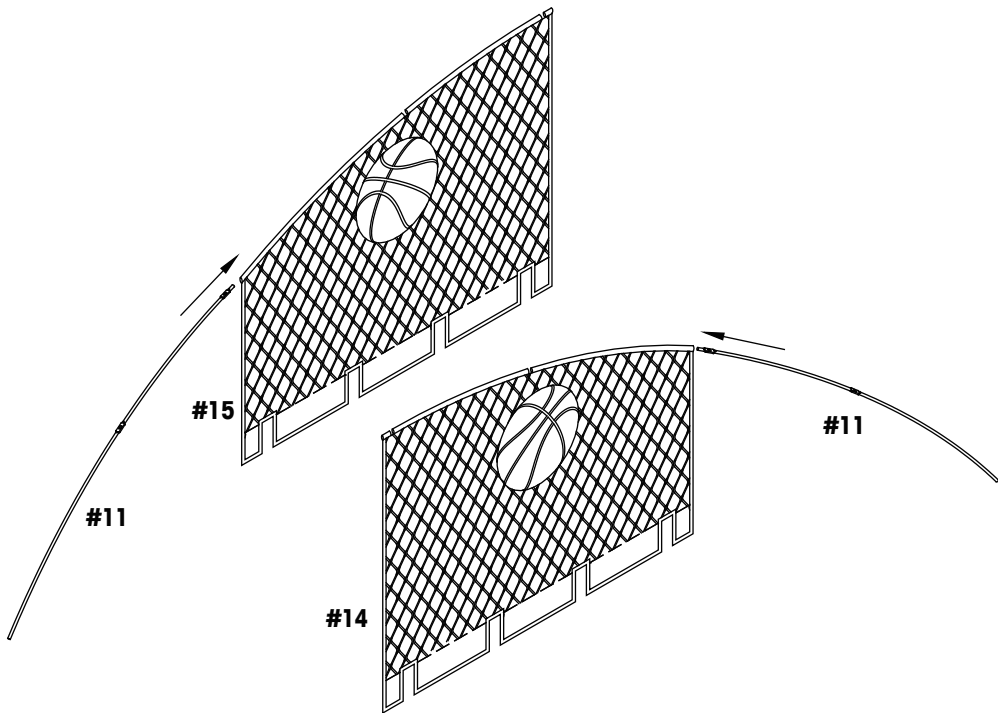

10.

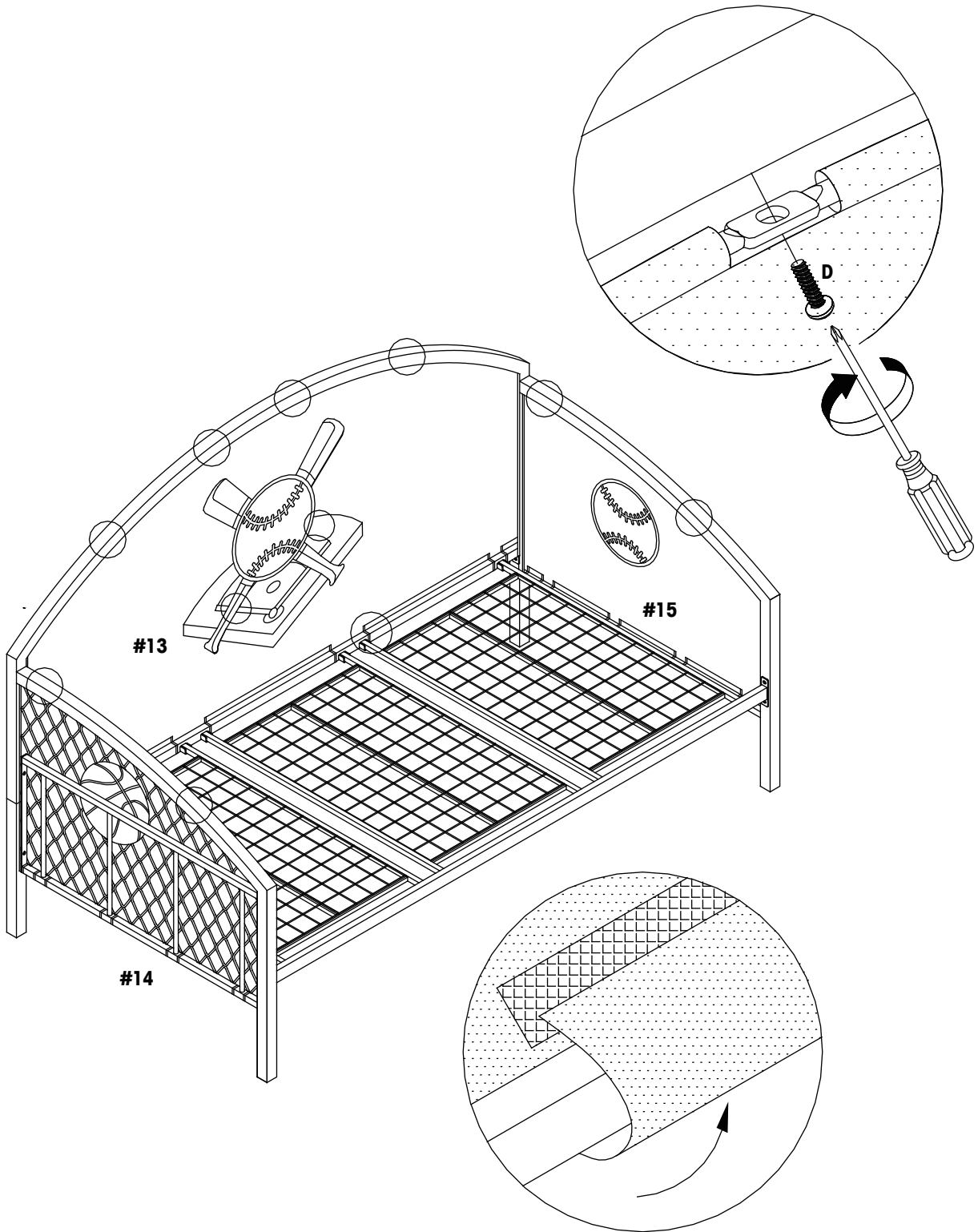

D		8
---	---	---

11.

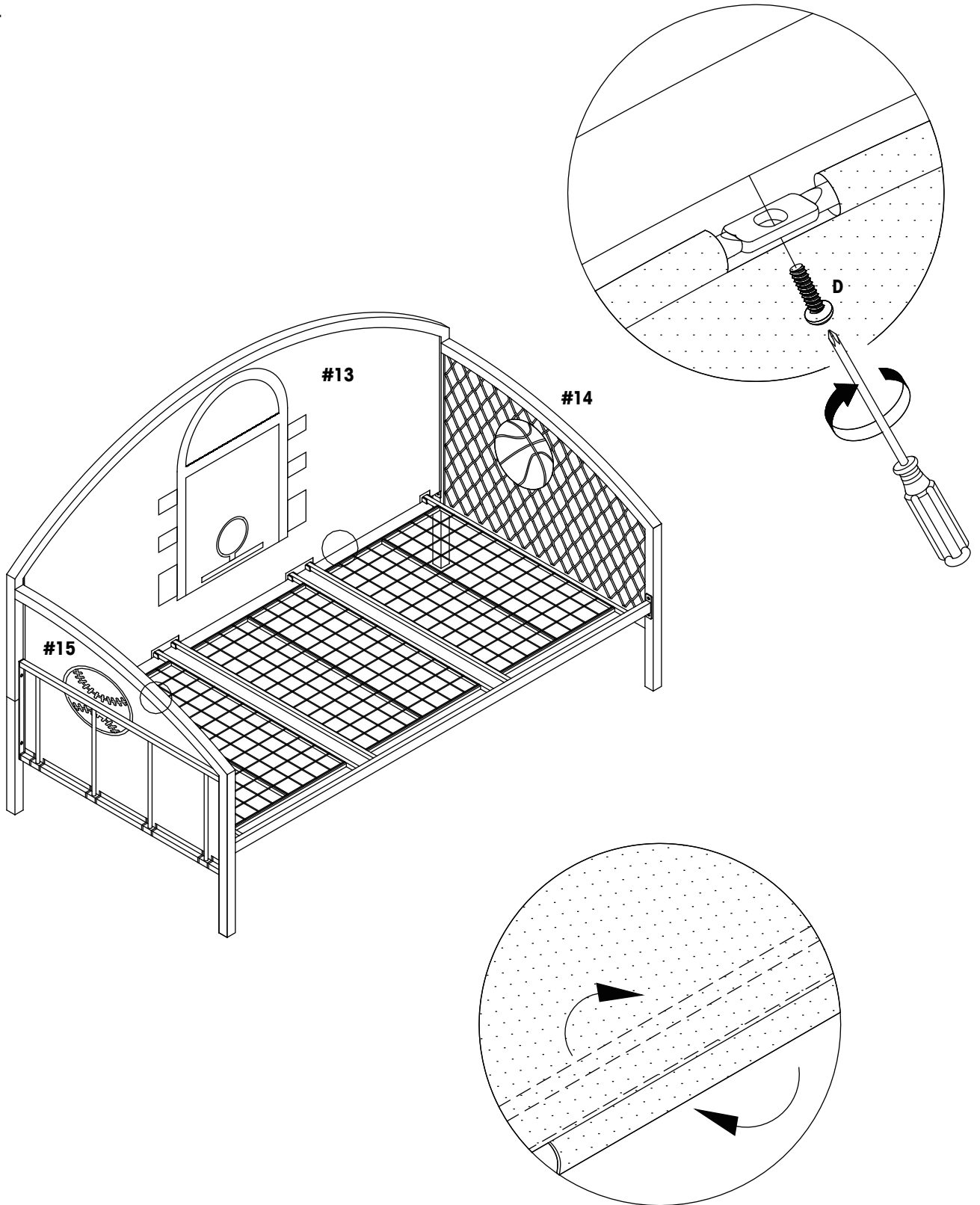

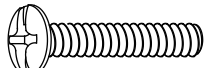
D		8
---	---	---

 **WARNING TO HELP PREVENT SERIOUS OR FATAL INJURIES FROM ENTRAPMENT OR FALLS:**

- Wipe frequently with a soft, dry, lint-free cloth.
- Assembly to be carried out by a competent adult only.
- During assembly children should be kept away from the product due to possible risk of injury.
- Do not use this bed if any components are missing or damaged.
- This bed is intended for use by children over five years of age.
- The maximum child weight or load for the product is 400LBS
- Do not use this buggy bed if any part is broken, torn or missing.
- Use only a mattress 39"Wx75"L with 8"thickness of mattress.
- All assembly fittings should always be tightened properly and checked periodically.
- Bed should not be placed too close to other furniture or windows, and should be placed either tight to any wall or have a gap of at least 300mm between the wall and the side of bed.
- Please contact Powell Customer Service if any parts are missing or defective, contact information is given separately on parts request form.

**STRANGULATION HAZARD** Never attach or hang items to any part of the bed that are not designed for use with the bed; for example, but not limited to, hooks, belts and jump ropes.

**DO NOT REMOVE THIS LABEL, KEEP THESE INSTRUCTIONS FOR FUTURE REFERENCE.**



## LIMITED 6 MONTHS WARRANTY

## GARANTIE LIMITÉE DE 6 MOIS

## GARANTÍA LIMITADA DE 6 MESES

### WHAT IS COVERED

This product is covered under our manufacturer's 6 months limited warranty (L.Powell Acquisition Corp.). To ensure your complete satisfaction, this warrants to the original purchaser that the Powell supplied item is free from defects in material and workmanship, as of the date of purchase, and that it will, under normal use and proper care, remain so for six months after the date of purchase.

Replacement of missing or initially defective parts will be sent, at no charge, for a period of 30 days from the date of purchase with valid proof of purchase providing the parts are available in our warehouse and the item purchased is part of our current inventory.

### WHAT IS NOT COVERED

It remains the customer's responsibility for freight and packaging charges to and from the customer service center. Labor and material charges to remove or replace parts under this warranty are not covered.

This warranty does not cover: Furniture used for commercial purposes, failures caused by improper installation assembly or by improper care, unreasonable or abusive use, freeze damage, acts of God, rust, purchased parts or return freight and packaging charges. Proof of purchase (dated register receipt) is required for warranty claims.

### HOW TO OBTAIN SERVICE

For further information, please contact our customer service department, c/o Linon Home Décor Products, Inc., between 9:00 AM and 5:00 PM Eastern Standard Time, Monday through Friday:

### CUSTOMER SERVICE DEPARTMENT:

- 1) Email address:  
parts@powellcompany.com
- 2) Toll free number:  
800 - 622 - 4456

### QU'EST-CE QUI EST COUVERT

Ce produit est couvert sous une garantie limitée de 6 mois offerte par le fabricant. Afin d'assurer votre entière satisfaction, cela garantit à l'acheteur original que le produit fourni est exempt de défauts de matériaux et de fabrication à compter de la date d'achat, et ce, sous des conditions d'utilisation normales et de soins adéquats, valide pendant six mois après la date d'achat.

Le remplacement de pièces manquantes ou défectueuses dès le départ sera envoyé, sans frais, pour une période de 30 jours suivant la date d'achat avec une preuve d'achat valide pourvu que les pièces soient disponibles dans notre entrepôt et que l'article acheté fait partie de notre inventaire actuel.

### QU'EST-CE QUI N'EST PAS COUVERT

Il y va de la responsabilité du client de couvrir les frais de transport et d'emballage vers et à partir du centre de service après-vente. Les frais de la main-d'œuvre et des matériaux pour retirer les pièces ou les remplacer sous cette garantie ne sont pas couverts.

Cette garantie ne couvre pas : les meubles utilisés à des fins commerciales, les défaillances causées par un mauvais assemblage ou entretien (sans dépasser les limites de poids), l'utilisation déraisonnable ou abusive, les dommages causés par le gel, la rouille, les frais de transport et d'emballage pour des pièces achetées ou retournées. Une preuve d'achat (reçu de caisse daté) est requise pour les réclamations sous garantie.

### COMMENT FAIRE POUR OBTENIR DU SERVICE

Pour de plus amples renseignements, veuillez communiquer avec notre département du service à la clientèle, entre 9 h et 17 h HNE, du lundi au vendredi.

### CENTRE DE SERVICE À LA CLIENTÈLE

- 1) Adresse de courriel :  
parts@powellcompany.com
- 2) Numéro de téléphone sans frais:  
800 - 622 - 4456

### QUÉ ESTÁ CUBIERTO

Este producto está cubierto por la garantía limitada de 6 meses de nuestro fabricante. Para asegurar su total satisfacción, ésta garantiza al comprador original que el artículo proporcionado se encuentra libre de defectos materiales y de fabricación, a partir de la fecha de compra, y que permanecerá en tal estado, sometido a un uso normal y cuidados adecuados, durante los seis meses posteriores a la fecha de la compra.

Las partes faltantes o que presenten defectos al inicio de ese período de tiempo serán enviadas sin cargo, durante un lapso de 30 días a partir de la fecha de compra, mediante la presentación de un comprobante de compra válido, siempre que las partes estén disponibles en nuestro almacén y el artículo adquirido sea parte de nuestro inventario actual.

### QUÉ NO ESTÁ CUBIERTO

El cliente asumirá los costos de flete y empaque hacia y desde el centro de servicio de cliente. Los cargos de material y mano de obra para extraer o reemplazar partes en el marco de la garantía no están cubiertos.

Esta garantía no cubre: muebles utilizados con fines comerciales, fallas causadas por montaje de instalación inadecuados o uso indebido (se recomienda no exceder los límites de peso), uso no razonable o abusivo, daños por congelación, oxidación, partes compradas, flete de devolución y cargos de empaque. Se exigirá el comprobante de compra (la factura de registro con fecha) para hacer valer la garantía.

### CÓMO OBTENER SERVICIO

Si desea más información, póngase en contacto con nuestro departamento de servicio al cliente, de lunes a viernes entre las 9:00 a.m. y las 5:00 p.m., hora estándar de los Estados Unidos.

### DEPARTAMENTO DE SERVICIO AL CLIENTE

- 1) Correo electrónico:  
parts@powellcompany.com
- 2) Número telefónico gratuito:  
800 - 622 - 4456

# 15Y8174

MADE IN CHINA  
FABRIQUÉ EN CHINE  
HECHO EN CHINA

(YZ - 7575)

