

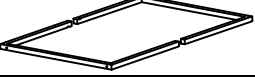







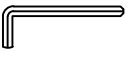

ASSEMBLY INSTRUCTIONS

ITEM NO: T257-04
End Table

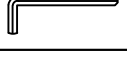
Thank you for purchasing this quality product. Place all wooden parts on a clean and smooth surface such as a rug or carpet to avoid the parts from being scratched. Be sure to check all packing materials carefully for small parts may have come loose inside the carton during shipment, clarify and count all parts and compare with the parts list below. Do not tighten all screws / bolts until all completely assembled.

Part List		
No.	Description	Q.ty
A	TOP 	1PC
B	METAL LEG 	2 PCS
C	METAL FRAME 	2 PCS

Hardware List				
No.	Description	Sketch	Size	Q.ty
1	ALLEY KEY		M5 x 60mm	1PC
2	JCBB BOLT		M8 x 60mm	4 PCS
3	SPRING WASHER		M8 x 13mm	4 PCS
4	FLAT WASHER		M8 x 19mm	4 PCS
5	ALLEY KEY		M4 x 60mm	1PC
6	JCBC BOLT		M6 x 40mm	4 PCS
7	SPRING WASHER		M6 x 13mm	4 PCS
8	FLAT WASHER		M6 x 13mm	4 PCS
9	ADJUSTER		M6 x 23mm	4 PCS

These parts are cumbersome and heavy. Therefore, two people are recommended in order to prevent personal injury and insure the parts are not damaged during the assembly.

Important Notes

- *Keep all hardware parts out of reach of children!
- *Tighten screws periodically! With the use of this product bolts and screw may become loose over time
- *Don't attempt to modify parts!

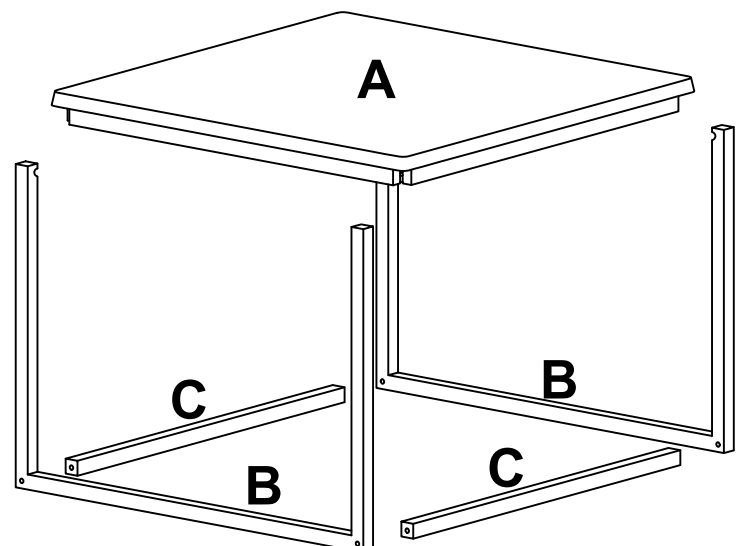

ASSEMBLY INSTRUCTIONS

ITEM NO: T257-04
End Table

STEP 1

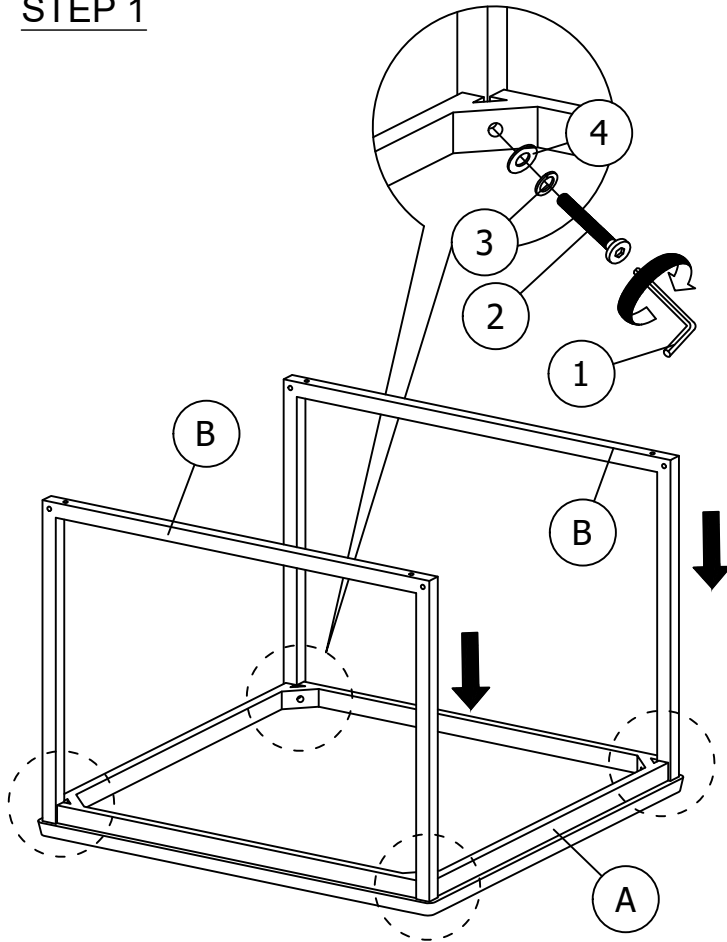

STEP 2

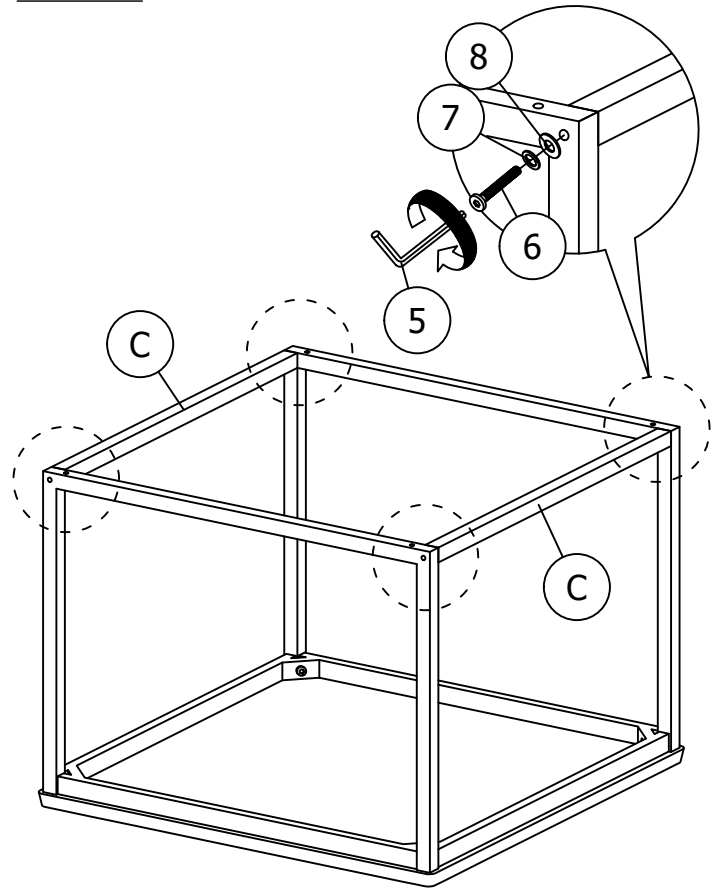

STEP 3

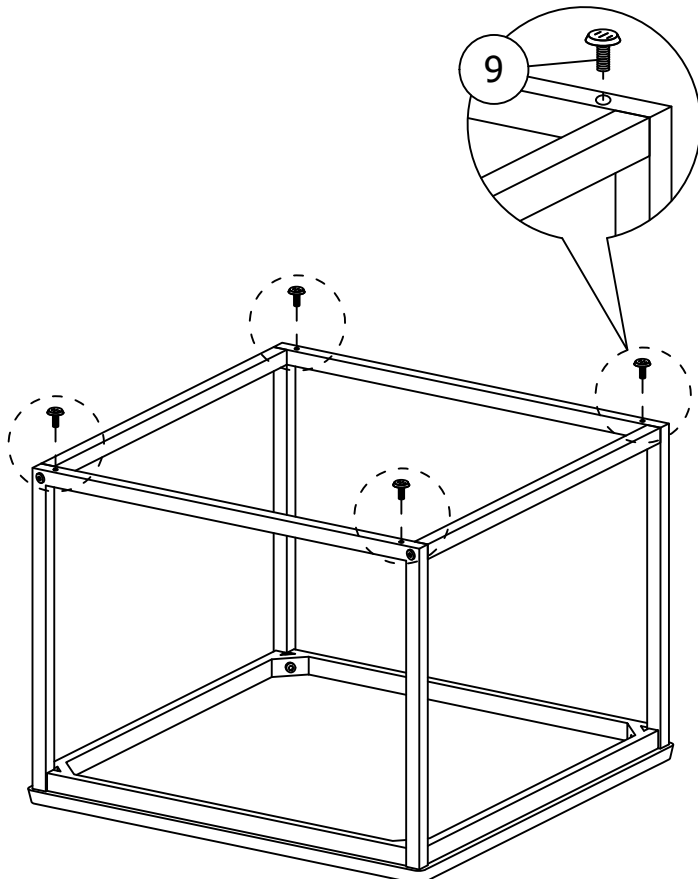

STEP 4

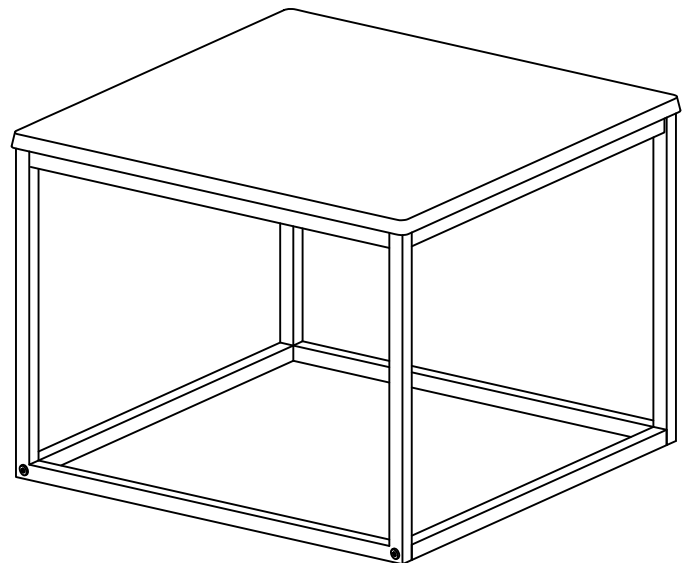

Cleaning instruction: Clean using soft cloth

Made in Malaysia