

# Assembly Instructions for P368-01

Read Instructions carefully prior to assembly.

Thank you for purchasing this high quality product. Check carefully for small parts which may have come loose during shipment.

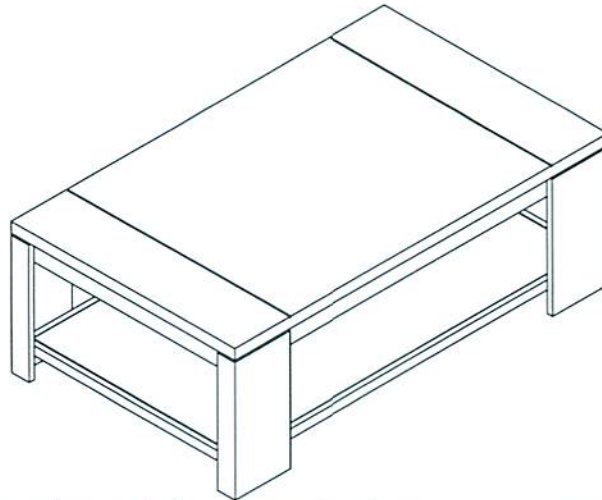

Begin by placing the table upside down on a smooth surface please make sure the surface is not abrasive.

## P368-01 RECT.CKTL TABLE

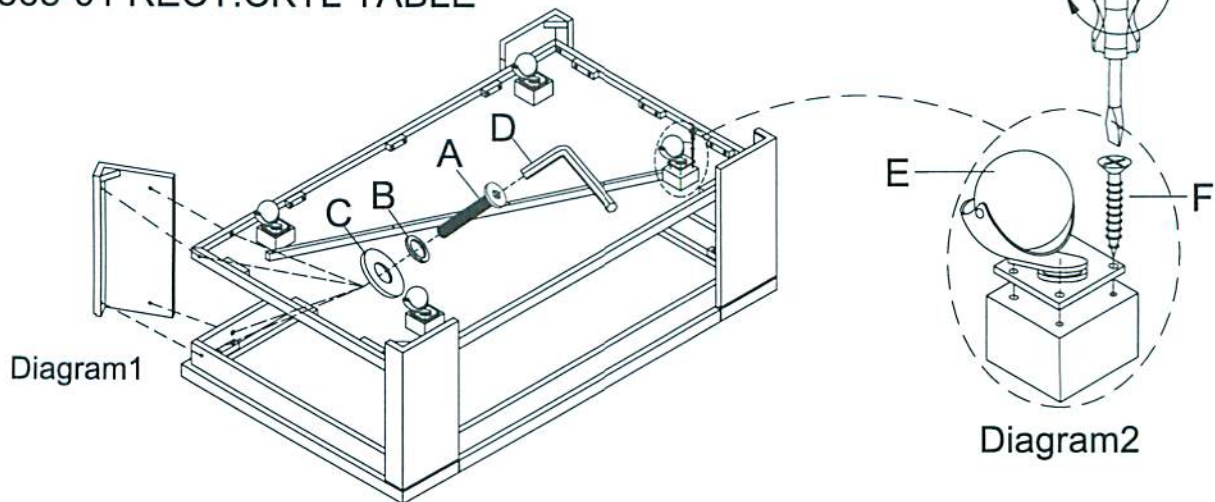

HARDWARE LIST:							
No.	DRAWING	Q'TY	DESCRIPTION	No.	DRAWING	Q'TY	DESCRIPTION
A		16PCS	BOLT(Ø1/4"*1-1/4"L)	B		16PCS	SPRING WASHER (Ø1/4"*12mm)
C		16PCS	WASHER(Ø1/4"*16mm)	D		1PC	ALLEN WRENCH(4mm)
E		4PCS	CASTERS(Ø50mm)	F		16PCS	SCREWS(#6*5/8"L)

- 1) Assemble 3 legs with table top by using parts A. B. C. D. as shown in Diagram 1.
- 2) Install shelf to slots and assemble last leg with A. B. C. D. as shown in Diagram 1. fasten A. B. C. D.
- 3) Casters by inseriting the screws into pre-bored holes in the wood blocks as shown in Diagram 2.
- 4) Place the table into position.