











# ASSEMBLY INSTRUCTIONS

ITEM NO.: 1831-40  
DESK

Thank you for purchasing this quality product. Place all wooden parts on a clean and smooth surface such as a rug or carpet to avoid the parts from being scratched. Be sure to check all packing materials carefully for small parts may have come loose inside the carton during shipment, clarify and count all parts and compare with the parts list below. Do not tighten all screws / bolts until all completely assembled.

Parts List		
No.	Description	Q.ty
1	Shelf Panel 1	1PC
2	Shelf Panel 2	1PC
3	Shelf Back Panel	2PCS
4	Table Top	1PC
5	Left Panel	1PC
6	Right Panel	1PC
7	Back Panel	1PC
8	Drawer Front	1PC
9	Drawer Side	2PCS
10	Drawer Back	1PC
11	Drawer Bottom	1PC
12	Metal Leg	2PCS

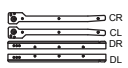
Hardware List				
No.	Description	Sketch	Size	Q.ty
A	Wood Dowels		M8x 30mm	8pcs
B	Cam Lock		D15mm x T11mm	11pcs
C	Cam Bolts		M6 x 40mm	11pcs
D	Screws		Ø3.5 x 12mm	12pcs
E	Screws		Ø4 x 32mm	10pcs
F	Screws		Ø4 x 38mm	8pcs
G	Screws		Ø4 x 45mm	16pcs
H	Nail		Ø1.8 x 18mm	10pcs
I	Handle		7050	1pc
J	Handle Screw		Ø4 x 28mm	2pcs
K	Drawer Slide		350mm	4pcs/ 2sets

## NOTE : YOU WILL ALSO NEED A SCREWDRIVER (NOT PROVIDED)

These parts are cumbersome and heavy. Therefore, two people are recommended in order to prevent personal injury and insure the parts are not damaged during the assembly.

### Important Notes

- \*Keep all hardware parts out of reach of children!
- \*Tighten screws periodically! With the use of this product bolts and screws may become loose over time!
- \*Don't attempt to modify parts!

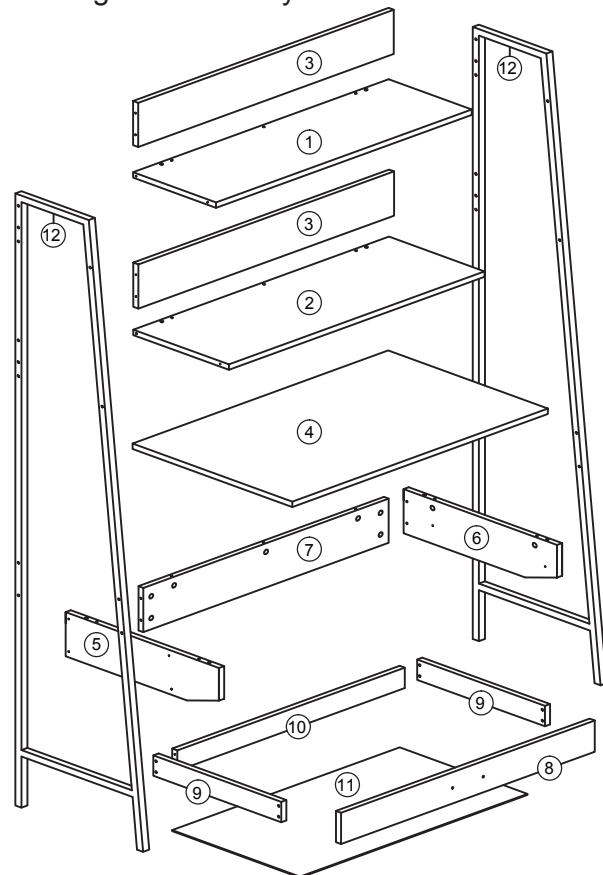

# ASSEMBLY INSTRUCTIONS

ITEM NO.: I831-40  
DESK

## STEP 1:

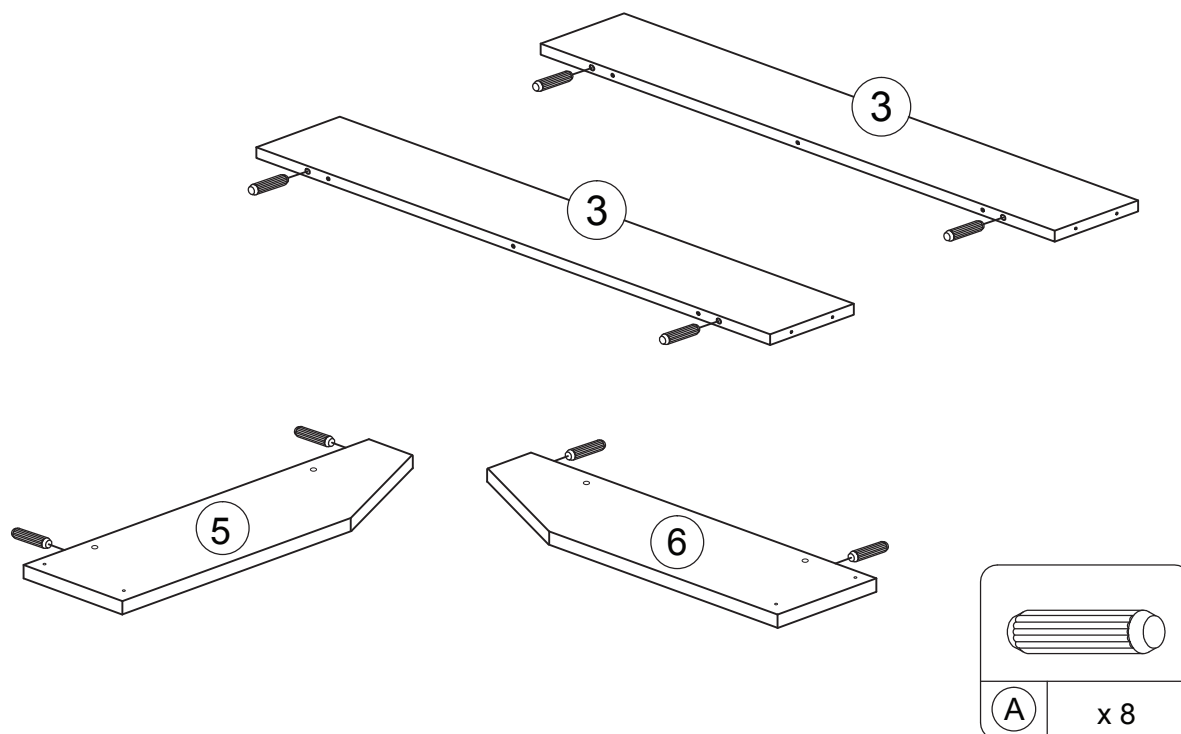

## STEP 2:

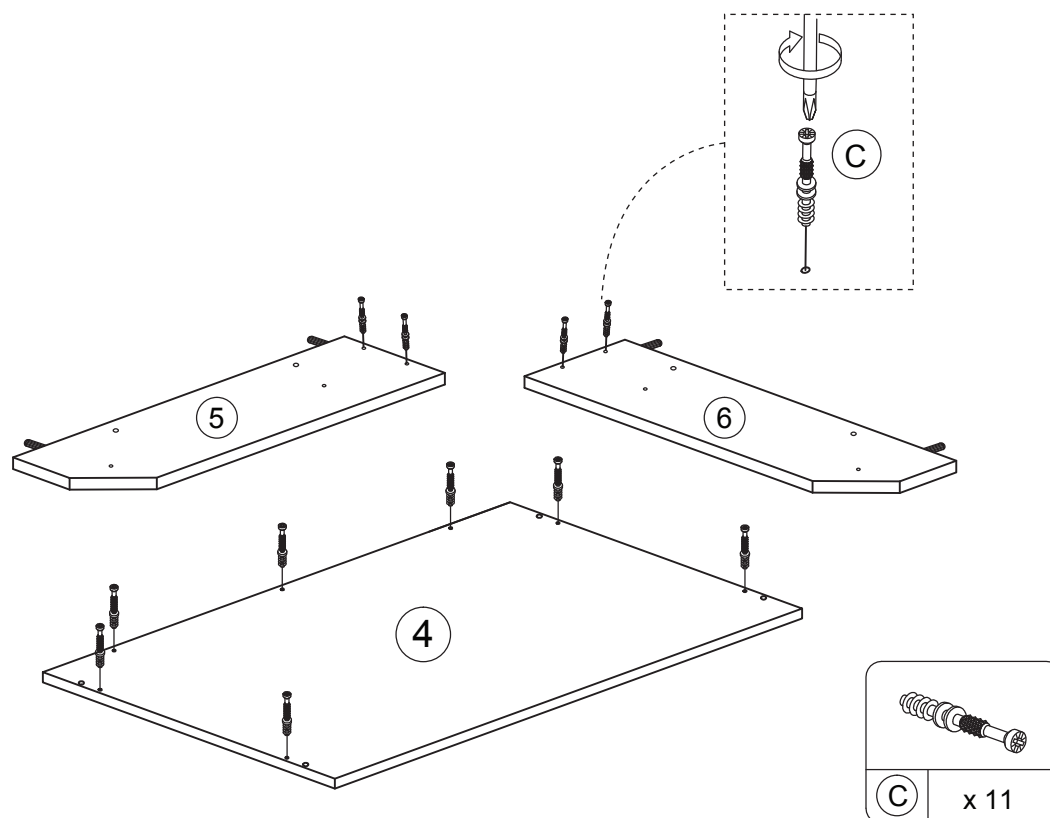

# ASSEMBLY INSTRUCTIONS

ITEM NO.: I831-40  
DESK

## STEP 3:

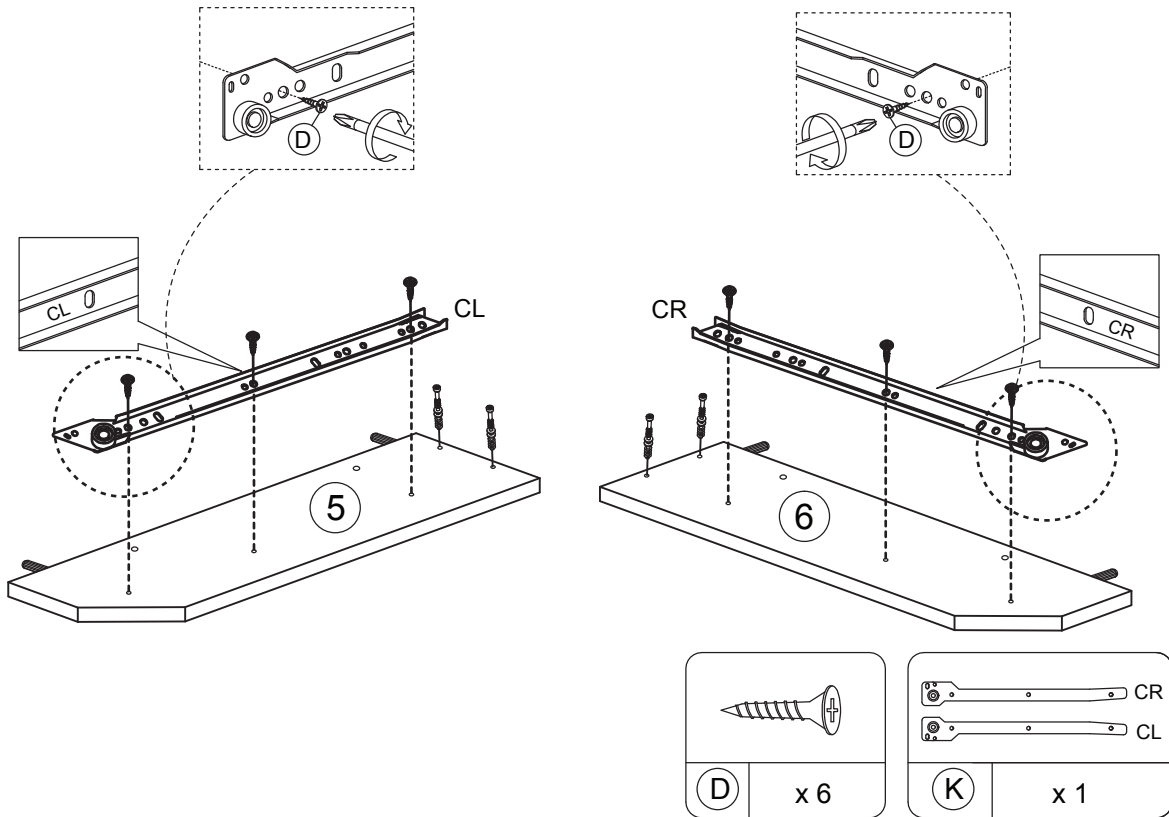

## STEP 4:

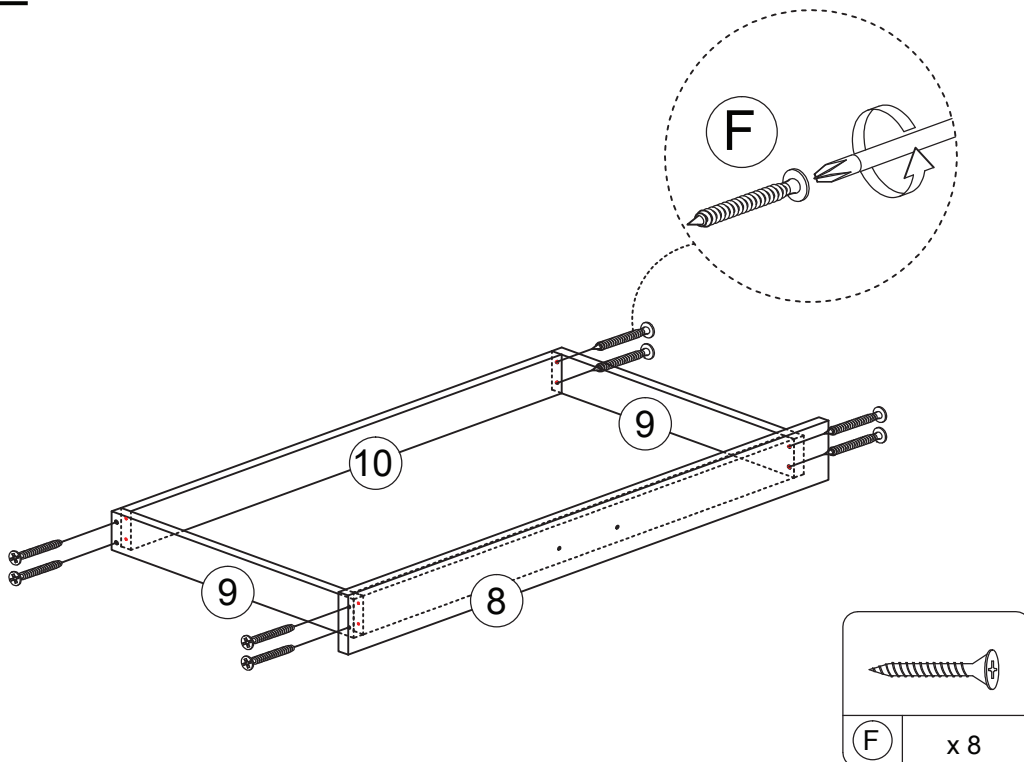

Cleaning instruction: Clean using soft cloth

Made in Malaysia

# ASSEMBLY INSTRUCTIONS

ITEM NO.: I831-40  
DESK

## STEP 5:

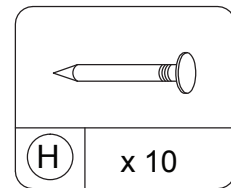
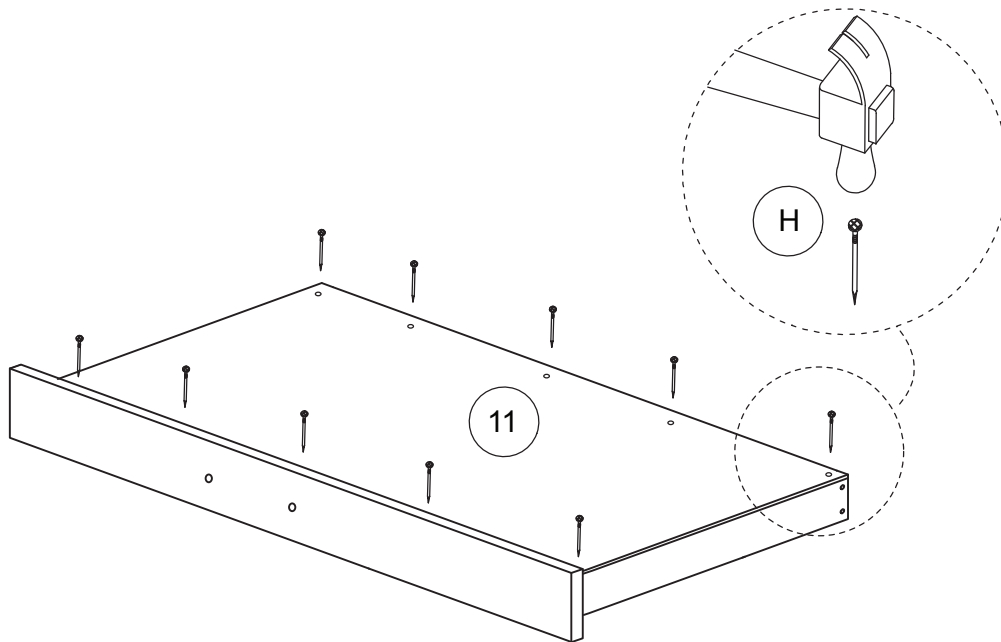

## STEP 6:

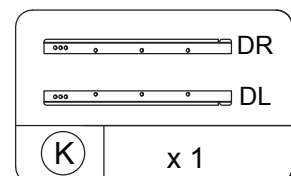
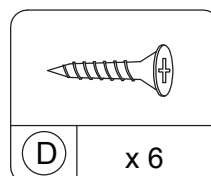
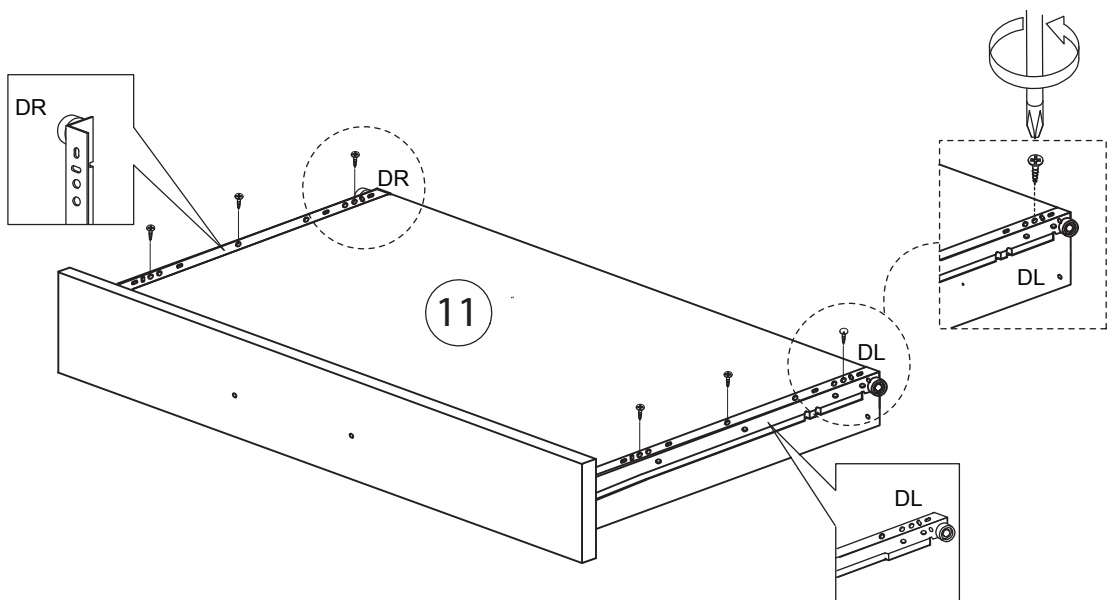

# ASSEMBLY INSTRUCTIONS

ITEM NO.: I831-40  
DESK

## STEP 7:

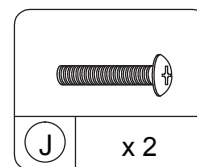
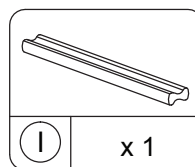
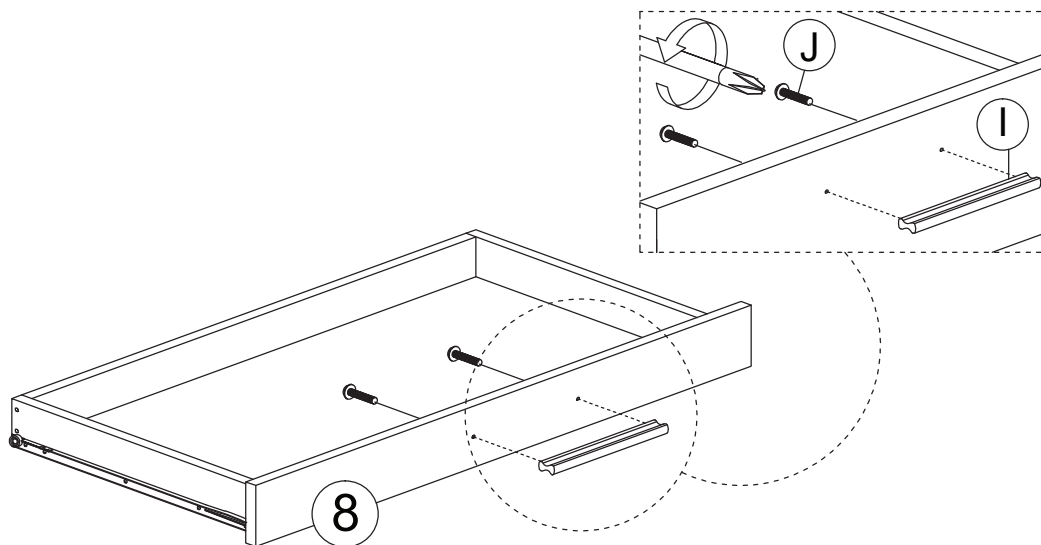

## STEP 8:

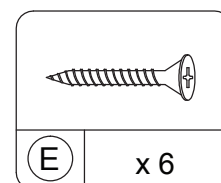
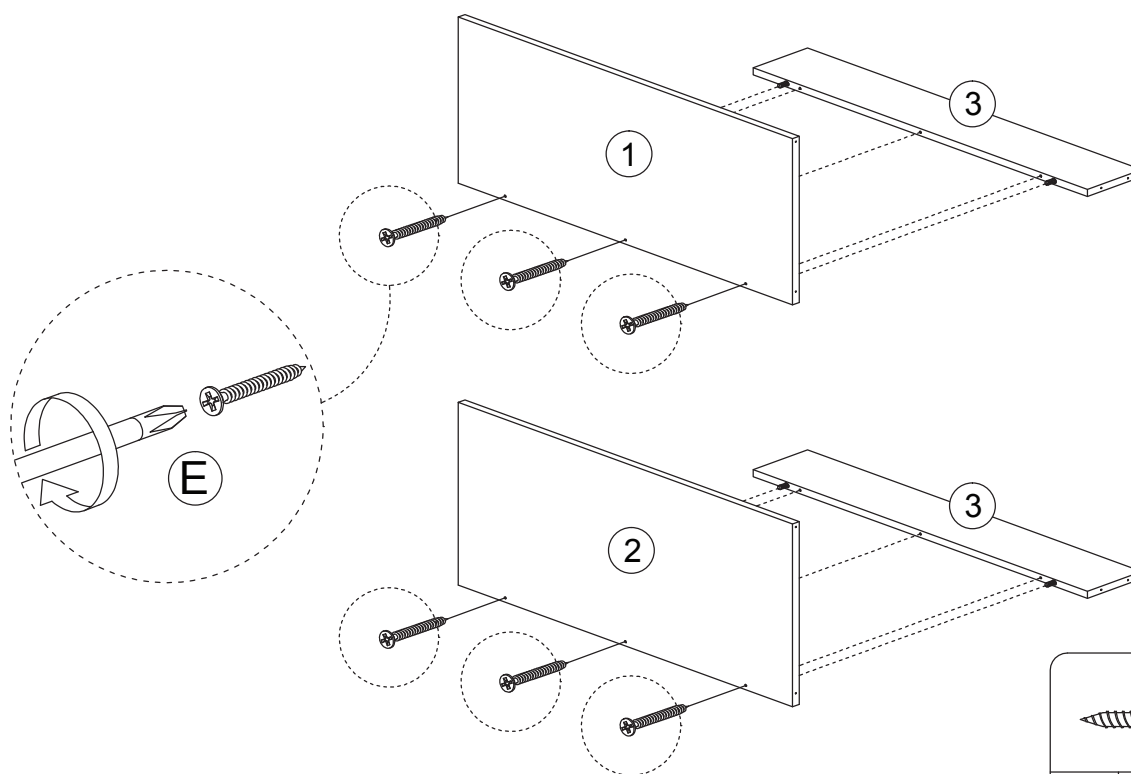

# ASSEMBLY INSTRUCTIONS

ITEM NO.: I831-40  
DESK

## STEP 9:

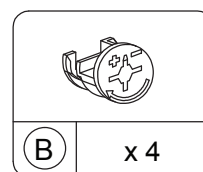
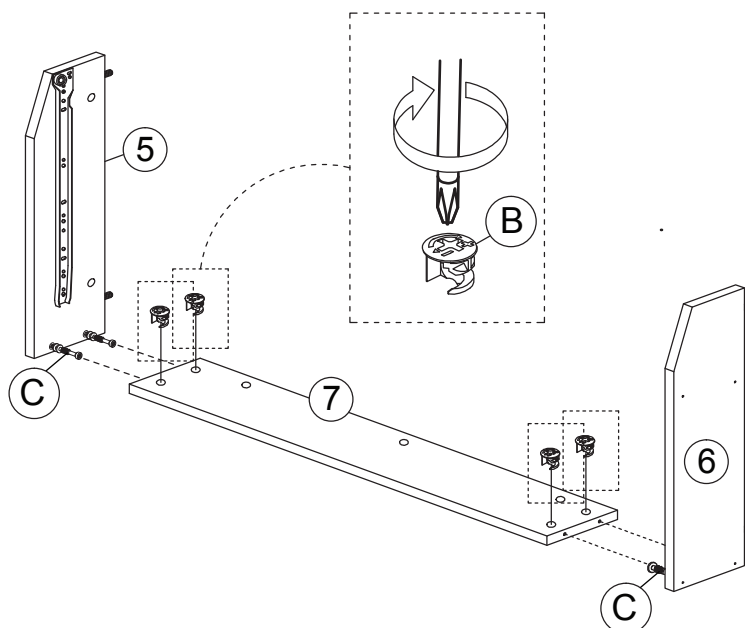

## STEP 10:

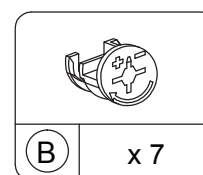
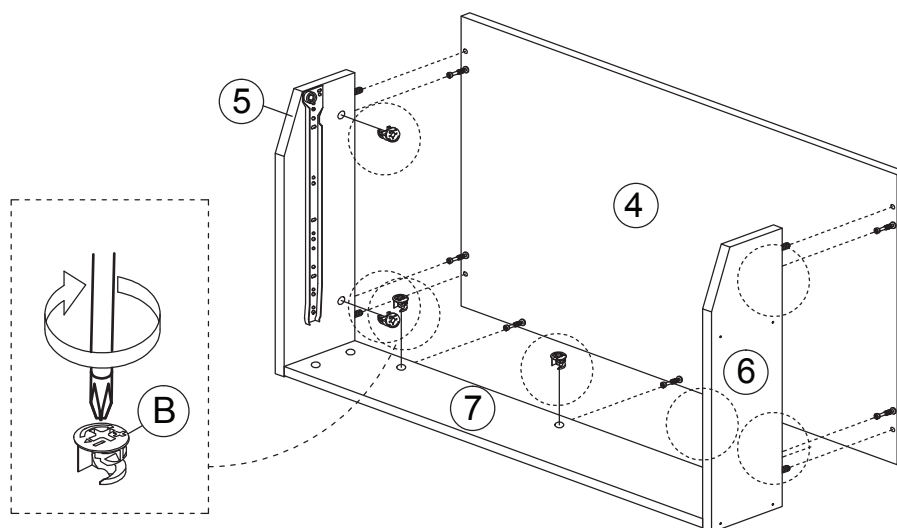

# ASSEMBLY INSTRUCTIONS

ITEM NO.: I831-40  
DESK

## STEP 11:

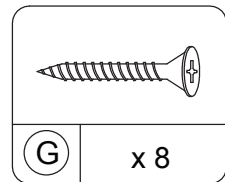
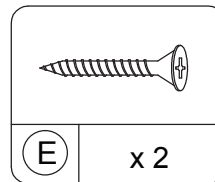
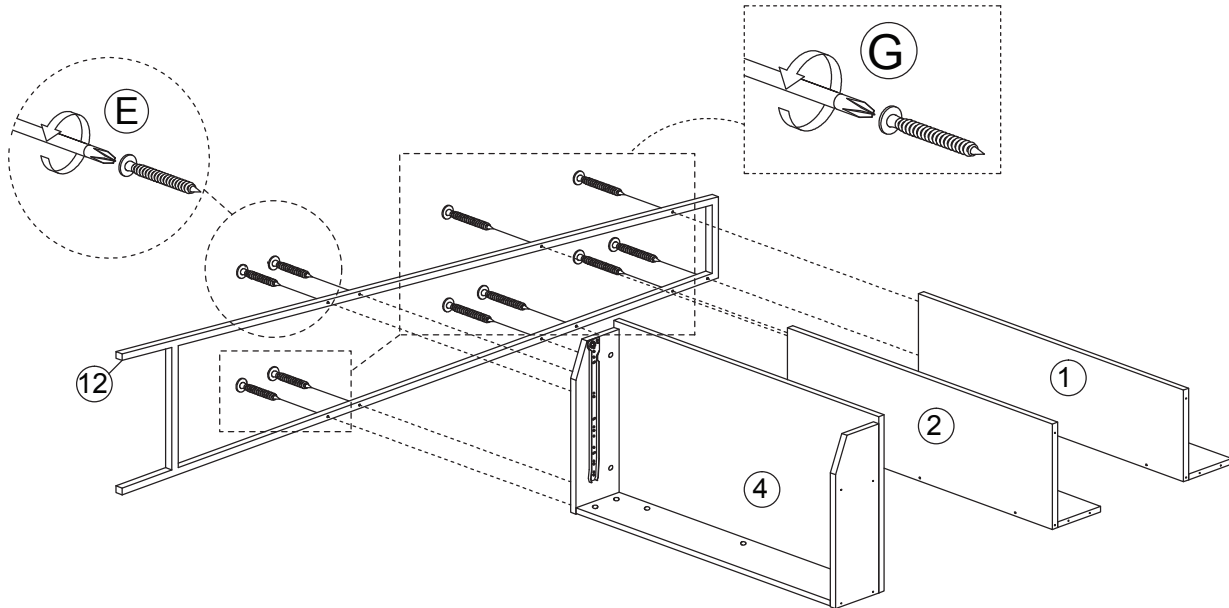

## STEP 12:

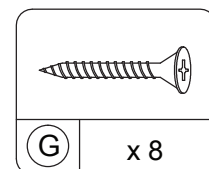
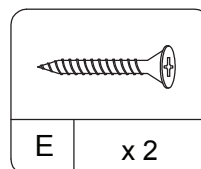
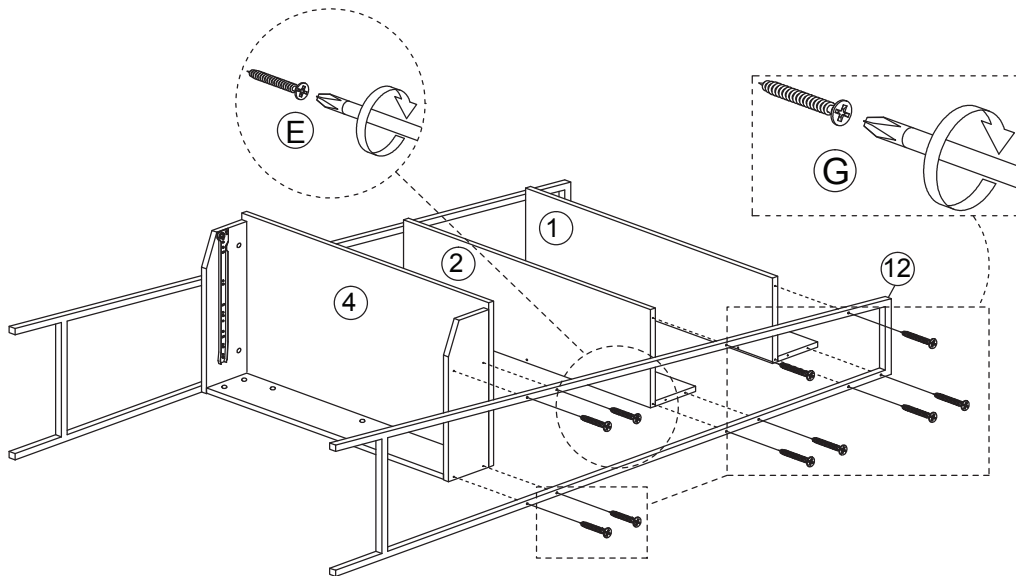

Cleaning instruction: Clean using soft cloth

Made in Malaysia

# ASSEMBLY INSTRUCTIONS

ITEM NO.: 1831-40  
DESK

## STEP 13:

