

ASSEMBLY INSTRUCTION





Item No: I724

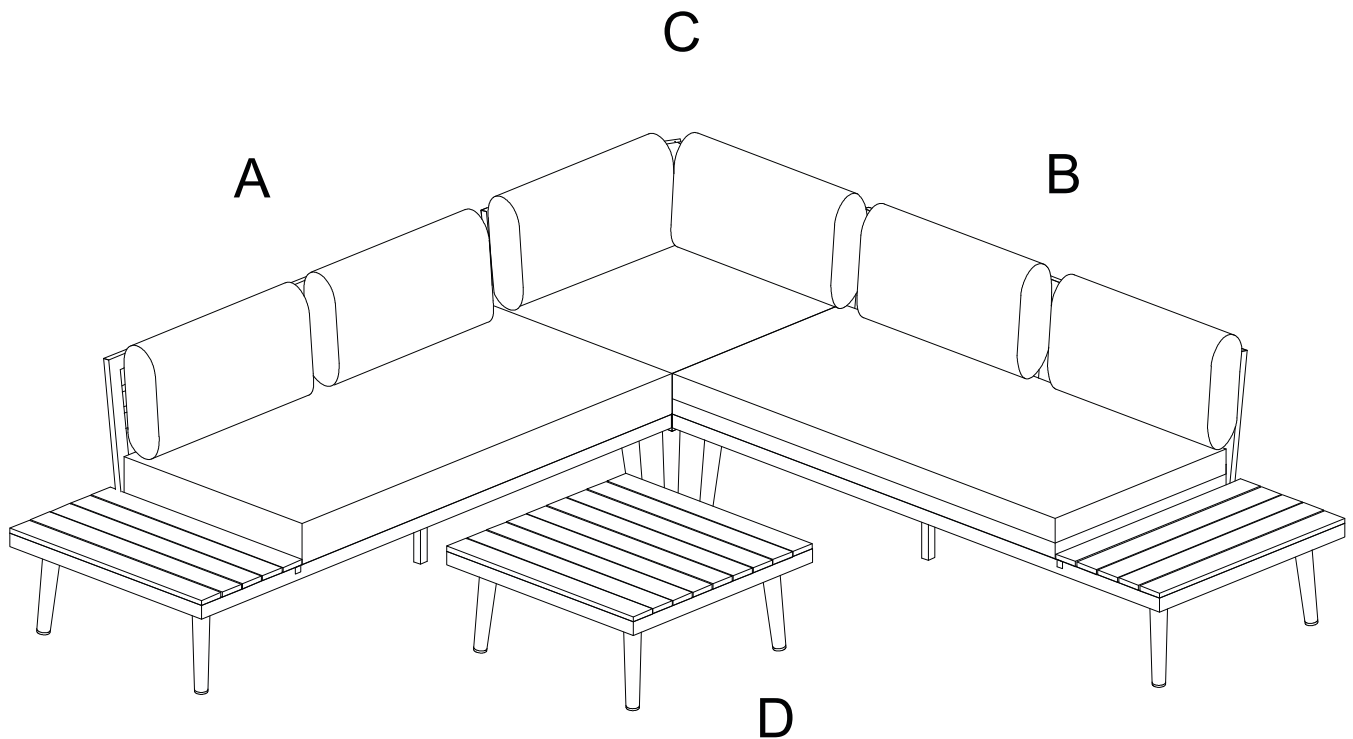

Description: CORNER SOFA

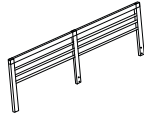
IMPORTANT NOTE:

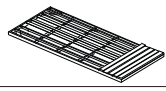
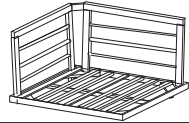
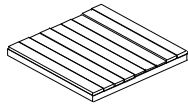
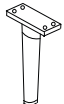
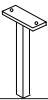
- Place all parts on a clean and smooth surface such as a rug or carpet to avoid the parts from being scratched.
- Check to be sure that you have all parts and hardware.
- Remove all wrapping materials, including staples & packing straps before you start to assemble
- Do not tighten all screws/bolts until all completely assembled.
- Keep all hardware parts out of reach of children.

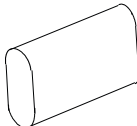
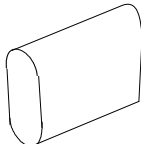
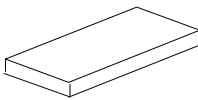
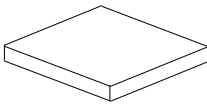

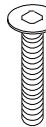
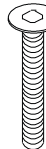
I724	NO	TOTAL PART		QTY
		DESCRIPTION		
	A		Bench Back	2 PCS
	B		Right Bench	1 PC
	C		Left Bench	1 PC
	D		Corner Bench	1 PC
	E		Table Top	1 PC
	F		Leg	16 PCS
	G		Leg Support	2 PCS
	H		Magic Tape	2 PCS
	I		Bench Back Cushion	4 PCS
	J		Corner Bench Back Cushion	2 PCS
	K		Bench Cushion	2 PCS
	L		Corner Bench Cushion	1 PC

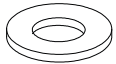
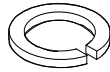
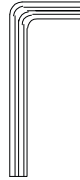
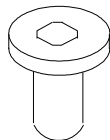
I724	NO	TOTAL PART		QTY
		DESCRIPTION		
	1		JCBC Bolts M16X 15	68 PCS
	2		JCBC Bolts M16x20	6 PCS
	3		JCBC Bolts M16x50	6 PCS
	4		Flat Washer M6x16	74 PCS
	5		Flat Washer M6x19	6 PCS
	6		Spring Washer M6x13MM	80 PCS
	7		Allen Key	6 PCS
	8		Socket Head Bolts M6x15	6 PCS

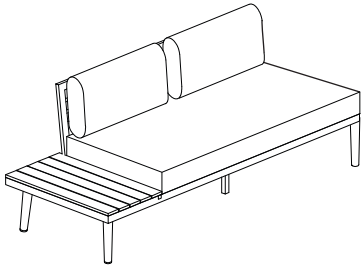



IMPORTANT NOTE:

- Place all parts on a clean and smooth surface such as a rug or carpet to avoid the parts from being scratched.
- Check to be sure that you have all parts and hardware.
- Remove all wrapping materials, including staples & packing
- Do not tighten all screws/bolts until all completely assembled.
- Keep all hardware parts out of reach of children.

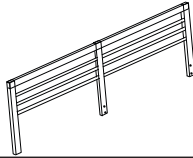
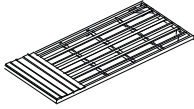
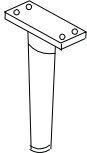
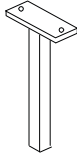
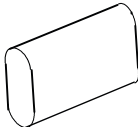
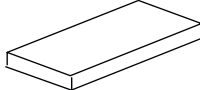
Right Bench (A)

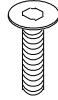
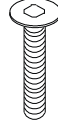
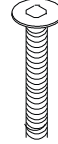
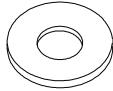
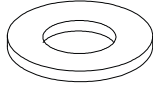
L724-LBRB	PART LIST		
	NO	DESCRIPTION	QTY
	A	 Bench Back	1 PC
	B	 Right bench	1 PC
	F	 Bench Leg	4 PCS
	G	 Leg Support	1 PC
	I	 Bench Back Cushion	2 PCS
	K	 Bench Cushion	1 PC

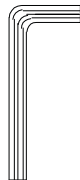
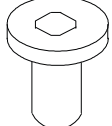
L724	PART LIST		
	NO	DESCRIPTION	QTY
	1	 JCBC Bolt M6x15	18 PCS
	2	 JCBC Bolt M6x20	3 PCS
	3	 JCBC Bolt M6x50	3 PCS
	4	 Flat Washer M6x16	21 PCS
	5	 Flat Washer M6x19	3 PCS
	6	 Spring Washer M6x13	24 PCS
	7	 Allen key	2 PCS
	8	 Socket Head Bolt	3 PCS

STEP 1

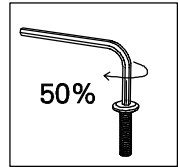
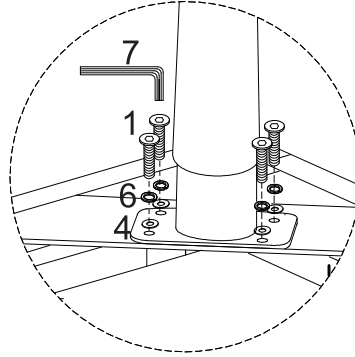
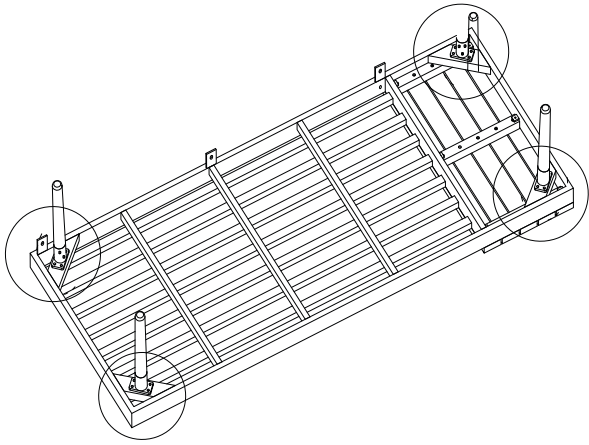

STEP 2

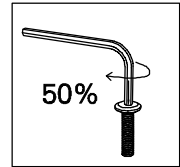
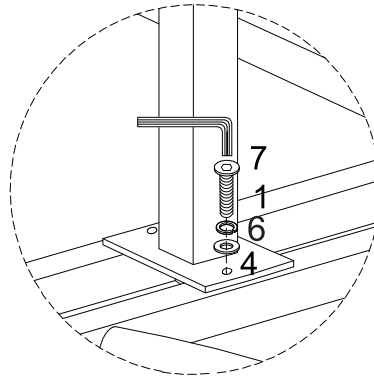
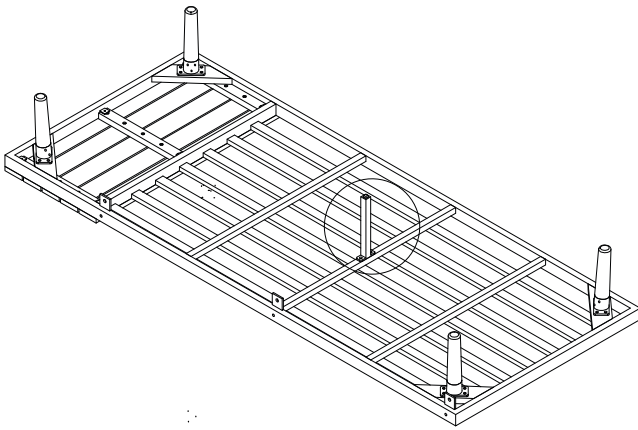

STEP 3

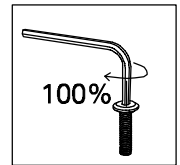
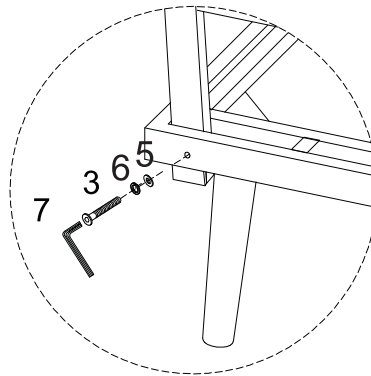
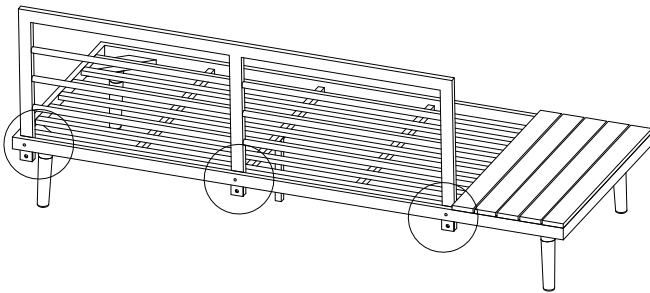

STEP 4

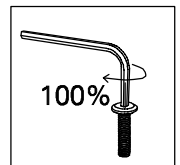
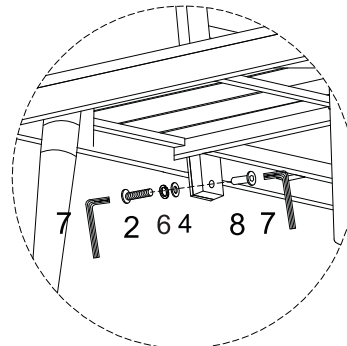
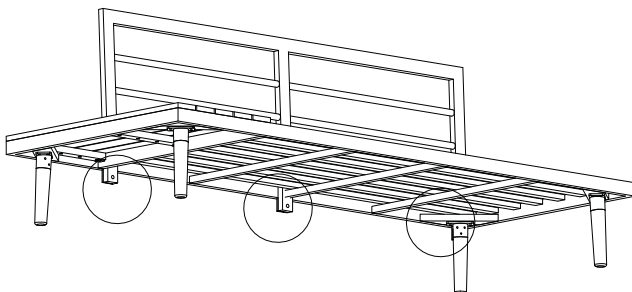

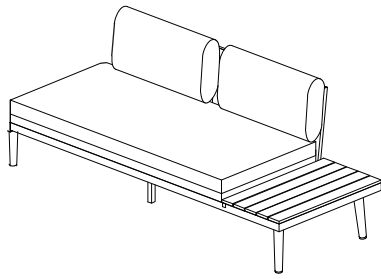

IMPORTANT NOTE:

- Place all parts on a clean and smooth surface such as a rug or carpet to avoid the parts from being scratched.
- Check to be sure that you have all parts and hardware.
- Remove all wrapping materials, including staples & packing
- Do not tighten all screws/bolts until all completely assembled.
- Keep all hardware parts out of reach of children.

Left Bench(B)

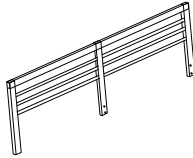
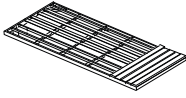
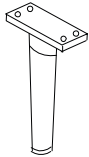
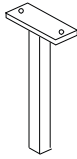
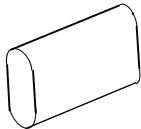
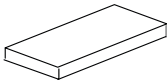
L724-LBRB	PART LIST		
	NO	DESCRIPTION	QTY
A		Bench Back	1 PC
C		Left bench	1 PC
F		Leg	4 PCS
G		Leg Support	1 PC
I		Bench Back Cushion	2 PCS
K		Bench Cushion	1 PC

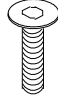
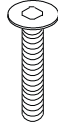
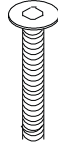
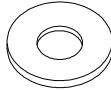
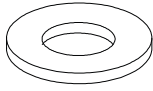
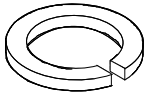
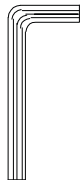
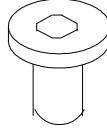
L724	PART LIST		
	NO	DESCRIPTION	QTY
1		JCBC Bolt M6x15	18 PCS
2		JCBC Bolt M6x20	3 PCS
3		JCBC Bolt M6x50	3 PCS
4		Flat Washer M6x16	21 PCS
5		Flat Washer M6x19	3 PCS
6		Spring Washer M6x13	24 PCS
7		Allen key	2 PCS
8		Socket Head Bolt	3 PCS

STEP 1

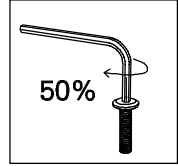
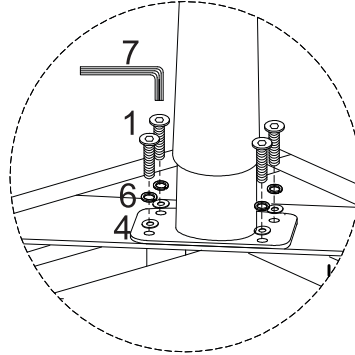
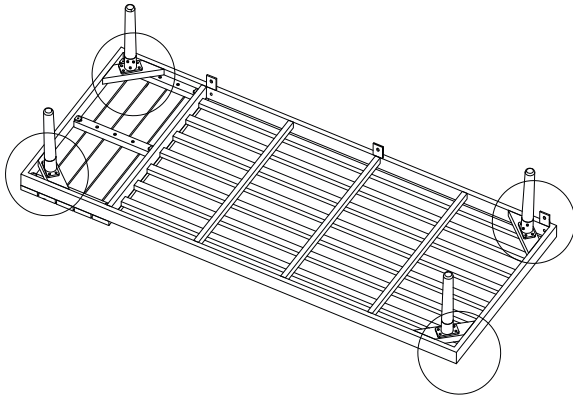

STEP 2

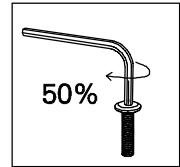
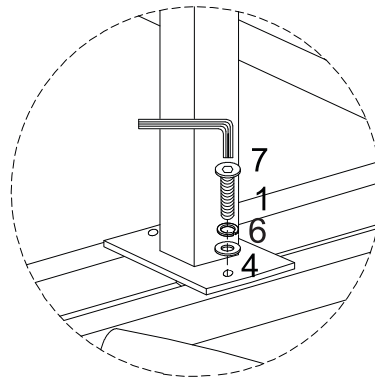
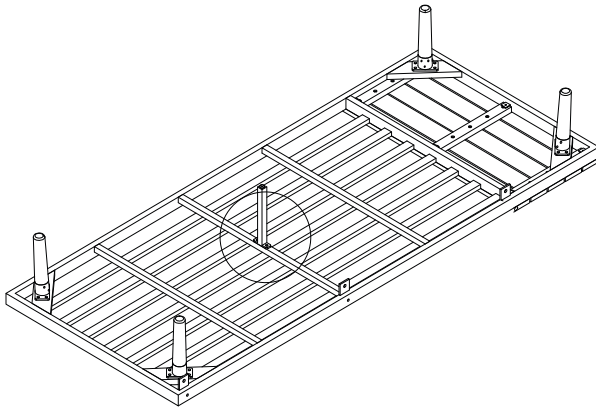

STEP 3

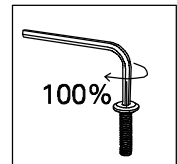
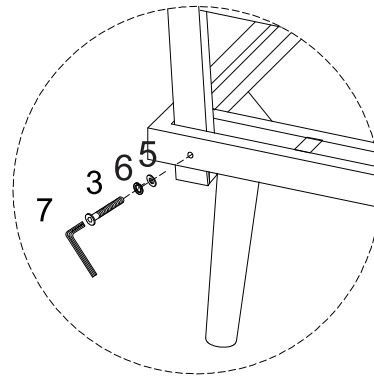
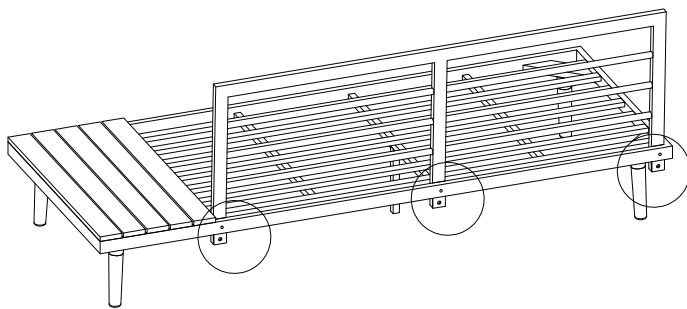

STEP 4

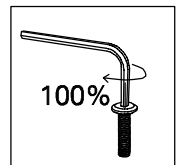
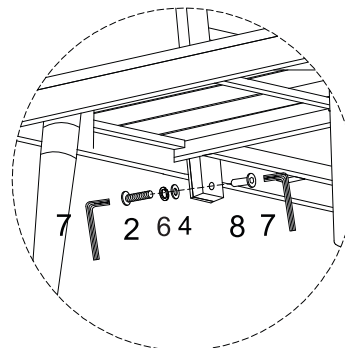
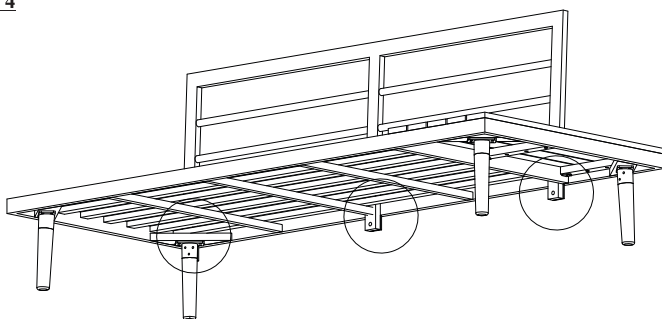

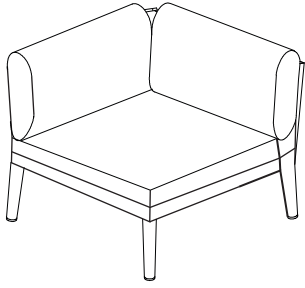



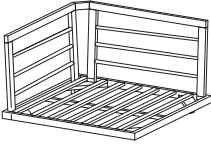
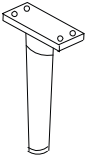

IMPORTANT NOTE:

- Place all parts on a clean and smooth surface such as a rug or carpet to avoid the parts from being scratched.
- Check to be sure that you have all parts and hardware.
- Remove all wrapping materials, including staples & packing
- Do not tighten all screws/bolts until all completely assembled.
- Keep all hardware parts out of reach of children.

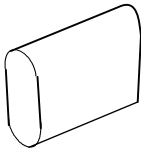
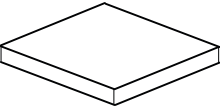
Corner Bench (C)

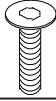
L724-CRTB	PART LIST		
	NO	DESCRIPTION	QTY
	D	 Corner Bench	1 PC
	F	 Leg	4 PCS
	H	 Magic tape	4 PCS
	J	 Corner Bench Back Cushion	2 PCS
	L	 Corner Bench Cushion	1 PC

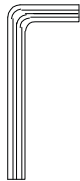
L724	PART LIST		
	NO	DESCRIPTION	QTY
	1	 JCBC Bolt M6x15	16 PCS
	4	 Flat Washer M6x16	16 PCS
	6	 Spring Washer M6x13	16 PCS
	7	 Allen Key	1 PC

STEP 1

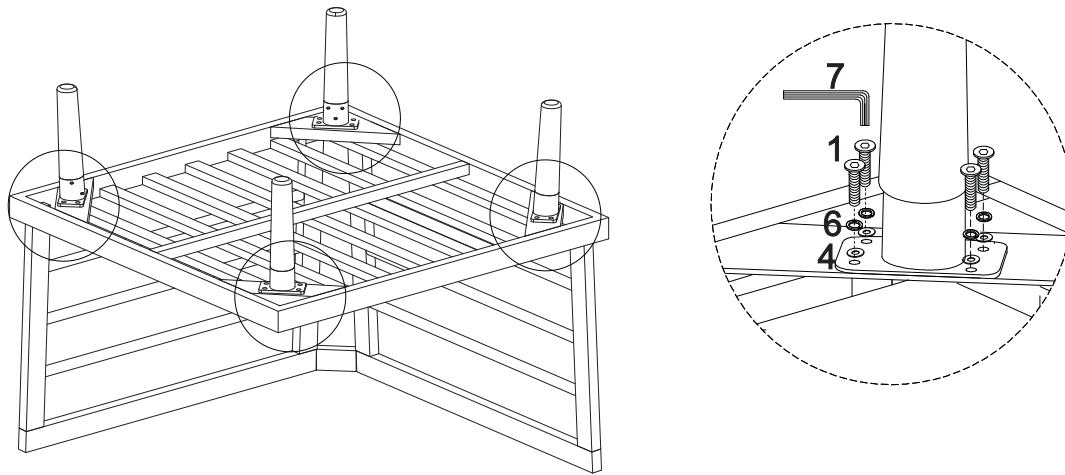

STEP 2

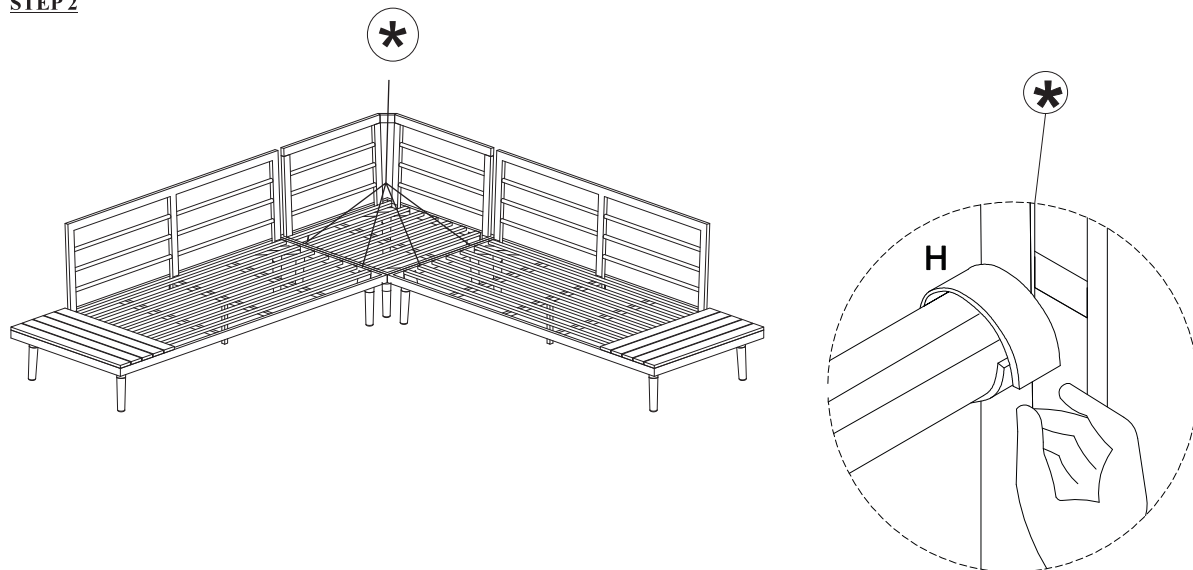

STEP 3

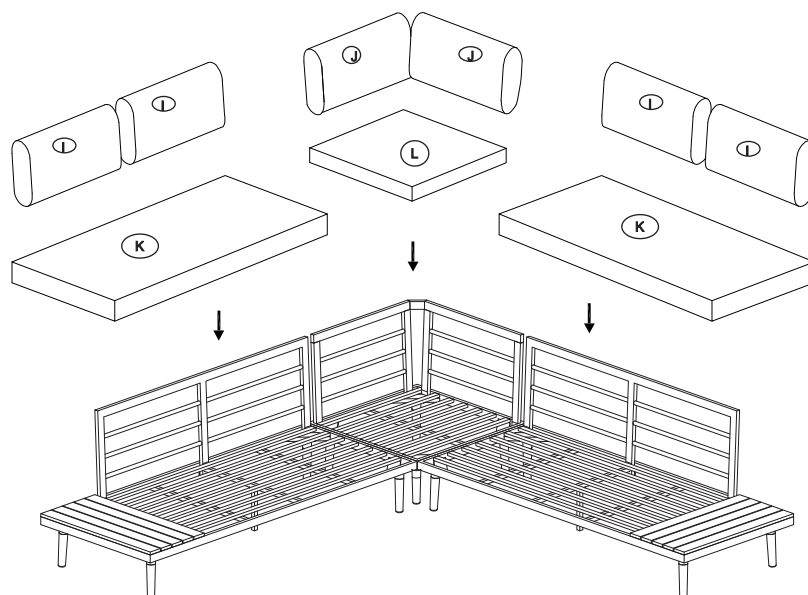

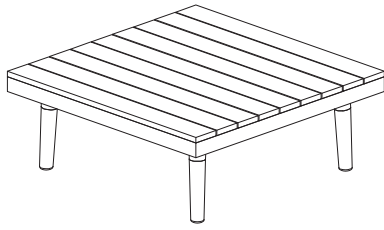



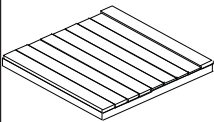
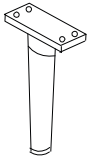

IMPORTANT NOTE:

- Place all parts on a clean and smooth surface such as a rug or carpet to avoid the parts from being scratched.
- Check to be sure that you have all parts and hardware.
- Remove all wrapping materials, including staples & packing
- Do not tighten all screws/bolts until all completely assembled.
- Keep all hardware parts out of reach of children.

Table

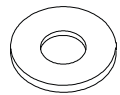
L724-CRTB	PART LIST		
	NO	DESCRIPTION	QTY
E		Table top	1 PC
F		Leg	4 PCS

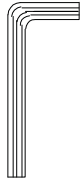
L724	PART LIST		
	NO	DESCRIPTION	QTY
1		JCBC Bolt M6x15	16 PCS
4		Flat Washer M6x16	16 PCS
6		Spring Washer M6x13	16 PCS
7		Allen Key	1 PC

STEP 1:

