











Parker House  
FURNITURE

# Assembly Instruction

Item NO. SH0#498D-EFW/ SH0#498D-MDR

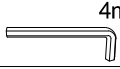
## Part List

No.	Description	Q'ty
#1	Middle Desk Top	1
#2	Left Desk Top	1
#3	Right Desk Top	1
#4	Side Frame	2
#5	Back Leg	2

Hardware bag			1SET
A	Bolt	$\varnothing 1/4" \times 32\text{mmL}$ 	34PCS
B	Lock washer	$1/4" \times \varnothing 13\text{mm}$ 	34PCS
C	Flat washer	$1/4" \times \varnothing 16\text{mm}$ 	34PCS
D	Allen Wrench	4mm 	1PC
E	Wood dowel	$\varnothing 8 \times 30\text{mm}$ 	8PCS
F	Desk Grommet		1PC
G	Touch Up Pen		1PC

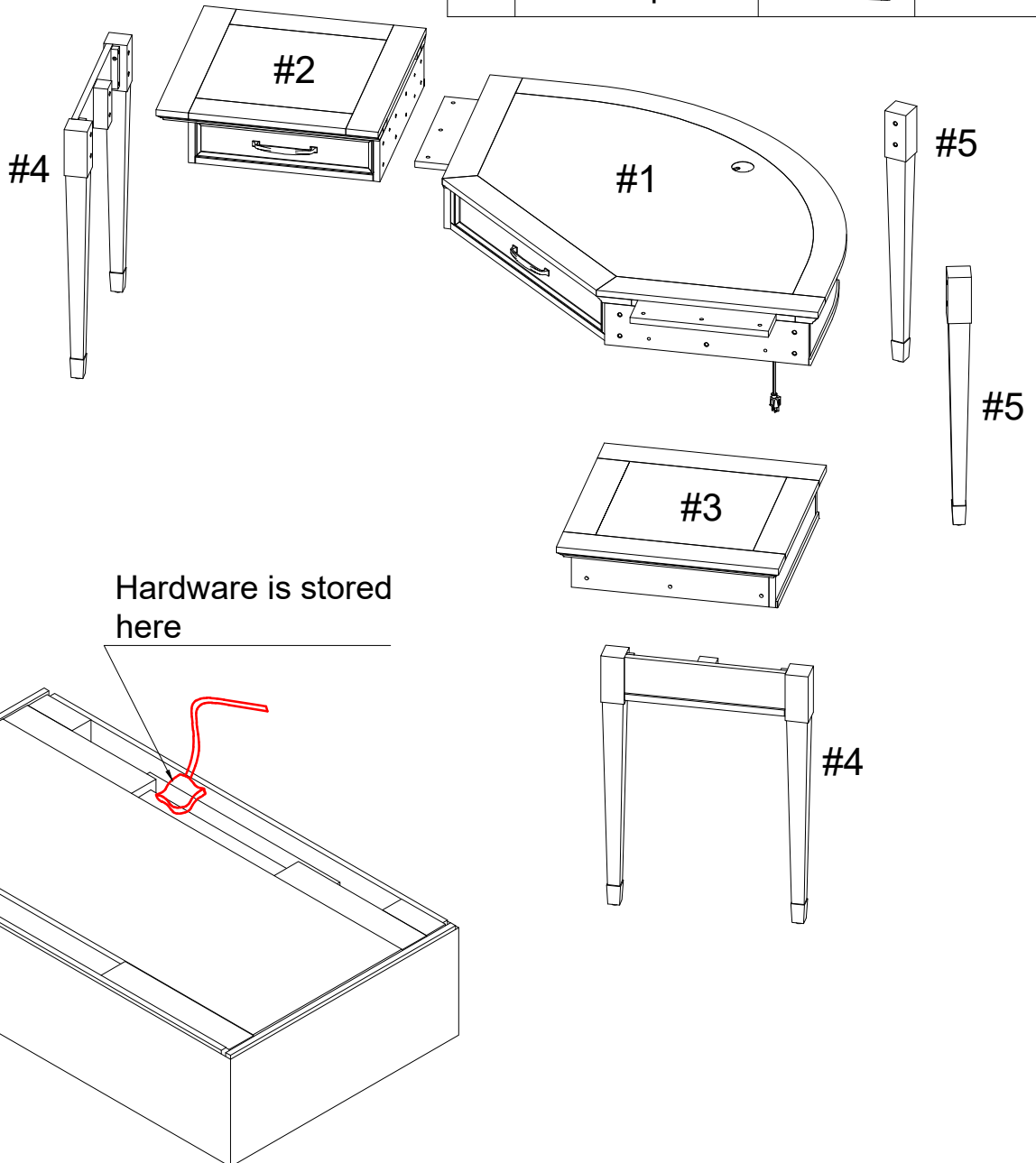



Parker House  
FURNITURE

# Assembly Instruction

Item NO. SH0#498D-EFW/ SH0#498D-MDR

## Step 1:

Replace the drawers. Press the tab down on the right side of the drawer and lift tab up on the left side of the drawer at the same time. Then pull drawer out another inch to disengage latch.

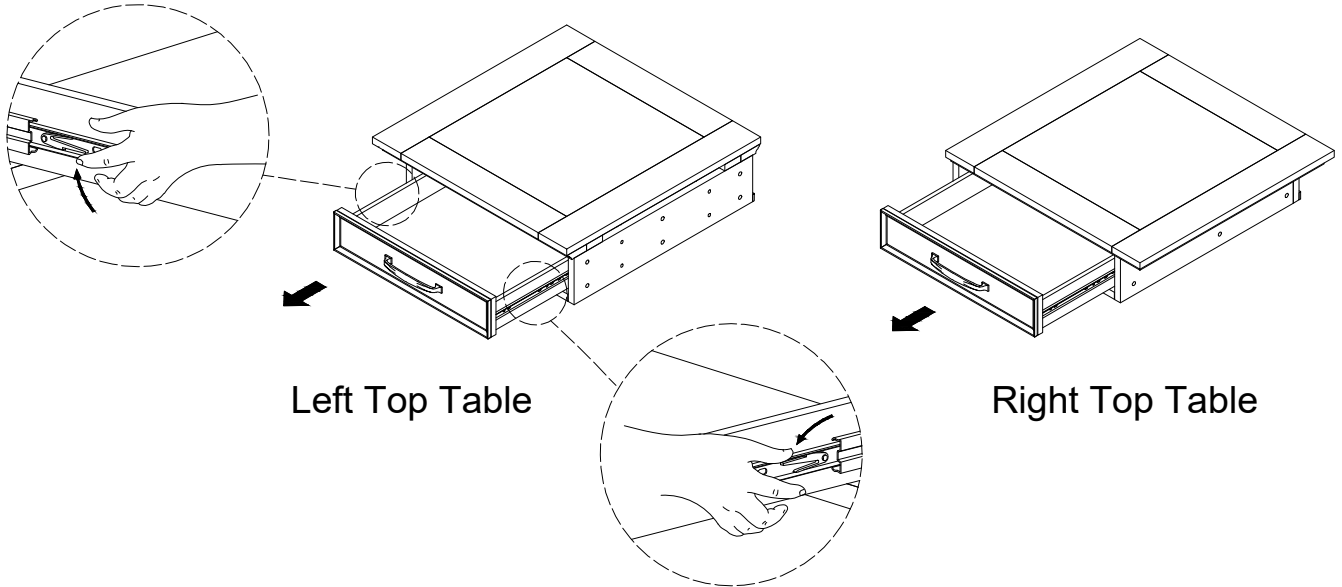

## Step 2:

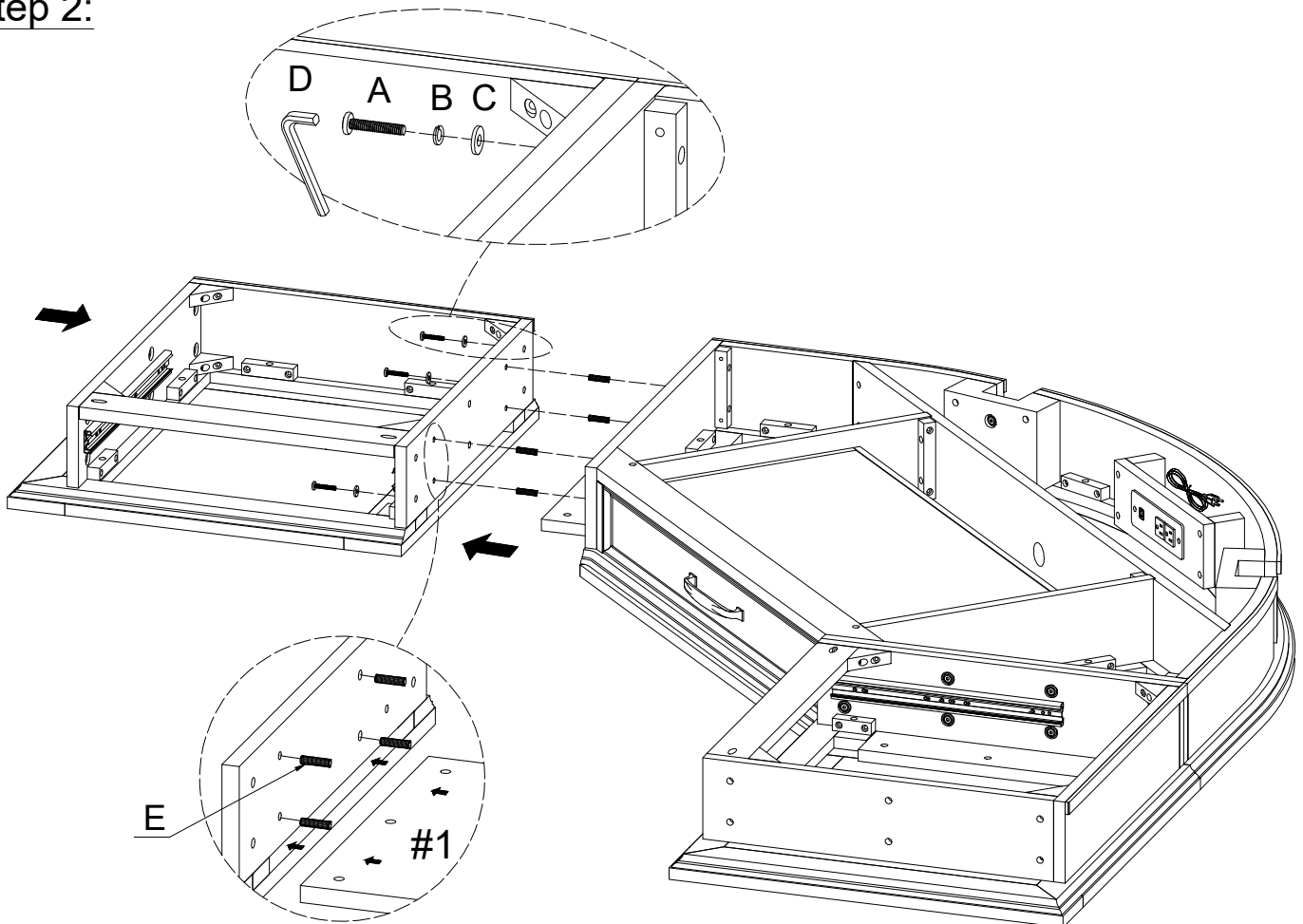



Parker House  
FURNITURE

# Assembly Instruction

Item NO. SH0#498D-EFW/ SH0#498D-MDR

## Step 3:

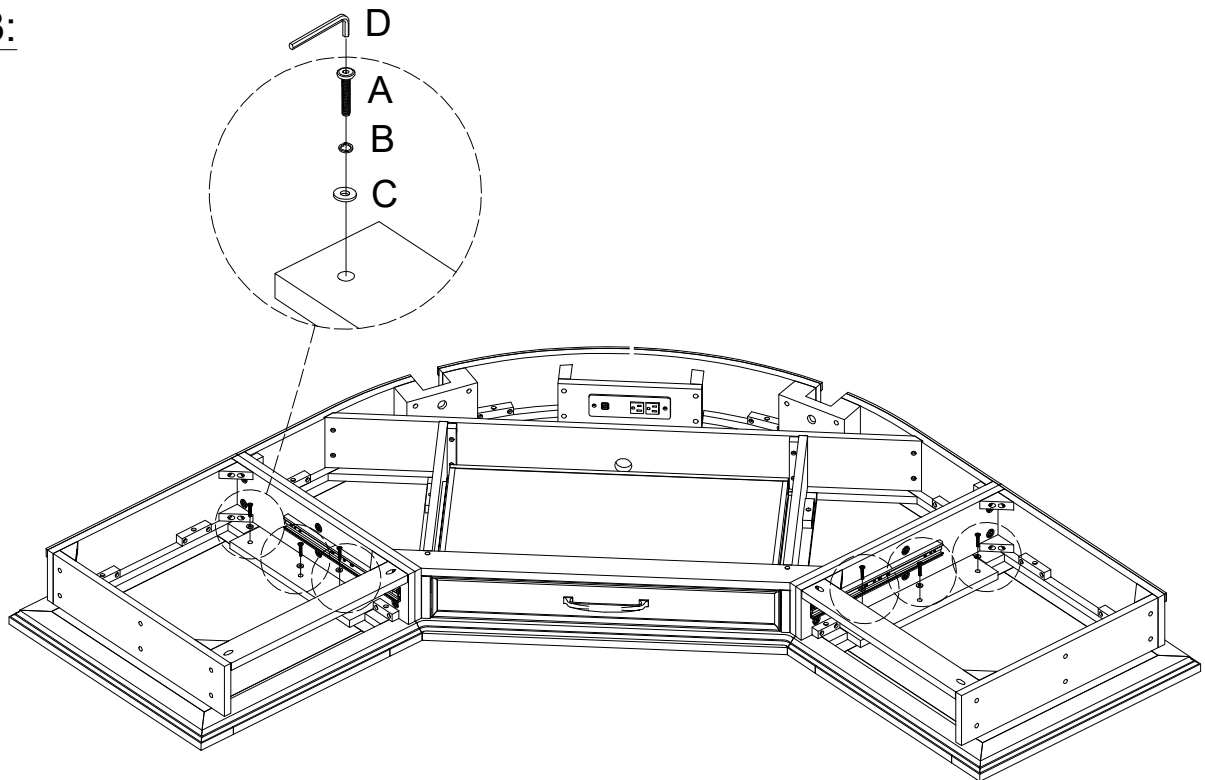

## Step 4:

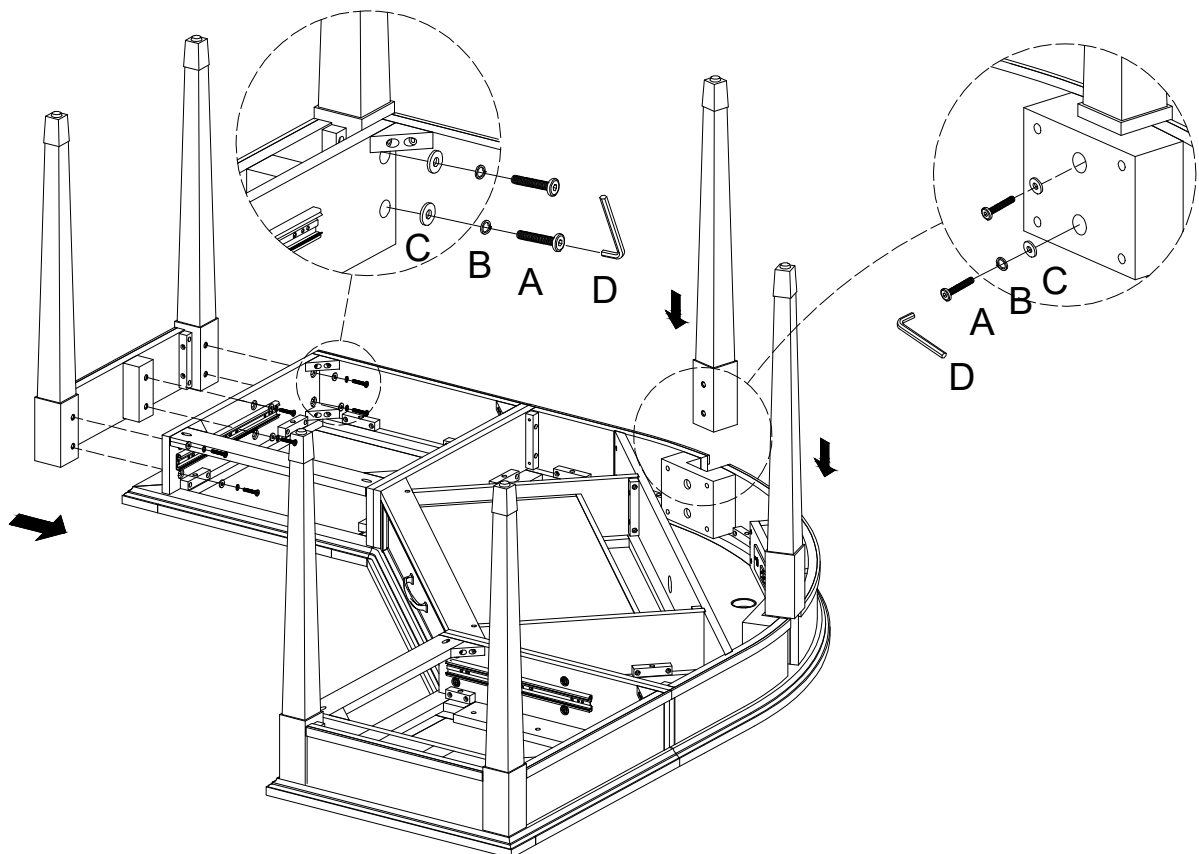



Parker House  
FURNITURE

# Assembly Instruction

Item NO. SH0#498D-EFW/ SH0#498D-MDR

## Step 5:

Replace the drawers. Align the drawer rails with the receiving slides. Push drawer in all the way. Gently open and close the drawer to ensure it is seated properly on the slides.

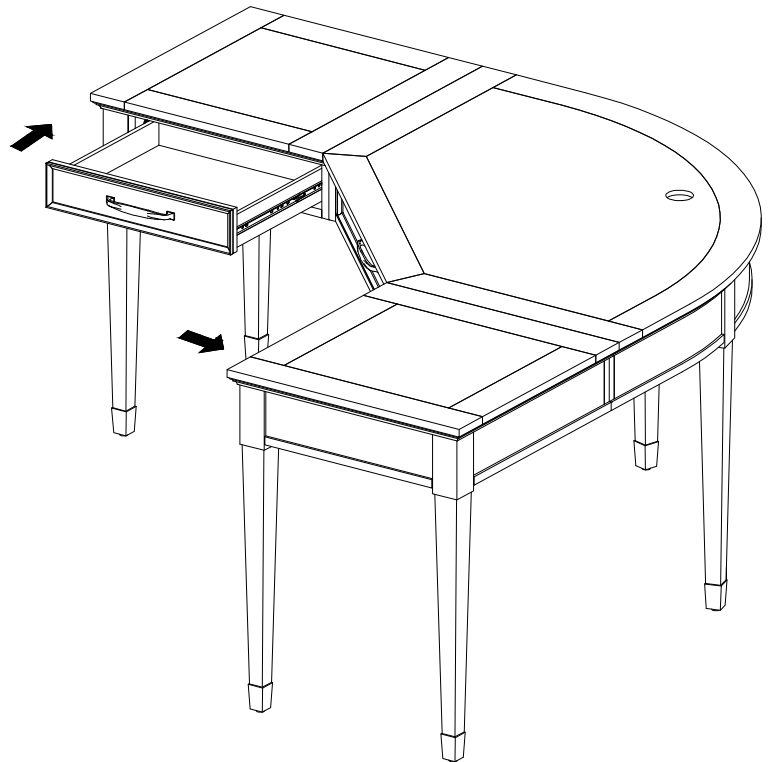

## Step 6:

