







**Parker House**  
FURNITURE

# Assembly Instruction

Item No: DAME#60RECT

Description : DINING TABLE 60IN X 38IN. RECT TO 78IN

## HARDWARE LIST

No	Description	Sketch	Q'TY
A	Allen Wrench 4mm		1PC
B	Bolt Ø5/16 x 70mm		8PCS
C	Lock Washer Ø5/16x12mm		8PCS
D	Flat Washer Ø5/16x19mm		8PCS

## PARTS LIST

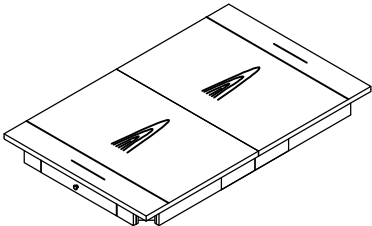
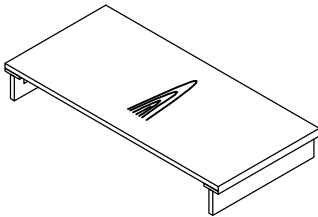
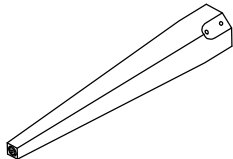
TABLE TOP (1PC)	LEAF (1PC)	LEG (4PCS)
① 	② 	③ 

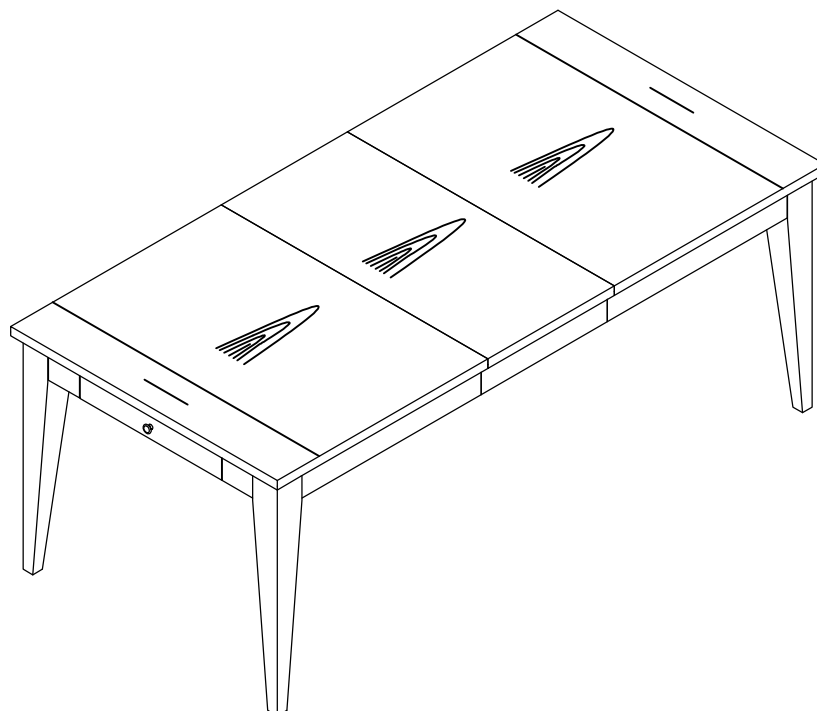



Parker House  
FURNITURE

# Assembly Instruction

Item No: DAME#60RECT

Description : DINING TABLE 60IN X 38IN. RECT TO 78IN

STEP 1

Hardware are here

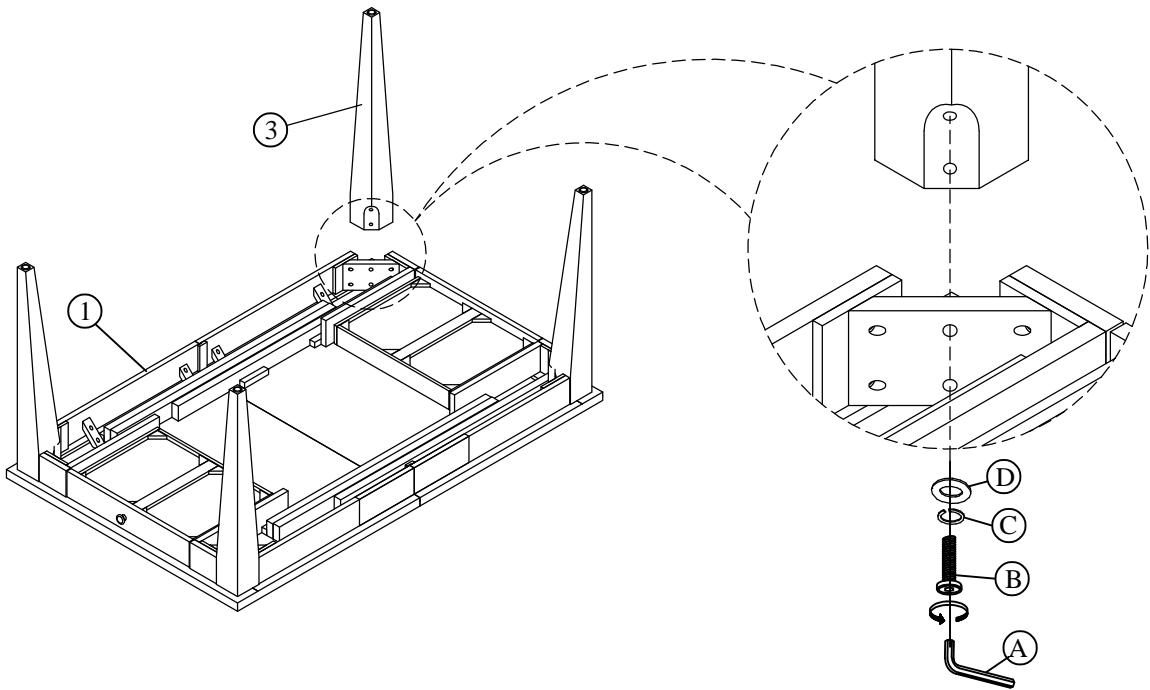
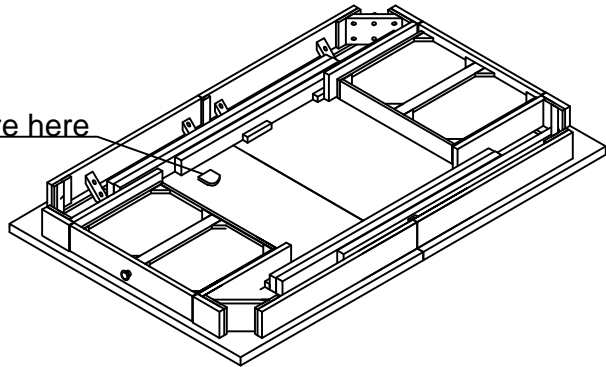

STEP 2

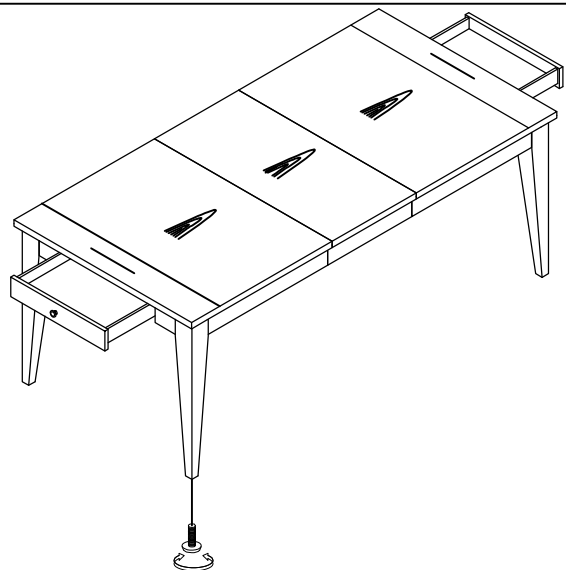
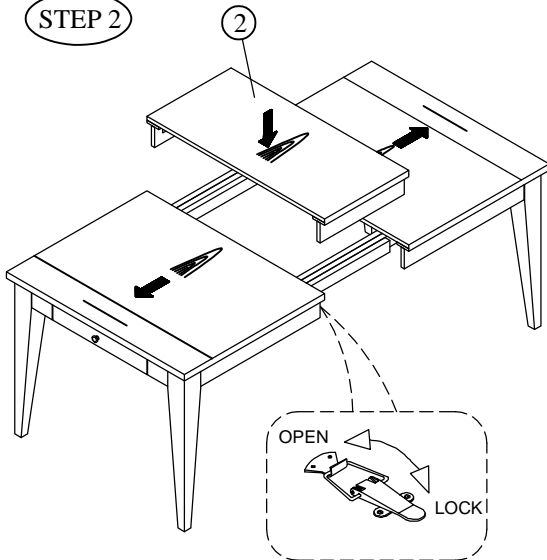

LEVELER =4PCS