



Parker House®  
FURNITURE





# Assembly Instruction

Item No: AME#02

Description : END TABLE

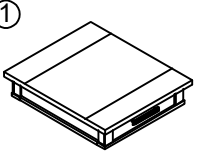
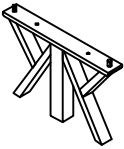
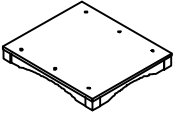
## HARDWARE LIST

## PARTS LIST

No	Description	Sketch	Q'TY	TABLE TOP (1PC)	LEG FRAME (2PCS)	TABLE BOTTOM (1PC)
A	Allen Wrench 4mm		1PC			
B	Bolt (Ø5/16"x1-1/2")		10PCS			
C	Spring Washer Ø5/16"		10PCS			
D	Flat Washer Ø5/16x19mm		10PCS			

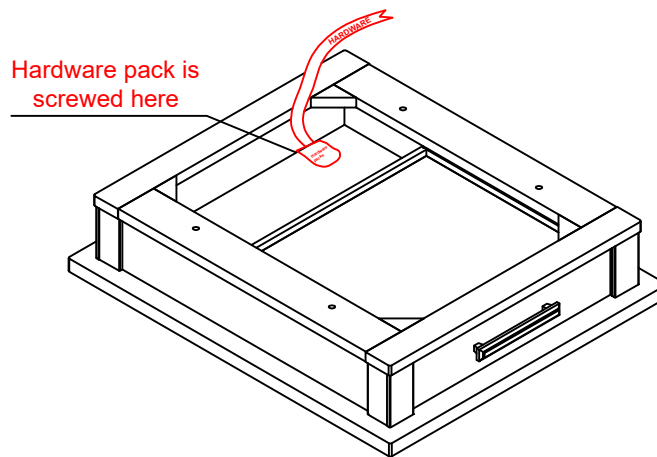
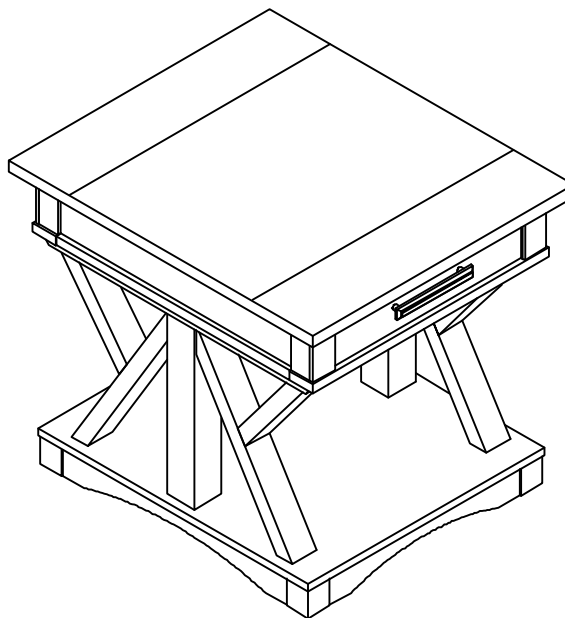



Parker House<sup>®</sup>  
FURNITURE

# Assembly Instruction

Item No: AME#02

Description : END TABLE

STEP 1

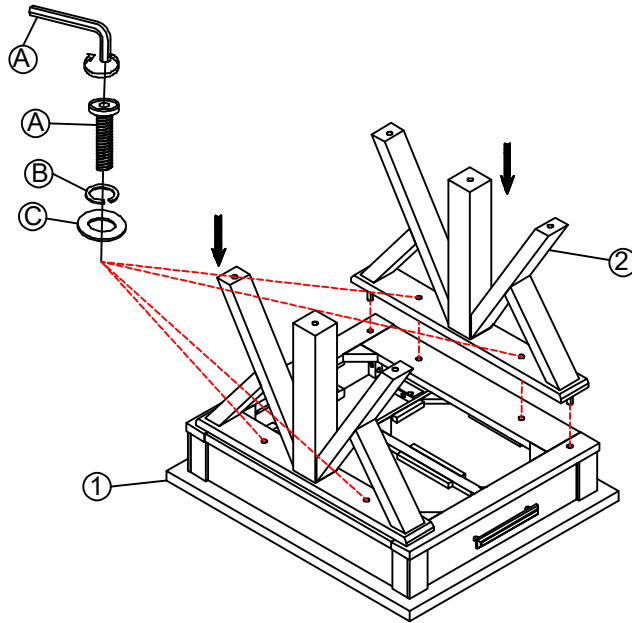

STEP 2

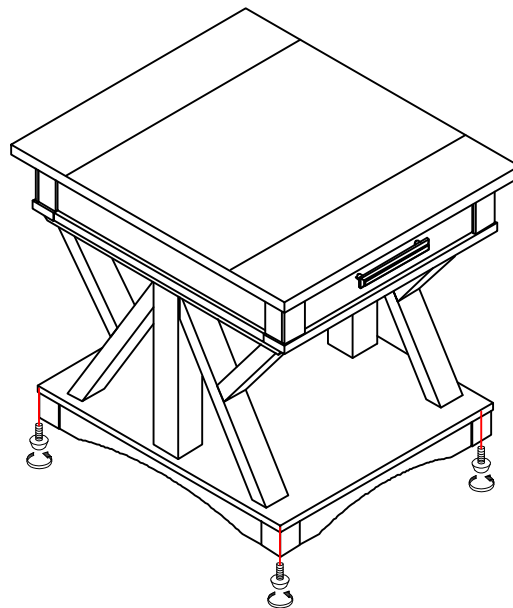
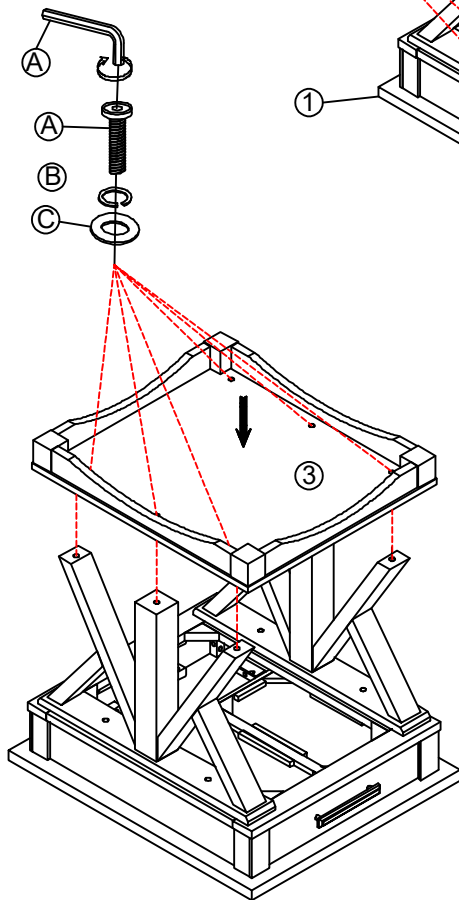

Assembled  
leveler =4PCS