

**Café Time Adjustable Height Table**  
**Assembly instructions**

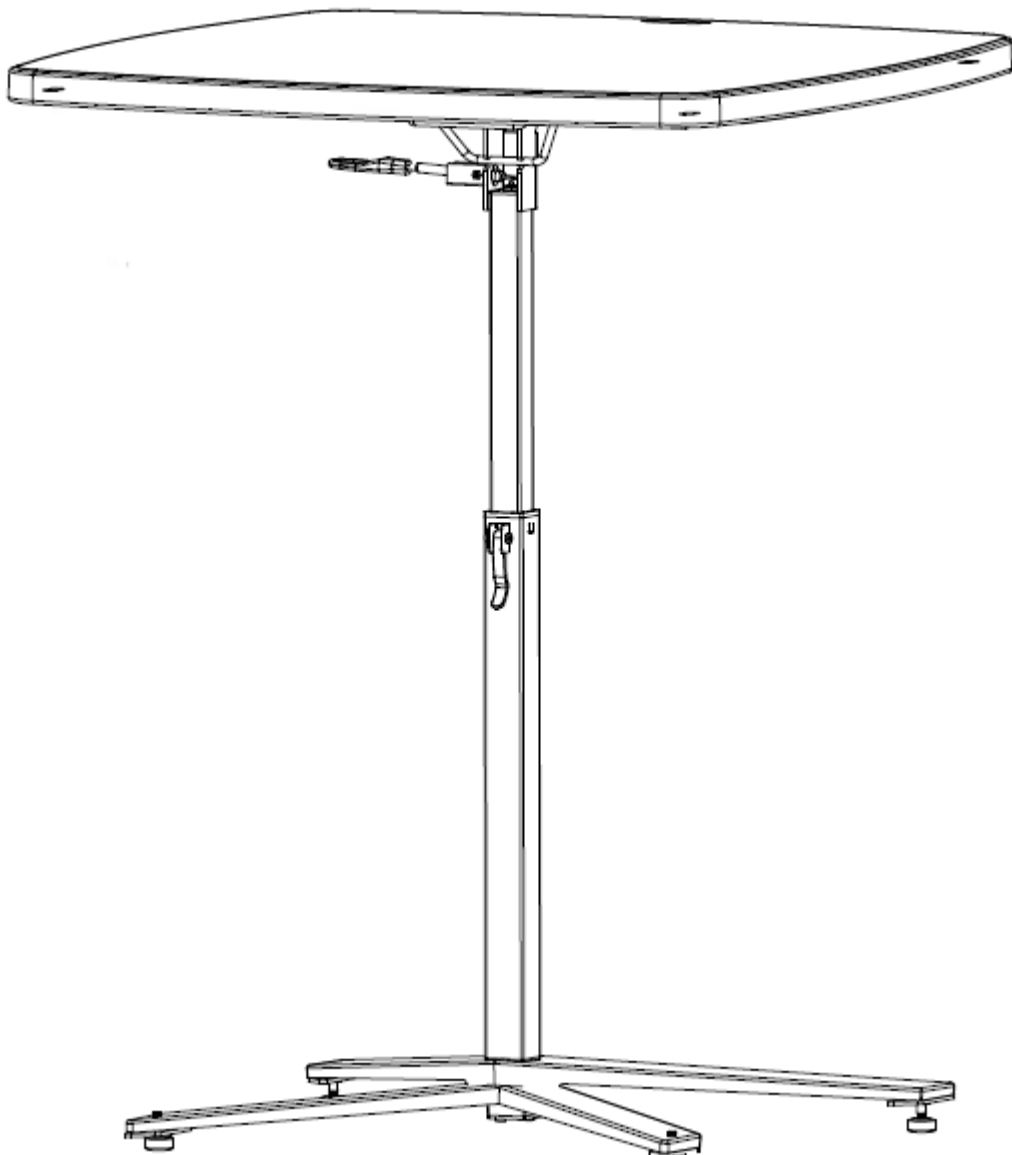

**Model # CTT3042**

Begin by identifying all the parts and hardware.

| Part Number | (A)  | (B)    | (C)      | (D)            | (E)     | (F)        | (G)        | (H)    | (I)    | (J)       | (K)             | (L)     |
|-------------|------|--------|----------|----------------|---------|------------|------------|--------|--------|-----------|-----------------|---------|
| Sketch      |      |        |          |                |         |            |            |        |        |           |                 |         |
| Description | Base | Column | Tabletop | Plastic spacer | Bracket | M6x15 Bolt | M6x30 Bolt | Washer | Washer | Allen Key | Leveling Glides | Casters |
| Quantity    | 1    | 1      | 1        | 2              | 2       | 4          | 2          | 4      | 2      | 1         | 4               | 4       |

**Assembling column to base:**

**Step 1:** Remove base (Part A) from carton and place on clean flat surface.

**Step 2:** Insert bottom of column (Part B) firmly into center of base with column locking mechanism facing point at center of base. (See ILL. 1.).

**Step 3:** Carefully turn unit on its side to enable securing base to column.

**Step 4:** Place washers (Part I) on long bolts (part G) and using the provided Allen key (Part J), fasten the two bolts into column inserts to secure base to column making sure to tighten well. (See ILL. 2.).

**Step 5:** Screw on the four Leveling Glides (Part K) or the four Casters (Part L) to the four corners of underside of base.

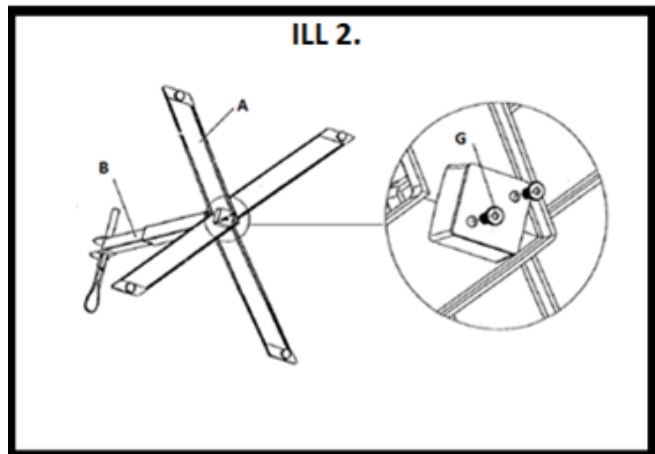
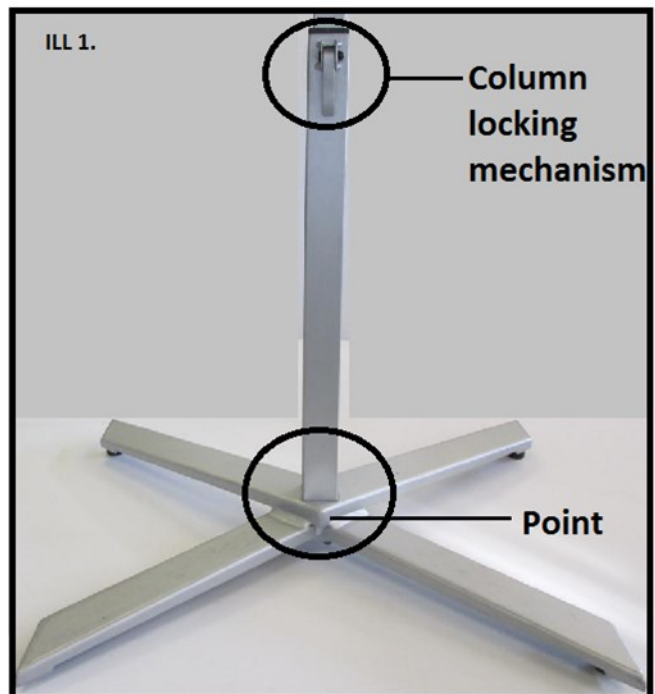

**Assembling tabletop to column:** (Note: Two people are needed for this).

**Step 1:** After column has been installed onto base, lift unit and place in standing position.

**Step 2:** Carefully remove tabletop from carton and have one person place it vertically onto column (See ILL 3A.) by placing latch into notch on top of column as illustrated (ILL 3B.) and hold in place while second person completes attachment.

**Step 3:** While tabletop is being held, plastic spacers (part D) should be placed onto bottom rod in between bolt holes (See ILL. 4)

**Step 4:** Place brackets Part (E) over spacers and align with inserts on center tabletop tubes. (See ILL 5.)

**Step 5:** Place washers (Part H) on short bolts (Part F) and using the provided Allen key, fasten the four bolts into the inserts on center tabletop tubes making sure to tighten well.

**Step 6:** Once table is completely assembled, adjust leveling glides as needed.

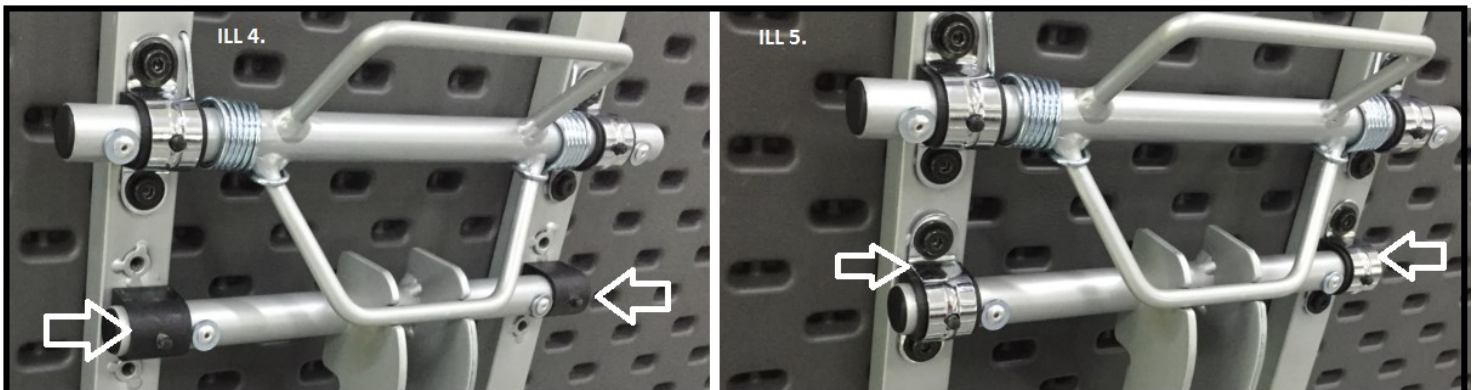
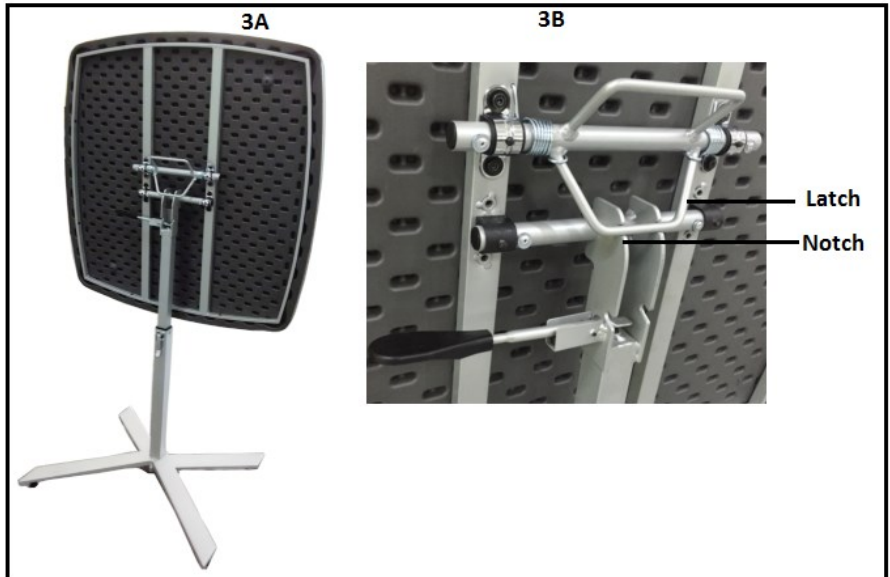

Dear Customer,

Thank you for your purchase. Although extreme care goes into the manufacturing and packaging of this product, mistakes are possible. If you encounter any missing parts or difficulty in assembly, please call our customer service **TOLL FREE at 1-800-261-4112** for a courteous and immediate resolution to your problem.