

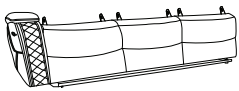







Thank you for purchasing this quality product. Be sure to check all packing materials carefully for small parts, which may have come loose during shipment. Identify and count all items and compare with the parts list shown below. It is recommended to have two people during assembling and to remove the back and base of the furniture out from the box .

Please follow the drawings below to assemble the item

PARTS LIST

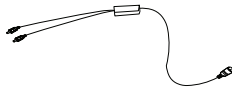
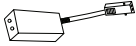
NO.	DESCRIPTION	SKETCH	QTY
A	Seat		1PC
B	Left Backrest		1PC
C	Mid Backrest		1PC
D	Right Backrest		1PC
E	Left Wing		1PC
F	Round End Power Cable		1PC
G	Two-one circle power connector		1PC
H	Transformer		1PC
I	Power connector		1PC

STEP 1: Insert the KD backrests (B), (C), (D) to the seat (A) and make sure the backrests are secured in position

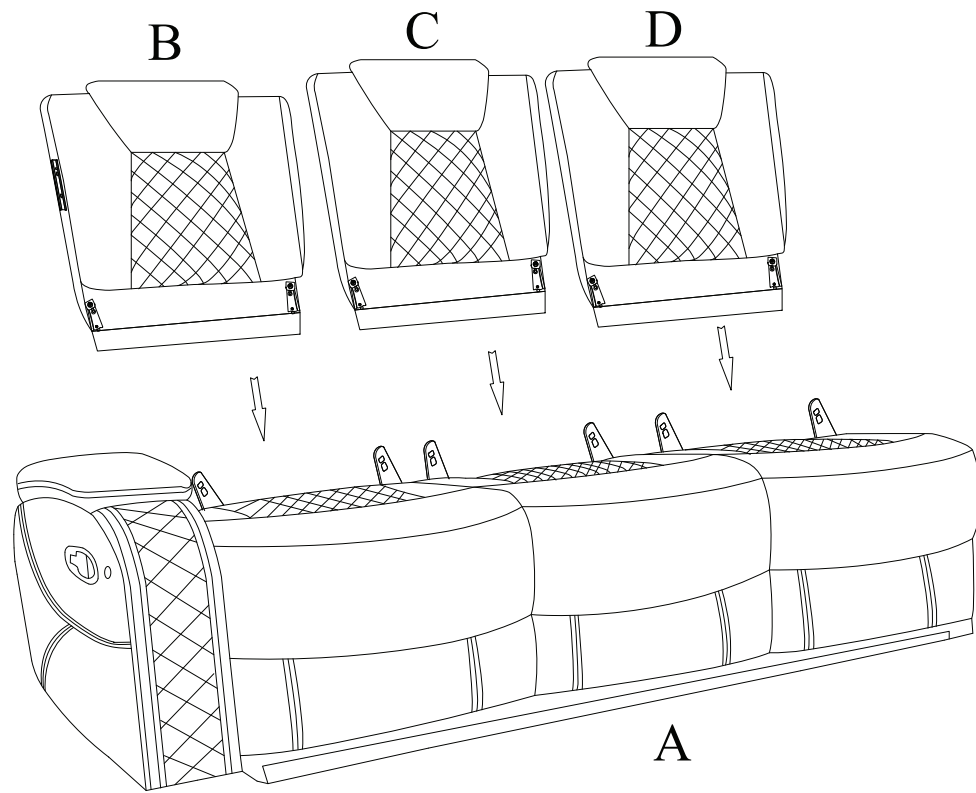

STEP 2: Insert the handrails (E) into the backrest (B) and make sure it is secured in position

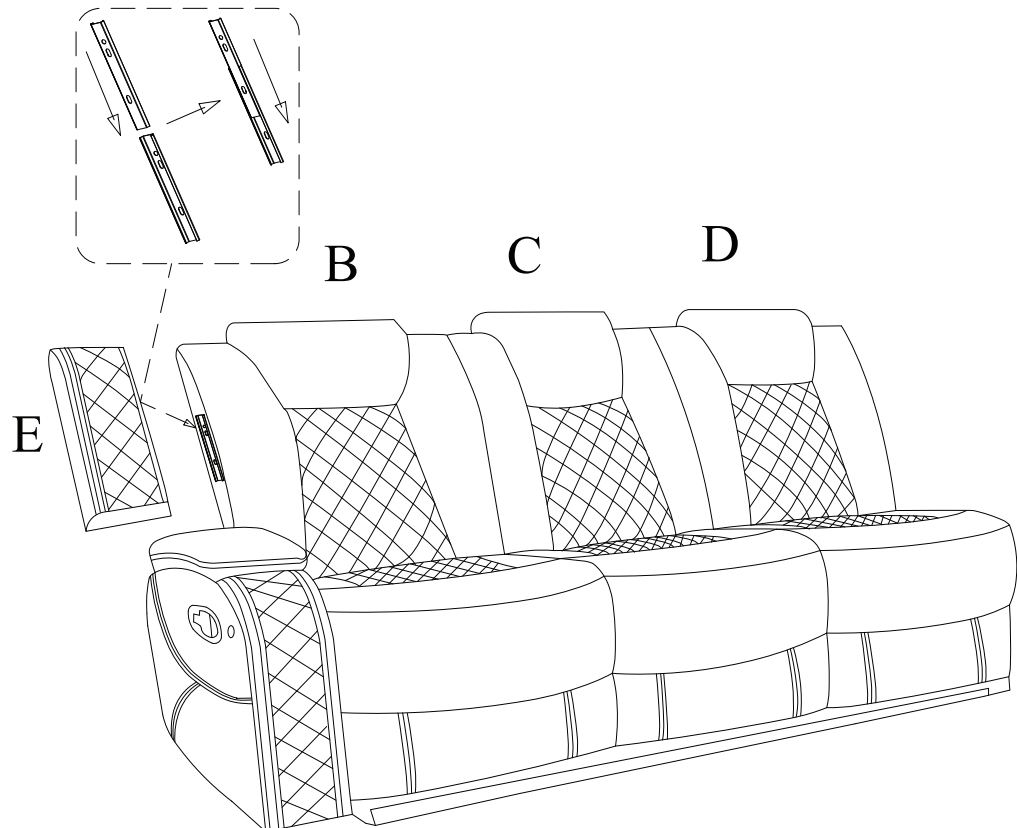

STEP 4: Find the electric motor cable which is fasted to the metal frame of the seat. Connect the two-one circle power connector (G) to the electric motor cable. In the other side, plug the power connector (I) to the transformer (H), then connect the transformer (H) to the seat's cable.

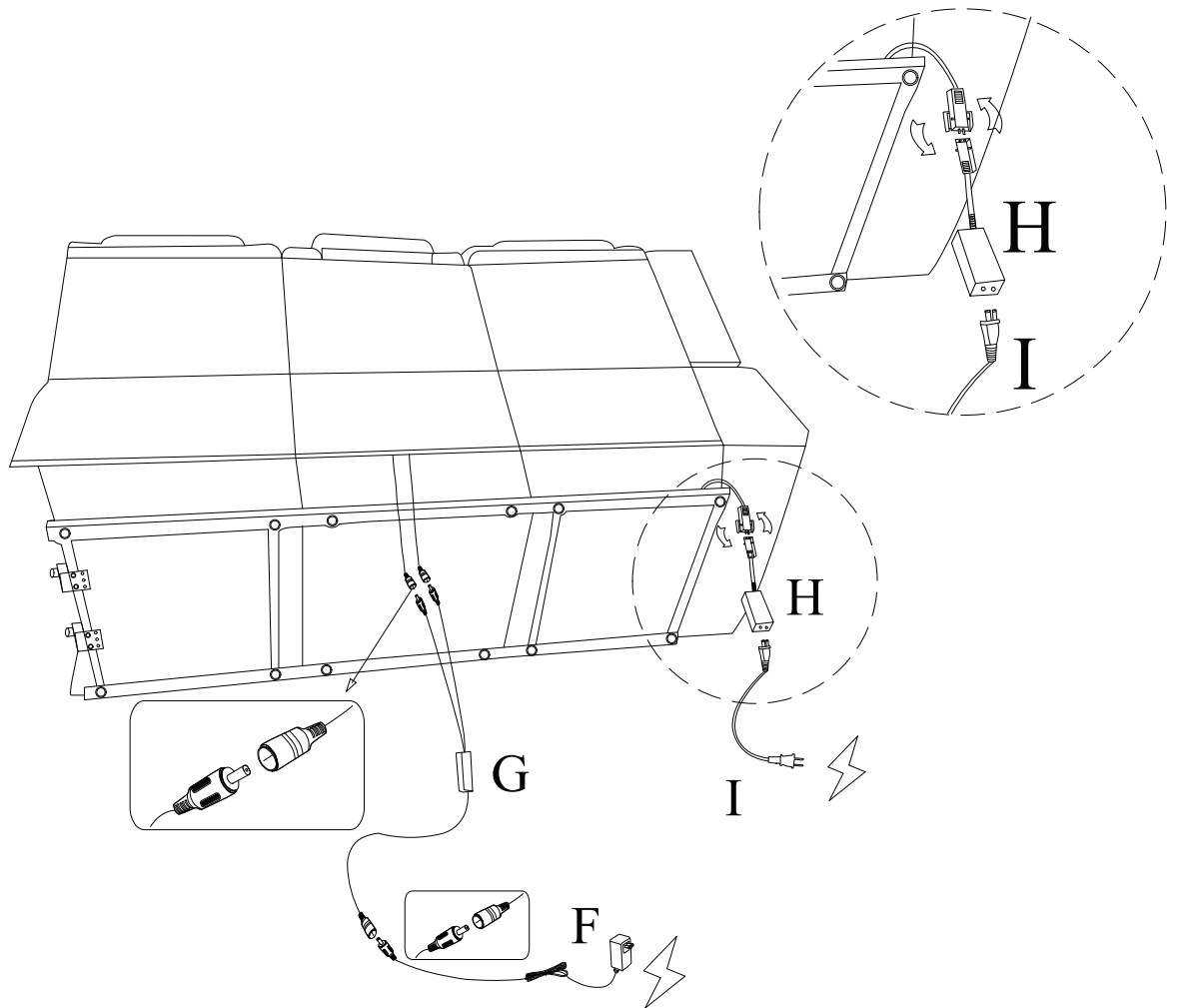

STEP 5: Completed as picture below

