



Assembly Instructions

ITEM NO. D5524-50S
 FLAIR 60" DINING TABLE + 4 CHAIRS
 (5 PCS/CTN)

Thank you for purchasing this quality product. Be sure to check all packing materials carefully for small parts, which may have come loose inside the carton during shipment. Identify and count all items and compare with the PARTS LIST and/or HARDWARE LIST shown below.



Please read the instructions thoroughly before assembly.

1. We recommend that you assemble this product with the assistance of another person; this will make the assembly easier, and will help eliminate damage to the product or injury to persons during assembly.
2. Please do not tighten screws or bolts until the assembly is completed.
3. To level the chairs or table, before tightening all the screws, the chairs or table must be placed on a flat surface and then tighten the screws.
4. Please put all parts on a non-abrasive floor before assembly and follow the assembly steps to assemble your newly purchased product correctly and efficiently.

PARTS LIST

NO.	COMPONENT	SKETCH	QTY
A	CHAIR BACK		4PCS
B	SEAT		4PCS
C1	RIGHT SIDE FACING (RSF) LEG		4PCS
C2	LEFT SIDE FACING (LSF) LEG		4PCS
D1	RIGHT SIDE FACING (RSF) STRETCHER		4PCS
D2	LEFT SIDE FACING (LSF) STRETCHER		4PCS

HARWARE LIST

NO.	COMPONENT	SKETCH	QTY
1	FLAT WASHER 1/4" DIA.		44 PCS
2	SPRING WASHER 1/4" DIA.		44 PCS
3	SHORT BOLT 1/4" x 1 9/16"		12 PCS
4	MEDIUM BOLT 1/4" x 2 3/8"		16 PCS
5	LONG BOLT 1/4" x 3"		16 PCS
6	ALLEN WRENCH (4mm)"		1 PC
7	WOOD SCREW 1/4" x 1 9/16"		16 PCS

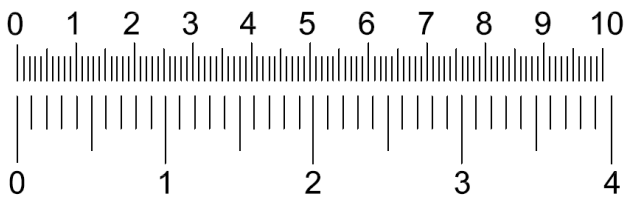

Assembly Instructions

ITEM NO. D5524-50S
FLAIR 60" DINING TABLE + 4 CHAIRS
(5 PCS/CTN)

STEP 1

Place the chair back (A) on a soft and clean surface.
Assemble the seat (B) with the chair back (A) by using Allen Wrench (6) with hardware 1, 2, and 3. Then assemble the seat (B) with the back legs of the chair back (A) using Allen Wrench (6) with hardware 1, 2, and 5.
*Attention: DO NOT TIGHTEN THE BOLTS.

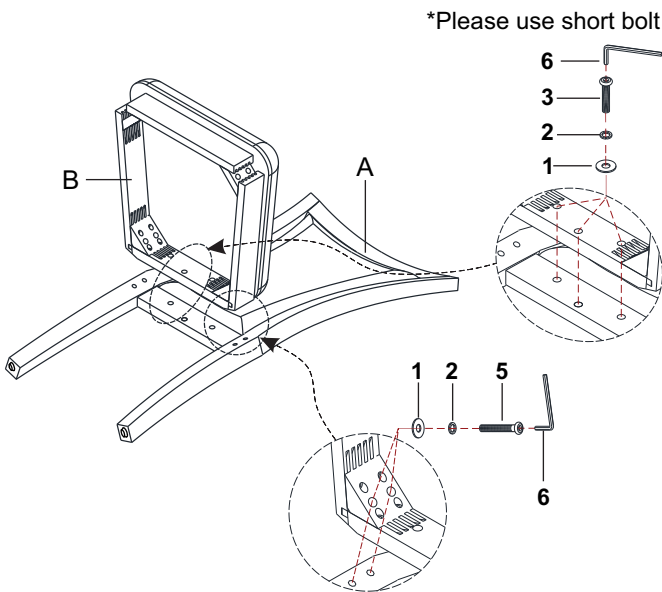

STEP 2

Assemble the front legs (C1) and (C2) with the seat (B) by using Allen Wrench (6) with hardware 1, 2, and 4.
*Attention: DO NOT TIGHTEN THE BOLTS

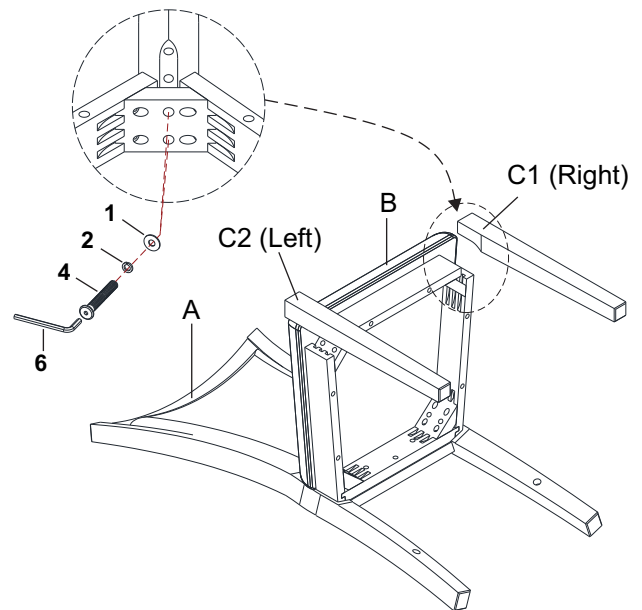

STEP 3

Install both RSF Stretcher (D1) and LSF Stretcher (D2) to chair back (A) and front legs (C1) and (C2) by using a screw driver with hardware 7.
*Attention: DO NOT TIGHTEN THE SCREWS

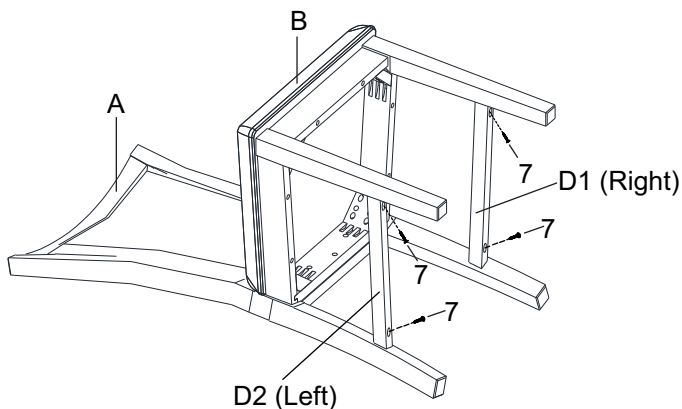

STEP 4

To level the chair, stand the chair up on a flat surface and tighten all the bolts by using Allen Wrench (6) and tighten all the screws by using a screw driver.

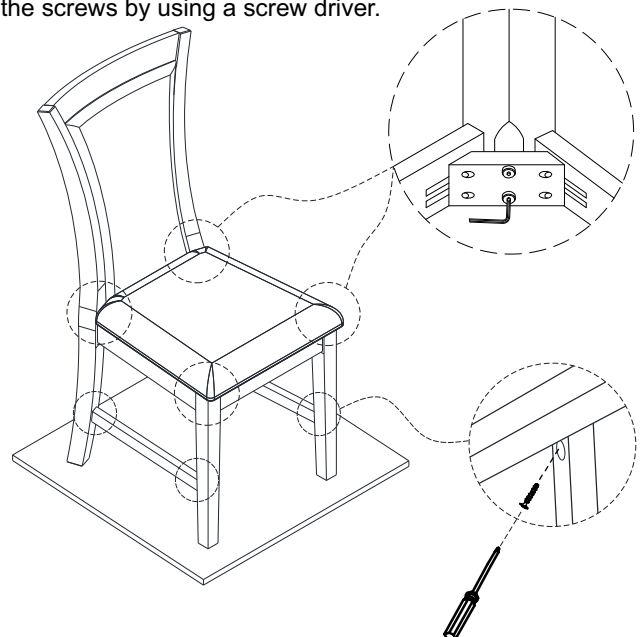



Assembly Instructions

ITEM NO. D5524-50S
FLAIR 60" DINING TABLE + 4 CHAIRS
(5 PCS/CTN)

STEP 5

Repeat STEP 1 through STEP 4 to assemble the other chairs.

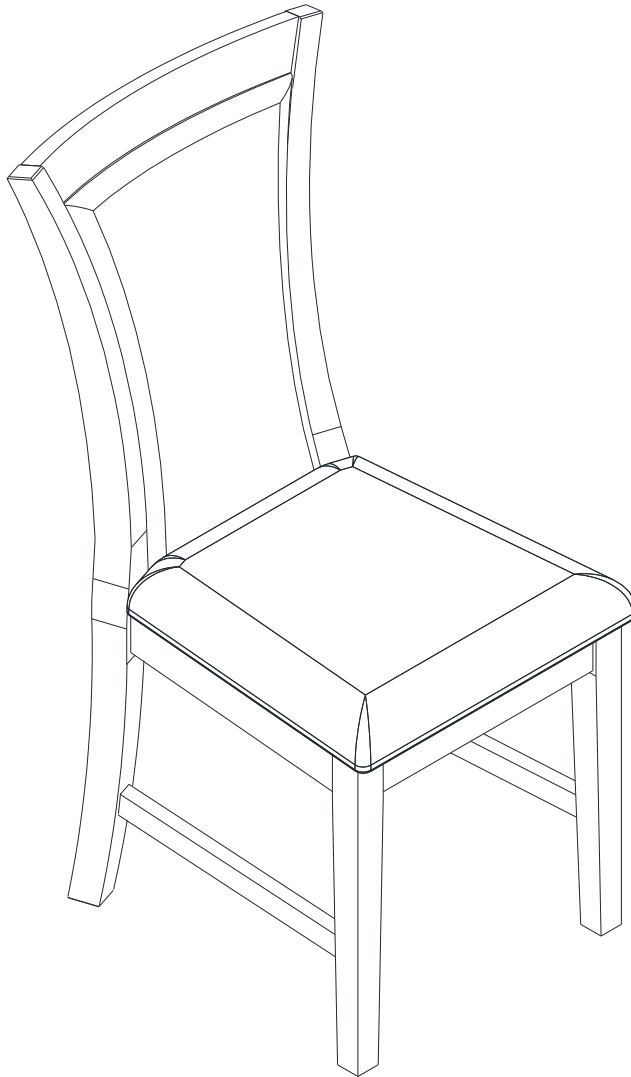

Fully Assembled Chair



Assembly Instructions

ITEM NO. D5524-50S
 FLAIR 60" DINING TABLE + 4 CHAIRS
 (5 PCS/CTN)

Thank you for purchasing this quality product. Be sure to check all packing materials carefully for small parts, which may have come loose inside the carton during shipment. Identify and count all items and compare with the PARTS LIST and/or HARDWARE LIST shown below.





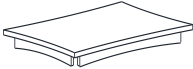
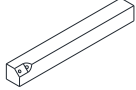

Please read the instructions thoroughly before assembly.

1. We recommend that you assemble this product with the assistance of another person; this will make the assembly easier, and will help eliminate damage to the product or injury to persons during assembly.
2. Please do not tighten screws or bolts until the assembly is completed.
3. To level the chairs or table, before tightening all the screws, the chairs or table must be placed on a flat surface and then tighten the screws.
4. Please put all parts on a non-abrasive floor before assembly and follow the assembly steps to assemble your newly purchased product correctly and efficiently.

PARTS LIST

NO.	COMPONENT	SKETCH	QTY
A	TABLE TOP		1PC
B	LEG		4PCS

HARWARE LIST

NO.	COMPONENT	SKETCH	QTY
1	FLAT WASHER 5/16" DIA.		8 PCS
2	SPRING WASHER 5/16" DIA.		8 PCS
3	BOLT 5/16" x 2 1/4"		8 PCS
4	ALLEN WRENCH (4mm)"		1 PC

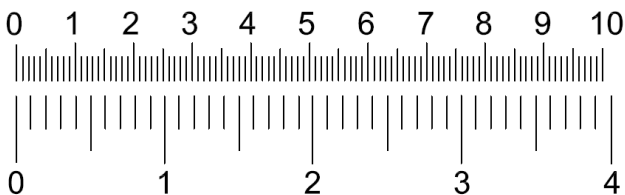

Assembly Instructions

ITEM NO. D5524-50S
FLAIR 60" DINING TABLE + 4 CHAIRS
(5 PCS/CTN)

STEP 1

Place the table top upside down on a soft and flat surface. Assemble table leg (B) by using Allen Wrench (4) with hardware 1, 2, and 3.

*Attention: DO NOT TIGHTEN THE BOLTS

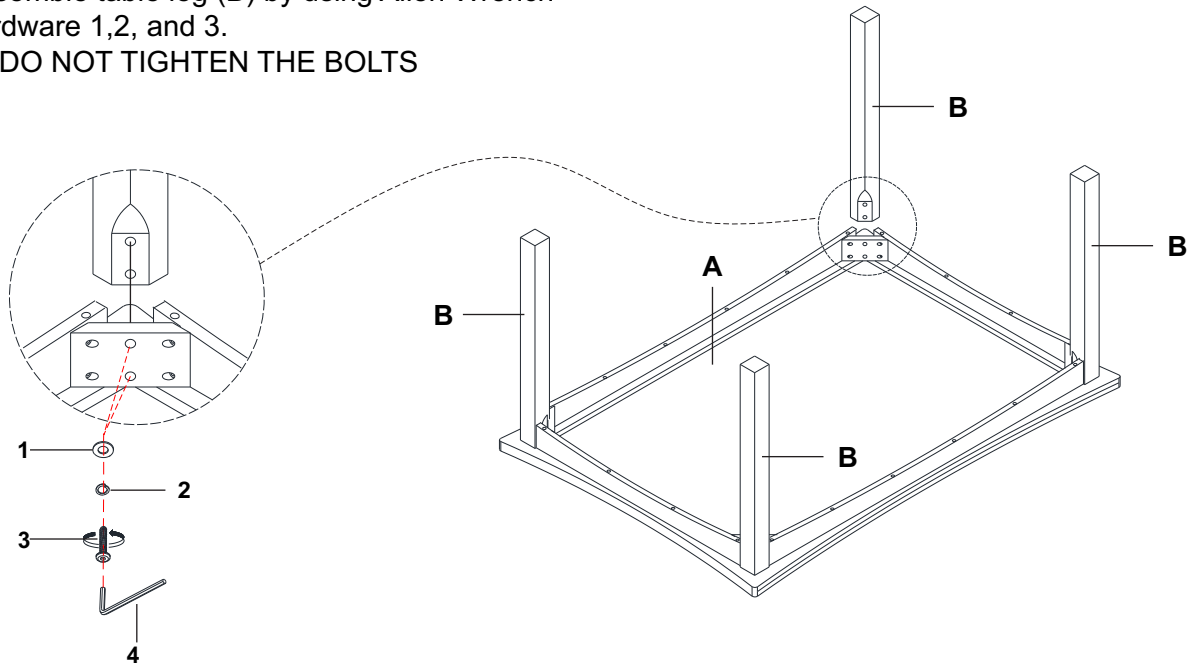

STEP 2

To level the table, stand the table up on a flat surface and tighten all the bolts by using Allen Wrench (4).

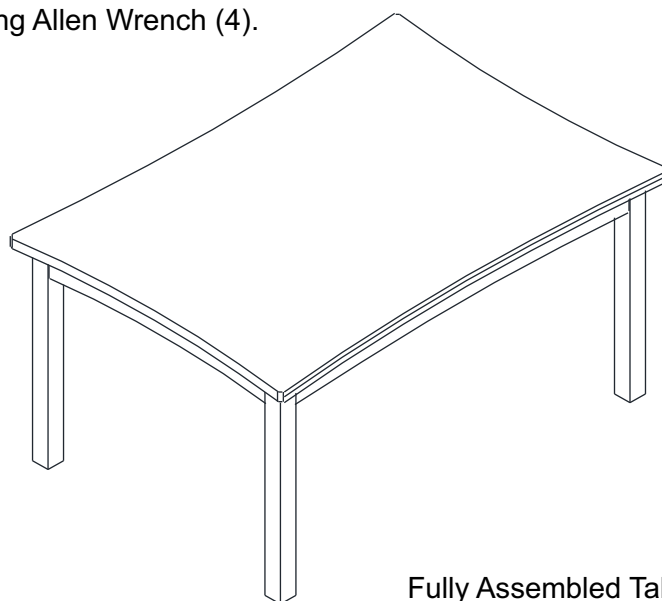

Fully Assembled Table