

Assembly Instructions

ITEM NO. D5398-11

ROUND DINING TABLE
(1 PC/CTN)



Thank you for purchasing this quality product. Be sure to check all packing materials carefully for small parts, which may have come loose inside the carton during shipment. Identify and count all items and compare with the PARTS LIST and/or HARDWARE LIST shown below.





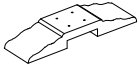
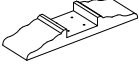

Please read the instructions thoroughly before assembly.

1. We recommend that you assemble this product with the assistance of another person; this will make the assembly easier, and will help eliminate damage to the product or injury to persons during assembly.
2. Please do not tighten screws or bolts until the assembly is completed.
3. To level the chairs or table, before tightening all the screws, the chairs or table must be placed on a flat surface and then tighten the screws.
4. Please put all parts on a non-abrasive floor before assembly and follow the assembly steps to assemble your newly purchased product correctly and efficiently.

PARTS LIST

NO.	COMPONENT	SKETCH	QTY
A	TABLE TOP		1 PC
B	MOUNTING PLATE		1 PC
C	LEGS		1 PC
D	UPPER BASE		1 PC
E	LOWER BASE		1 PC

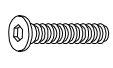
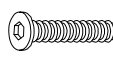
HARDWARE LIST

NO.	COMPONENT	SKETCH	QTY
1	FLAT WASHER 5/16" DIA.		12 PCS
2	SPRING WASHER 5/16" DIA.		12 PCS
3	BOLT 5/16" x 1 1/4"		4 PCS
4	BOLT 5/16" x 2"		4 PCS
5	BOLT 5/16" x 4 3/8"		4 PCS
6	ALLEN WRENCH (4mm)		1 PC

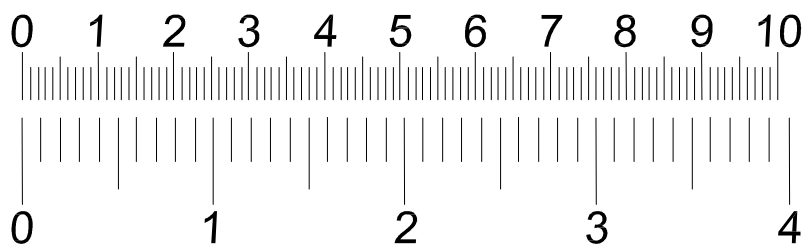

Assembly Instructions

ITEM NO. D5398-11

ROUND DINING TABLE
(1 PC/CTN)

STEP 1

Assemble the mounting plate (B) with the leg (C) using the Allen Wrench (6) with hardware 1,2 and 4.

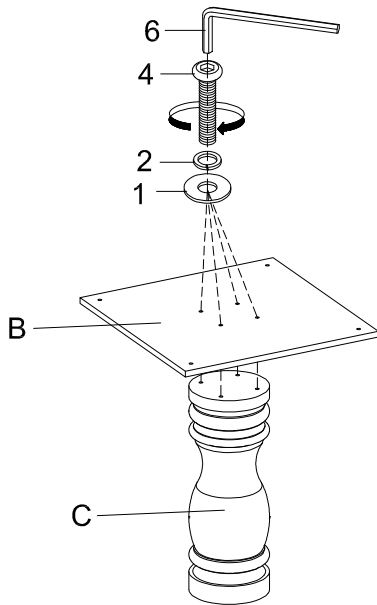

STEP 2

Assemble the legs (B) with the base (D), (E) by using Allen Wrench (6) with hardware 1,2, and 5.

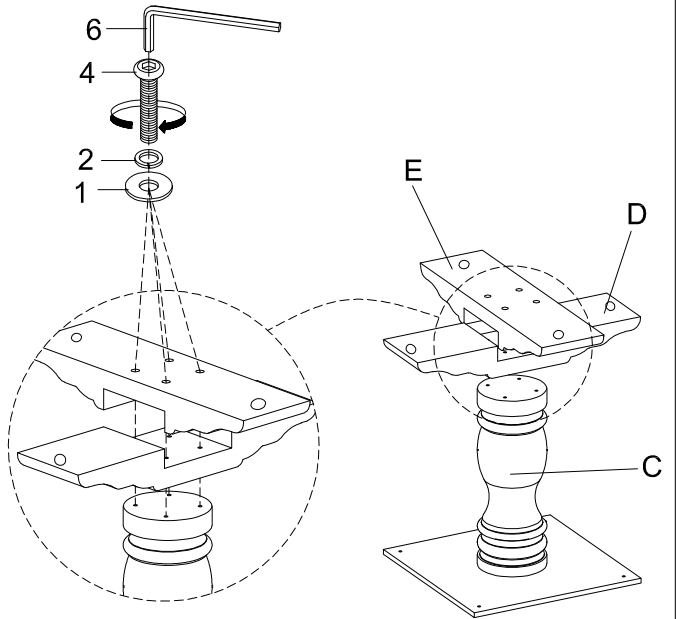

STEP 3

Assemble the leg assembly with the table top (A) by using Allen Wrench (6) with hardware 1,2, and 3.

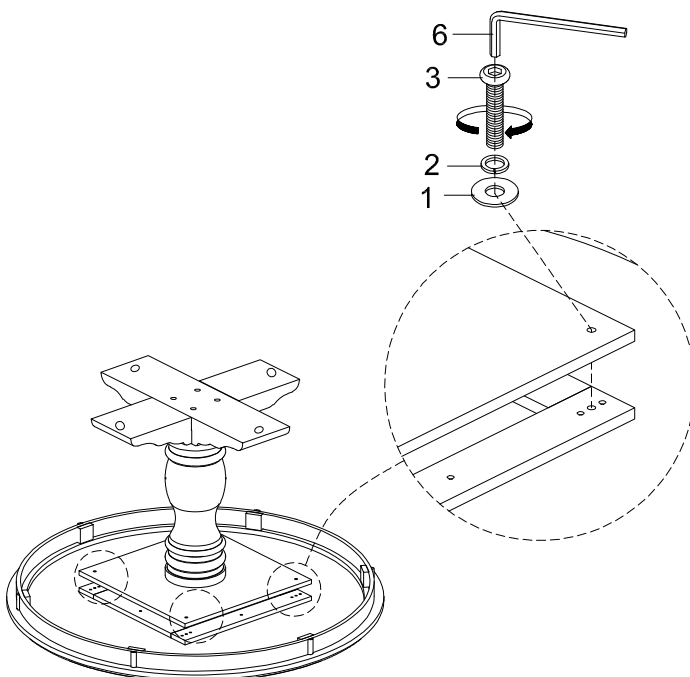

STEP 4

To level the table, place the table on a flat surface and twist the levelers on the bottom of the table legs.

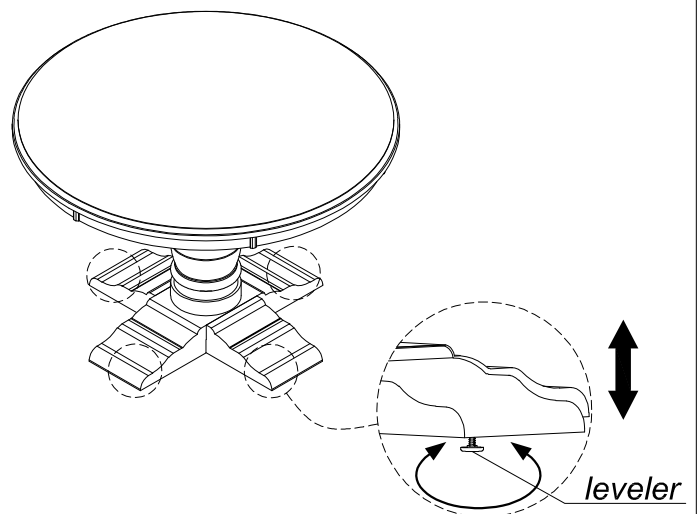

Fully Assembled Table