

Assembly Instructions

ITEM NO. D4125-30

HIGH LINE SERVER - COFFEE
(1 PC/CTN)



Thank you for purchasing this quality product. Be sure to check all packing materials carefully for small parts, which may have come loose inside the carton during shipment. Identify and count all items and compare with the PARTS LIST and/or HARDWARE LIST shown below.







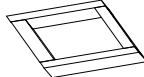



Please read the instructions thoroughly before assembly.

1. We recommend that you assemble this product with the assistance of another person; this will make the assembly easier, and will help eliminate damage to the product or injury to persons during assembly.
2. Please do not tighten screws or bolts until the assembly is completed.
3. To level the chairs or table, before tightening all the screws, the chairs or table must be placed on a flat surface and then tighten the screws.
4. Please put all parts on a non-abrasive floor before assembly and follow the assembly steps to assemble your newly purchased product correctly and efficiently.

PARTS LIST

NO.	COMPONENT	SKETCH	QTY
A	SERVER BODY		1PC
B	SIDE LEG FRAME		2PCS
C	MIDDLE LEG		2PCS
D	CENTER CROSSBAR		1PC

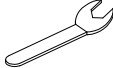
HARDWARE LIST

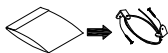
NO.	COMPONENT	SKETCH	QTY
1	FLAT WASHER 5/16" DIA.		10 PCS
2	SPRING WASHER 5/16" DIA.		10 PCS
3	SHORT BOLT 5/16" x 1 1/4"		8 PCS
4	LONG BOLT 5/16" x 2"		2 PCS
5	THREADED BOLT 5/16" x 4"		2 PCS
6	HALF ROUND NUT 5/16"		2 PCS
7	HEXAGON NUT 5/16"		2 PCS
8	WRENCH 5/16"		1 PC
9	ALLEN KEY 5/32"		1 PC
10	ANTI - TIPPING KIT		1 SET

0 1 2 3 4 5 6 7 8 9 10

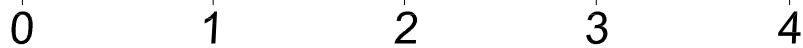

ITEM NO. D4125-30

HIGH LINE SERVER - COFFEE
(1 PC/CTN)

STEP 1

Attach the threaded bolt (5) to the side legs frame (B)

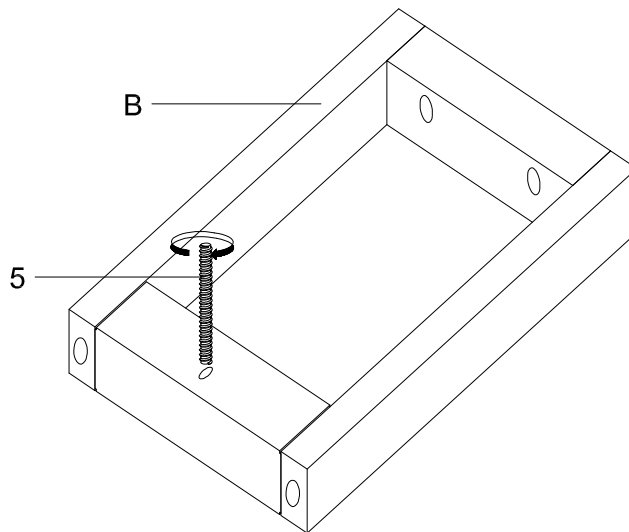

STEP 2

Place the server body (A) back side down on a flat and clean surface.

Assemble the side legs frame (B) to the server body (A) by using Allen wrench (9) with hardware 1, 2, and 3.

*Attention: DO NOT TIGHTEN THE BOLTS.

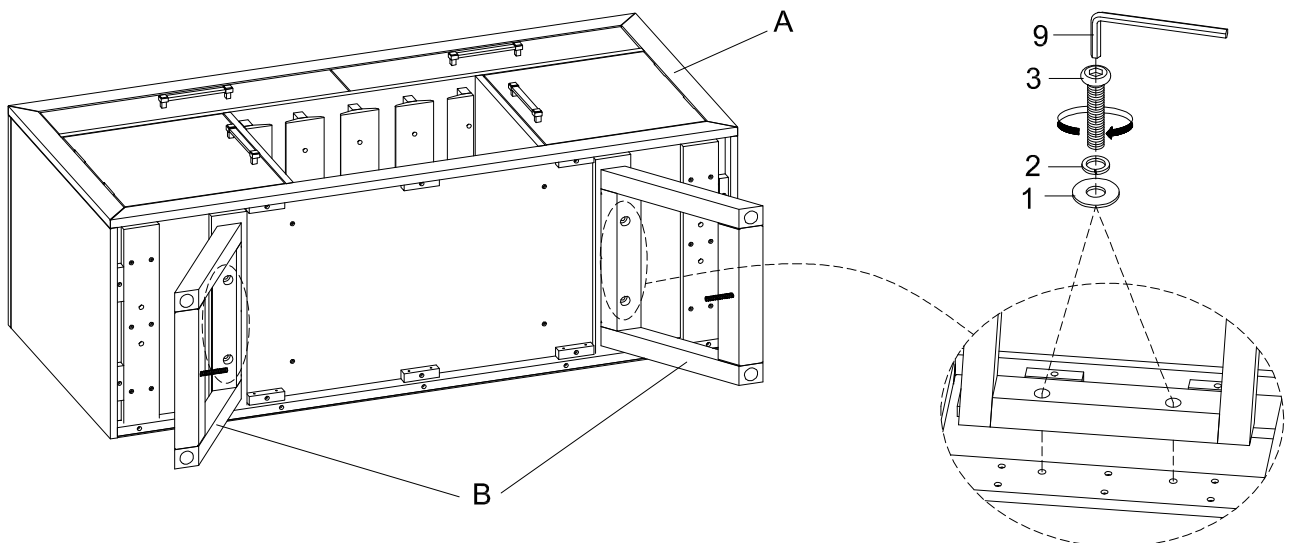

Assembly Instructions

ITEM NO. D4125-30

HIGH LINE SERVER - COFFEE
(1 PC/CTN)

STEP 3

Assemble the center crossbar (D) to the side legs frame (B) by using wrench (8) with hardware 6 and 7.
*Attention: DO NOT TIGHTEN THE BOLTS.

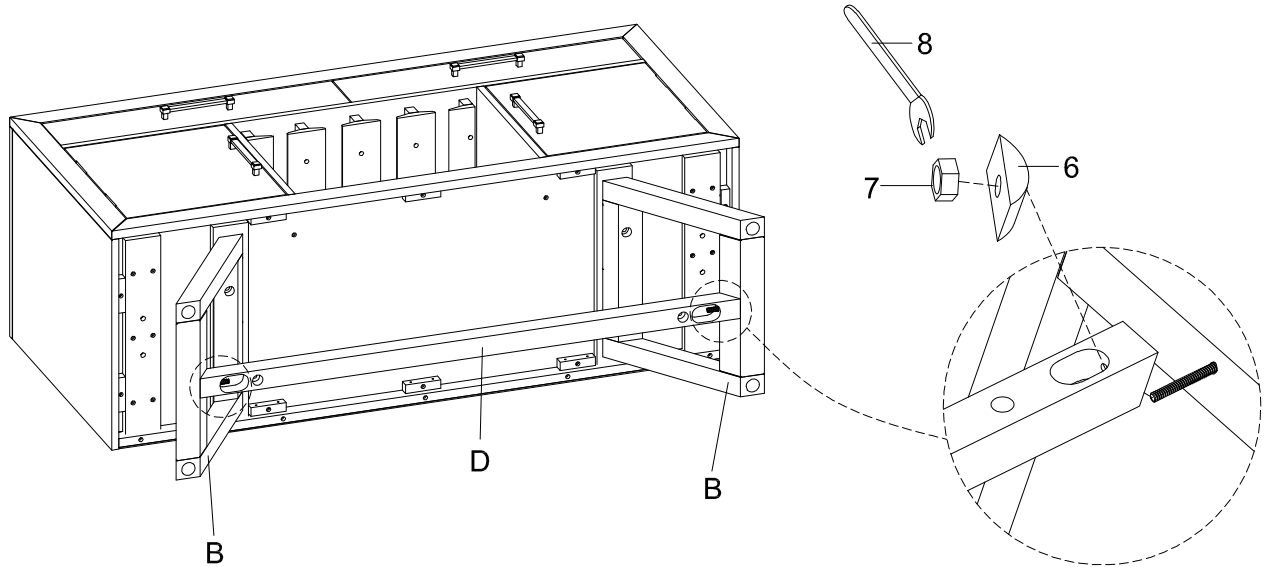

STEP 4

Position the middle leg (C) into the center crossbar (D). Assemble the middle leg (C) to the server body (A) by using Allen key (9) with hardware 1, 2, and 3.
*Attention: DO NOT TIGHTEN THE BOLTS.

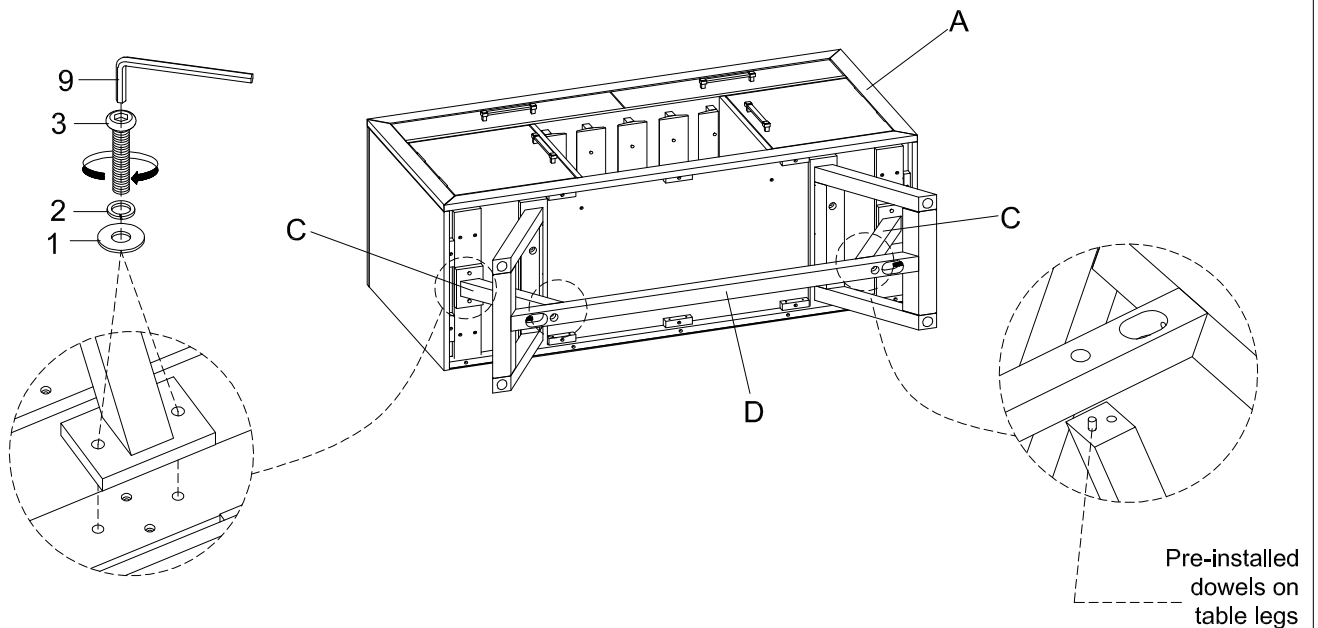

ITEM NO. D4125-30

HIGH LINE SERVER - COFFEE
(1 PC/CTN)

STEP 5

Assemble the center crossbar (D) to the middle leg (C) by using Allen key (9) with hardware 1, 2, and 4. Then tighten all the bolts of server.

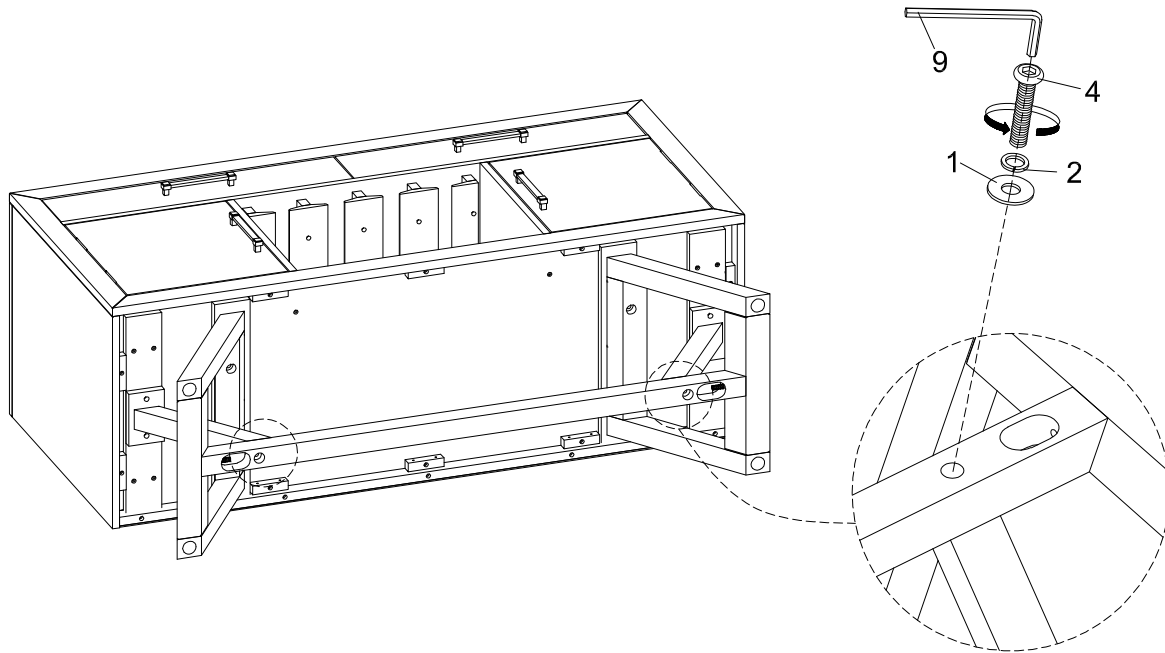

STEP 6

To level the server, place the server on a flat surface and twist the levelers on the bottom of the server side legs frame (B).

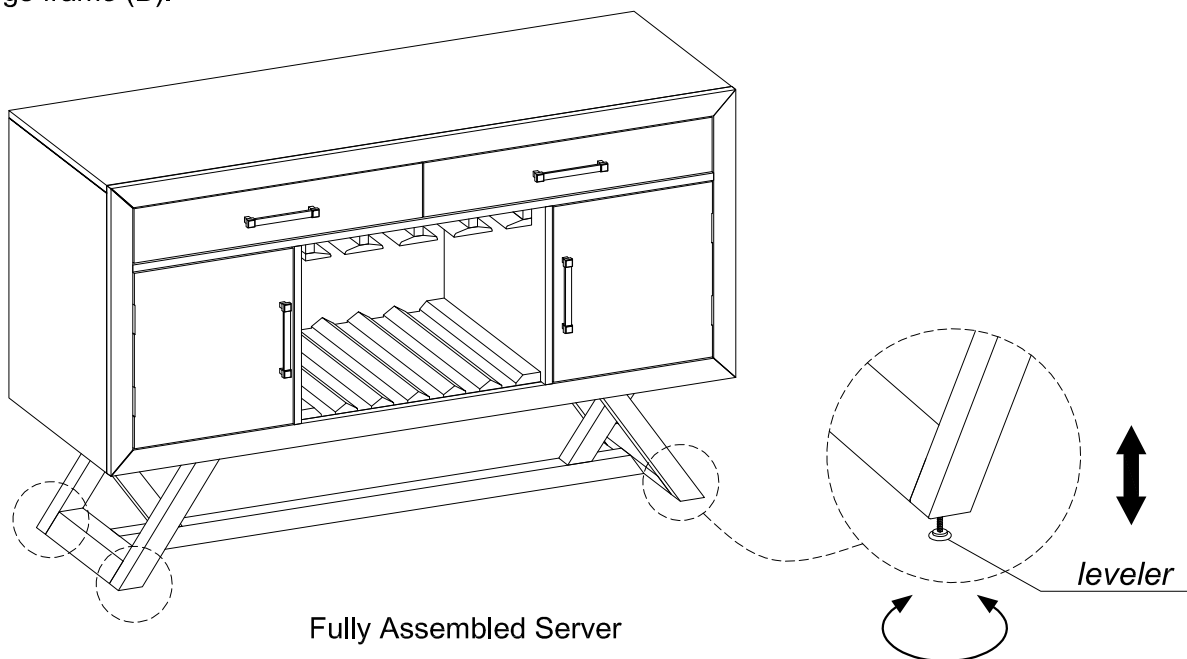

Fully Assembled Server

ITEM NO. D4125-30

HIGH LINE SERVER - COFFEE
(1 PC/CTN)

STEP 7

Install the Anti - tipping kit (10)

