



# Assembly Instruction

## LYRA DINING CHAIR

D3765-20 LYRA DINING CHAIR (2 PER CARTON)

Thank you for purchasing this quality product. Be sure to check all packing materials carefully for small parts, which may have come loose inside the carton during shipment. Identify and count all items and compare with the parts list and/or hardware list shown below.

PARTS LIST			
No.	DESCRIPTION	SKETCH	Q'TY
A	CHAIRBACK		2
B	CUSHION SEAT		2
C	FRONT LEG		4

HARDWARE LIST			
No.	DESCRIPTION	SKETCH	Q'TY
1	Long Bolt (1/4" x 3-1/4")		8
2	Medium Bolt (1/4" x 2-1/4")		8
3	Short Bolt (1/4" x 1-3/4")		6
4	Spring Washer (1/4 ")		22
5	Flat Washer (1/4 ")		22
6	Allen key M4		2

### DO NOT TIGHTEN LEGS UNTIL THE CHAIR IS FULLY ASSEMBLED

**STEP 1:** Assemble the cushion seat (B) with the back legs of the chairback (A) by using Allen Key (6) with hardware 3, 4, and 5.

**\*\*Attention: DO NOT TIGHTEN THE BOLTS.**

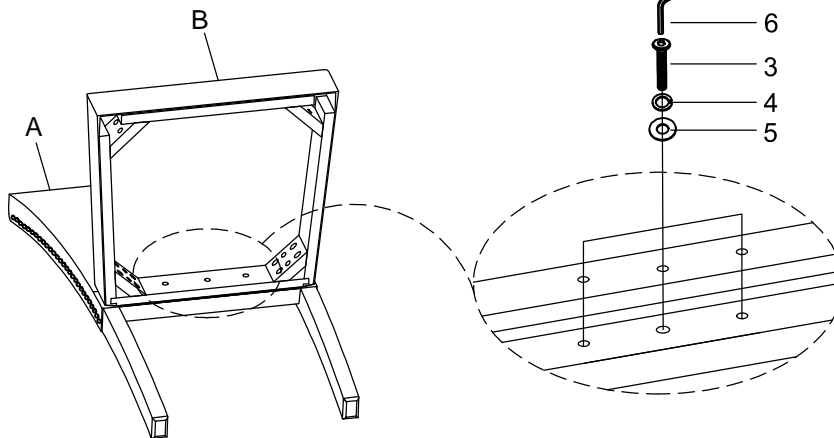

**STEP 2:** Place the chairback (A) on a soft and clean surface. Assemble the cushion seat (B) with the chairback (A) by using Allen Key (6) with hardware 1, 4, and 5.

**\*\*Attention: DO NOT TIGHTEN THE BOLTS.**

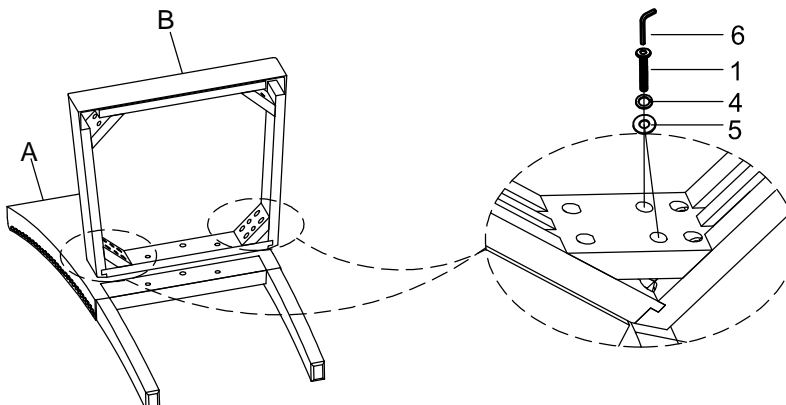

MADE IN VIETNAM

STEP 3: Assemble the front legs (C) with the Cushion Seat (B) by using Allen Key (6) with hardware 2, 4, and 5.

\*\*Attention: DO NOT TIGHTEN THE BOLTS

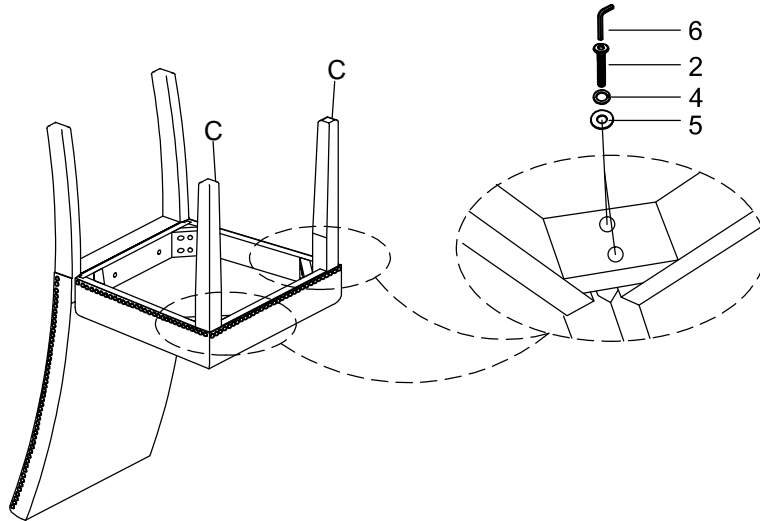

STEP 5: To level the chair, stand the chair up on a flat surface and tighten all the bolts by using Allen Key (6).

