







# ASSEMBLY INSTRUCTIONS

## D1902-30

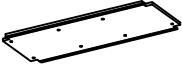



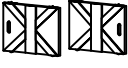
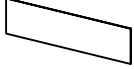

### GULLIVER SERVER

Thank you for purchasing this quality product. Be sure to check all packing materials carefully for small parts, which may have come loose inside the carton during shipment. Identify and count all items and compare with the parts list and/or hardware list shown below.

#### PARTS LIST

NO	DESCRIPTION	SKETCH	QTY
1	TABLE TOP		1 PC
2	TOP PANEL		1 PC
3	LEG		4 PCS
4	SIDE PANEL		2 PCS
5	SIDE PANEL WINE RACK		2 PCS
6	MIDDLE PANEL		1 PC
7	DOOR PANEL (L/R)		2 PCS
8	BACK PANEL		1 PC
9	BOTTOM PANEL		1 PC

#### HARDWARE LIST

NO	DESCRIPTION	SKETCH	QTY
A	JCBB BOLT - M8 x 60mm		8 PCS
B	FLAT WASHER - M8		8 PCS
C	SPRING WASHER - M8		8 PCS
D	ALLEN KEY - M5		1 PC
E	WOOD DOWEL		16 PCS
F	L BRACKET		6 PCS
G	CSK SCREW - M3.5 x 12mm		12 PCS

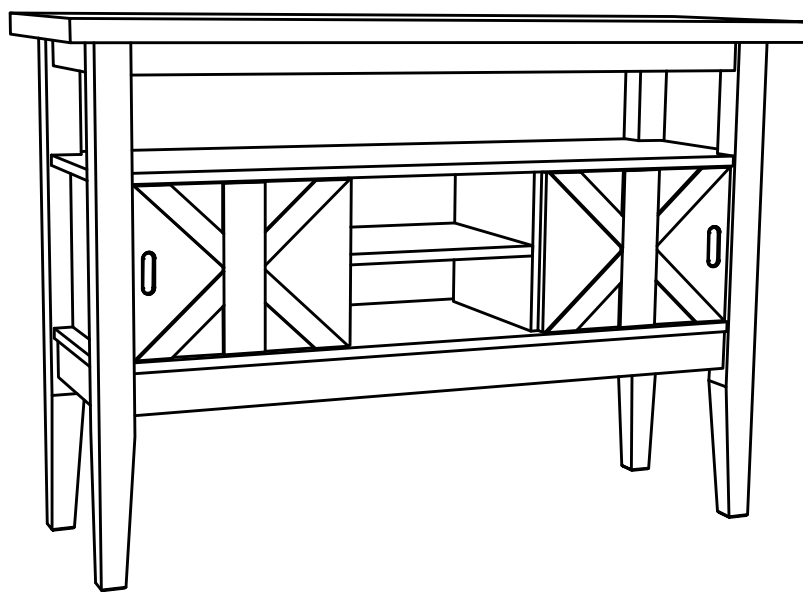

#### IMPORTANT NOTE :

- \* Place all wooden parts on a clean and smooth surface such as a rug or carpet to avoid the parts from being scratched.
- \* Check to be sure that you have all parts and hardware.
- \* Remove all wrapping materials, including staples & packing straps before you start to assemble.
- \* Do not tighten all screws/bolts until all completely assembled.
- \* Keep all hardware parts out of reach of children.
- \* We recommend that you assemble this product with the assistance of another person.

#### Step 1.

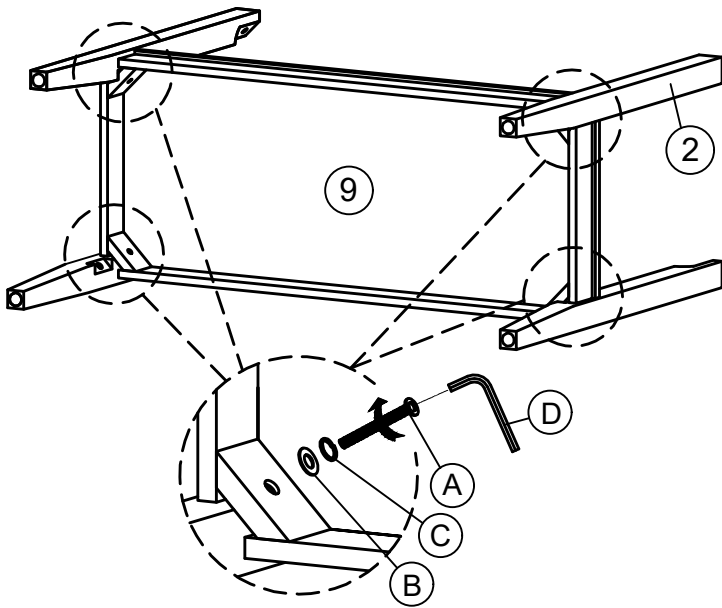

#### Step 2.

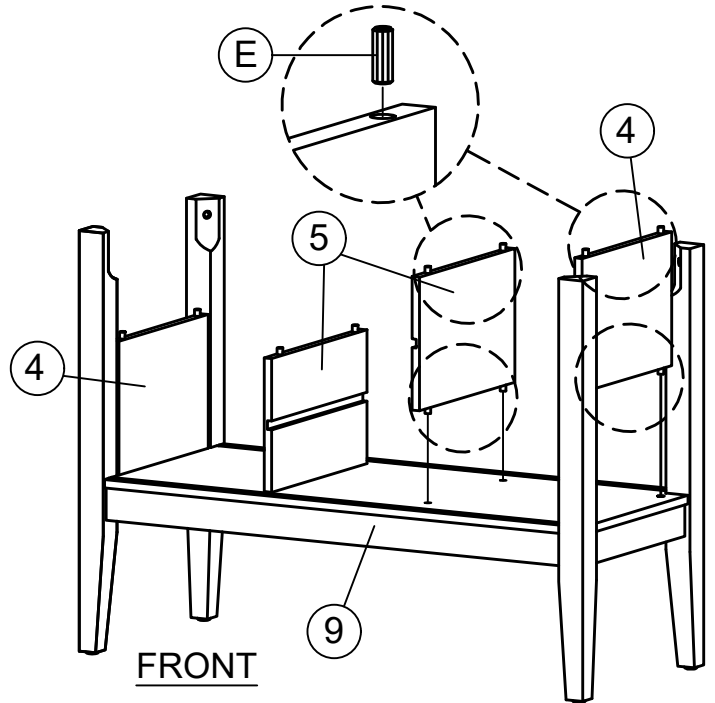

#### Step 3.

PLACE THE BACK PANEL (8) INTO THE FLUTE AND THEN ASSEMBLE THE TOP PANEL (2) TO THE SIDE PANEL (4) AND DIVIDER PANEL (5).

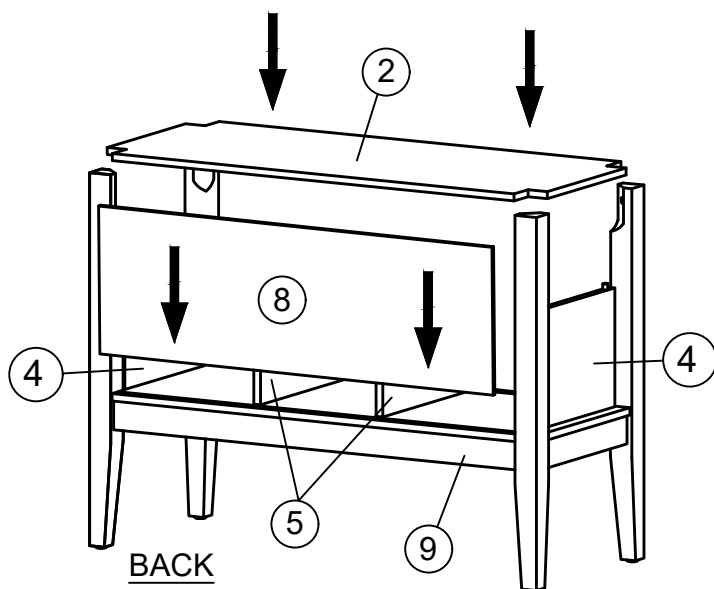

#### Step 4.

SLOT IN THE MIDDLE SHELF (6) INTO THE DIVIDER PANEL (5).

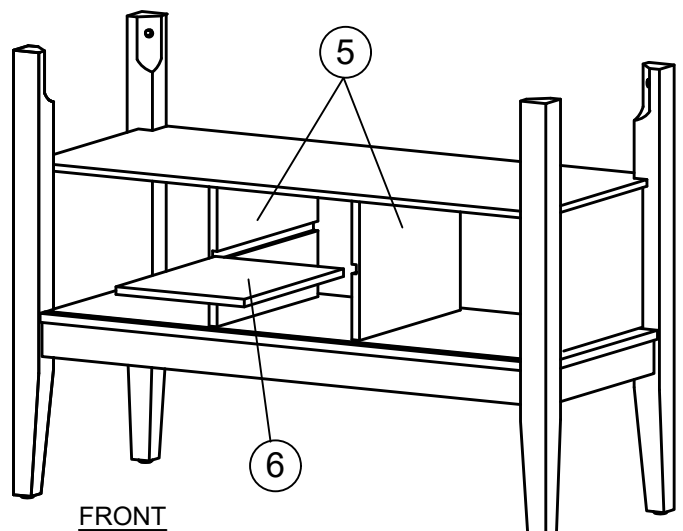

#### Step 5.

SERVER TOP HAVE SHOWN STICKER (B) FOR TOP BACK SIDE. PLEASE ASSEMBLY THE SERVER TOP (STICKER B) AT BACK SIDE.

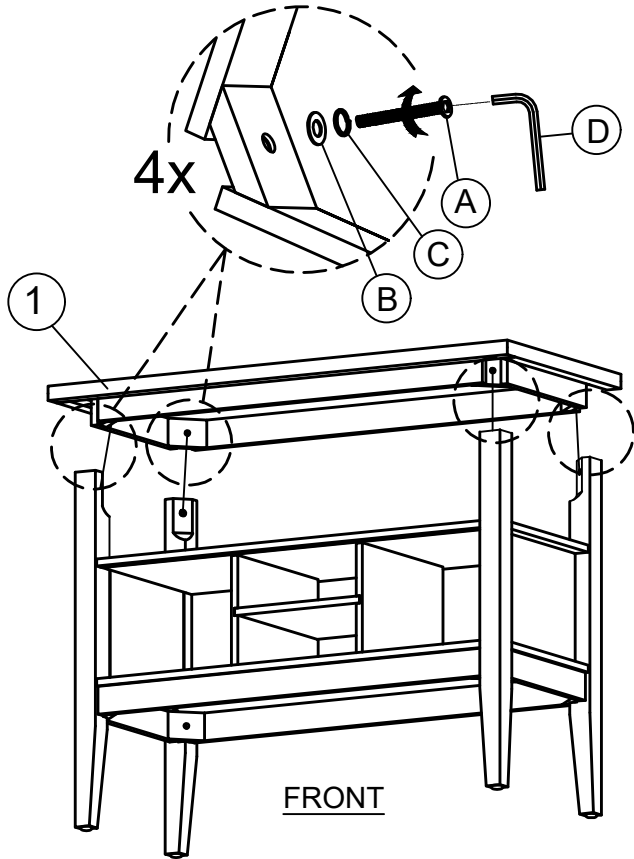

#### Step 6.

**IMPORTANT:**  
TO SECURE THE CENTER SHELF IN PLACE, THE L BRACKETS **MUST** BE INSTALLED AS SHOWN ON STEP 6.

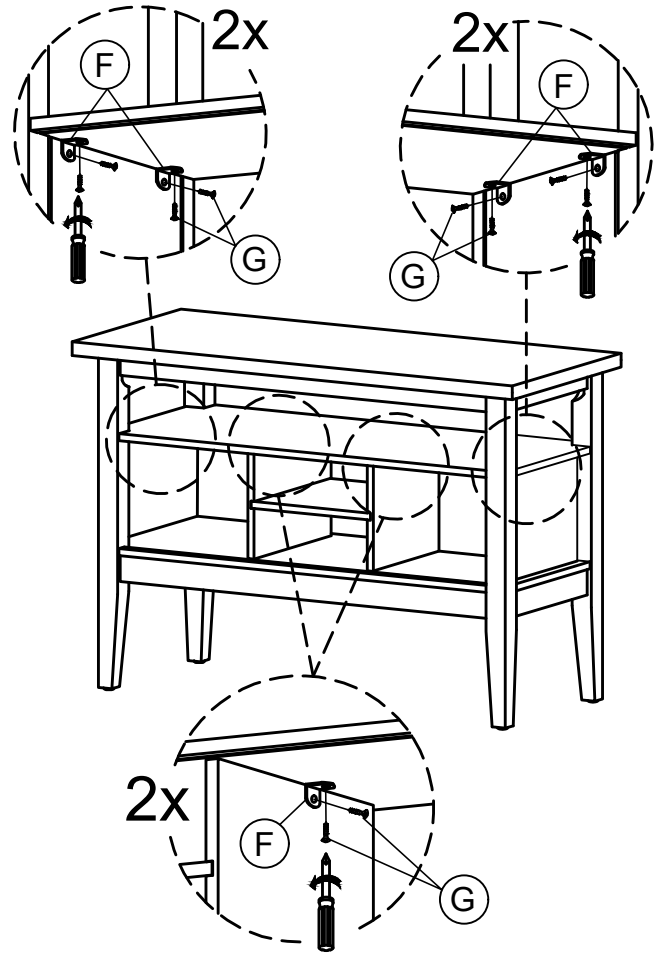

#### Step 7.

UNLOCK THE DOOR BEFORE PLACING THE DOOR PANEL(7) INTO THE FLUTE THEN PUSH BUTTON LOCK TO ENSURE THE DOOR STAY BETWEEN THE FLUTE.

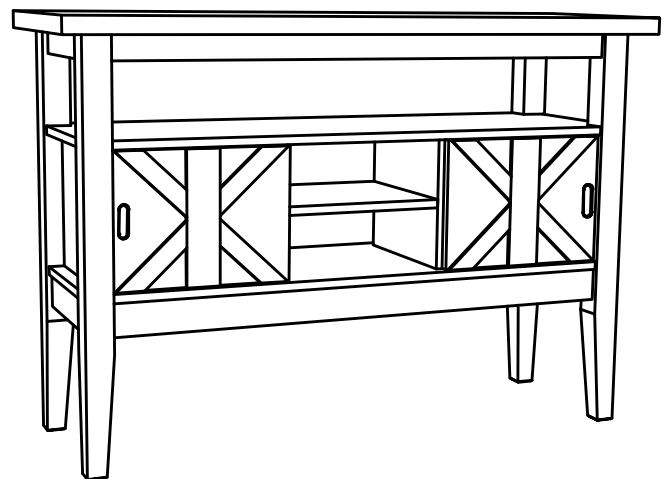
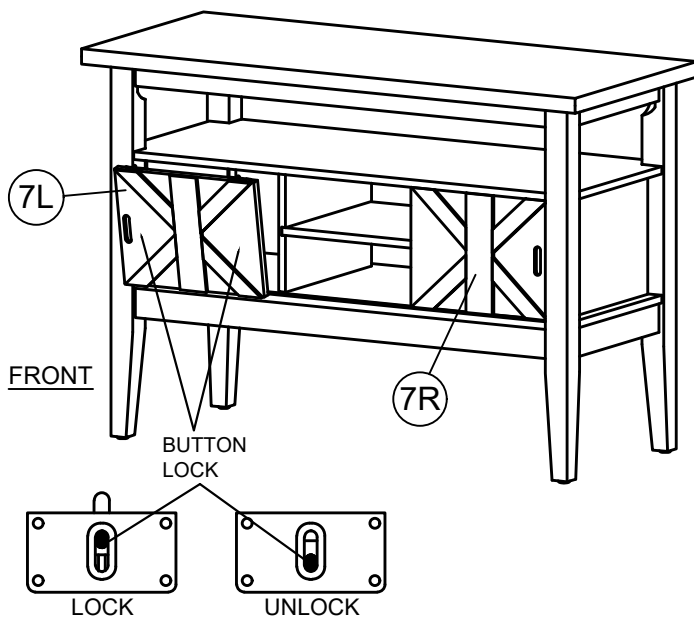

COMPLETE ASSEMBLY