



New  
Classic®  
FURNITURE

# Assembly Instructions

B976-110 RADIANCE 6/6-6/0 K HEADBOARD

B976-120 RADIANCE 6/6-6/0 K FOOTBOARD & SLATS

B976-330 RADIANCE SIDE RAILS

Thank you for purchasing this quality product. Be sure to check all packing materials carefully for small parts, which may have come loose inside the carton during shipment. Identify and count all items and compare with the parts list and hardware list shown below.

PARTS LIST			
NO	DESCRIPTION	SKETCH	QTY
A	HEADBOARD		1 PC
B	FOOTBOARD		1 PC
C	SIDE RAIL		2 PCS
D	SLAT		4 PCS
E	SLAT SUPPORT		8 PCS

HARDWARE LIST			
NO	DESCRIPTION	SKETCH	QTY
1	JCBC BOLT - M6 x 1 1/2"		8 PCS
2	SPRING WASHER - M6		8 PCS
3	CSK SCREW - M4 x 1 1/4"		8 PCS
4	ALLEN KEY - M4		1 PC

PLACE WOOD PARTS ON A CLEAN NON-ABRASIVE SURFACE

**STEP 1 :** Hook the SIDE RAIL (C) to the HEADBOARD (A) closely and push down to fit it.

Repeat STEP 1 with other end of rail to hook onto the FOOTBOARD (B).

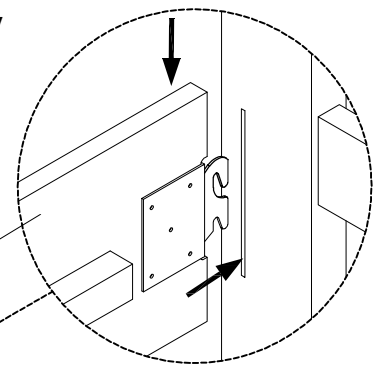

**STEP 3 :** Install the SLAT (D) to the SIDE RAIL (C) by using the screwdriver and CSK SCREW (3).

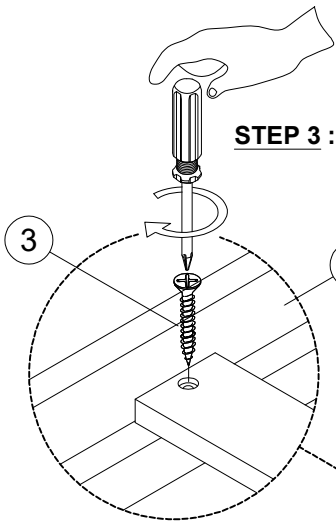

**STEP 2 :** Install the SLAT SUPPORT (E) to the SLAT (D) by using the ALLEN KEY (4) with hardware (1) and (2).

Adjust height of the adjuster for stability and levelling.

