

MOD - 6264

Thank you for purchasing the **MODWAY BED!**

Before you start, here are some helpful advice:

1. We suggest you spend a short time reading through this leaflet and then follow the simple step instructions.
2. Owing to the size and weight of the bed, we recommend that it is assembled by two adults, on a carpeted or padded area, in the room that it is intended for. Approximate assembly time: 35 minutes.
3. Please do not use any tools other than those provided or recommended in these instructions.
4. Please do not throw away any of the packaging or the instruction until you have checked all the components and hardware and the furniture is fully assembled. Please ensure that the packaging is disposed of in a safe environmentally friendly way.
5. Assemble all components loosely until advised to tighten. Depending on use, it may be necessary to tighten the components from time to time, so please save tools that have been provided.
6. Please keep all fitting out of reach of children.

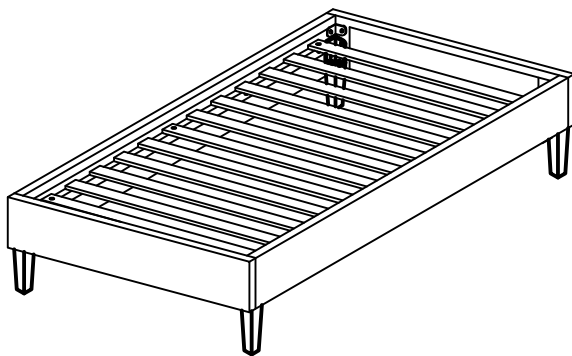

Hardware:

1		JCBB BOLT M8 x 20mm	16 PCS
2		M8 SPRING WASHER	16 PCS
3		M8 FLAT WASHER	16 PCS
4		ALLEN KEY (BALL SHAPE) M5	1 PC
5		5005 L-BRKT	4 PCS
6		WOOD SCREW M4 x 20mm (Black)	8 PCS
7		WOOD SCREW M4 x 32mm	6 PCS

Component:

A.	HEADBOARD	x 1
B.	FOOTBOARD	x 1
C.	SIDE RAIL (L/R)	x 2
D.	BED SLAT	x 1
E.	BED LEG	x 4

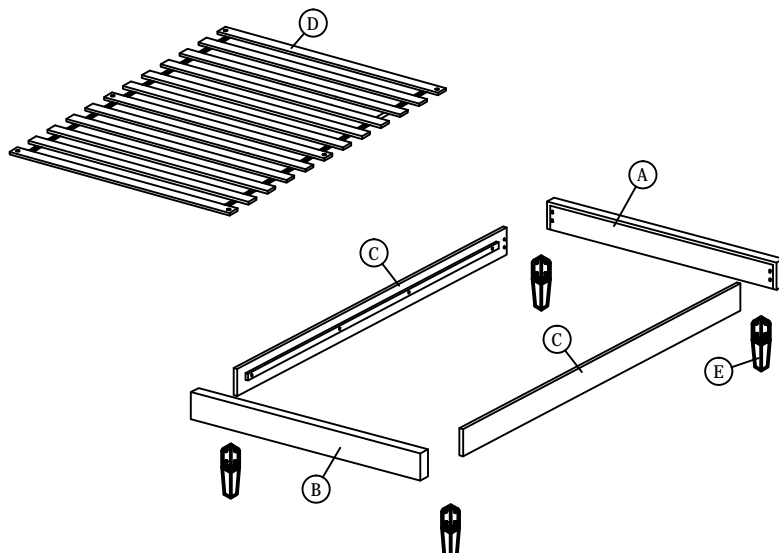

STEP 1

1.1 Secure the Bed Leg (E) & L Bracket (5) to the Headboard (A) and Footboard (B) using hardware parts BOLT (1), SPRING WASHER (2), FLAT WASHER (3), ALLEN KEY (4) & WOOD SCREW (6).

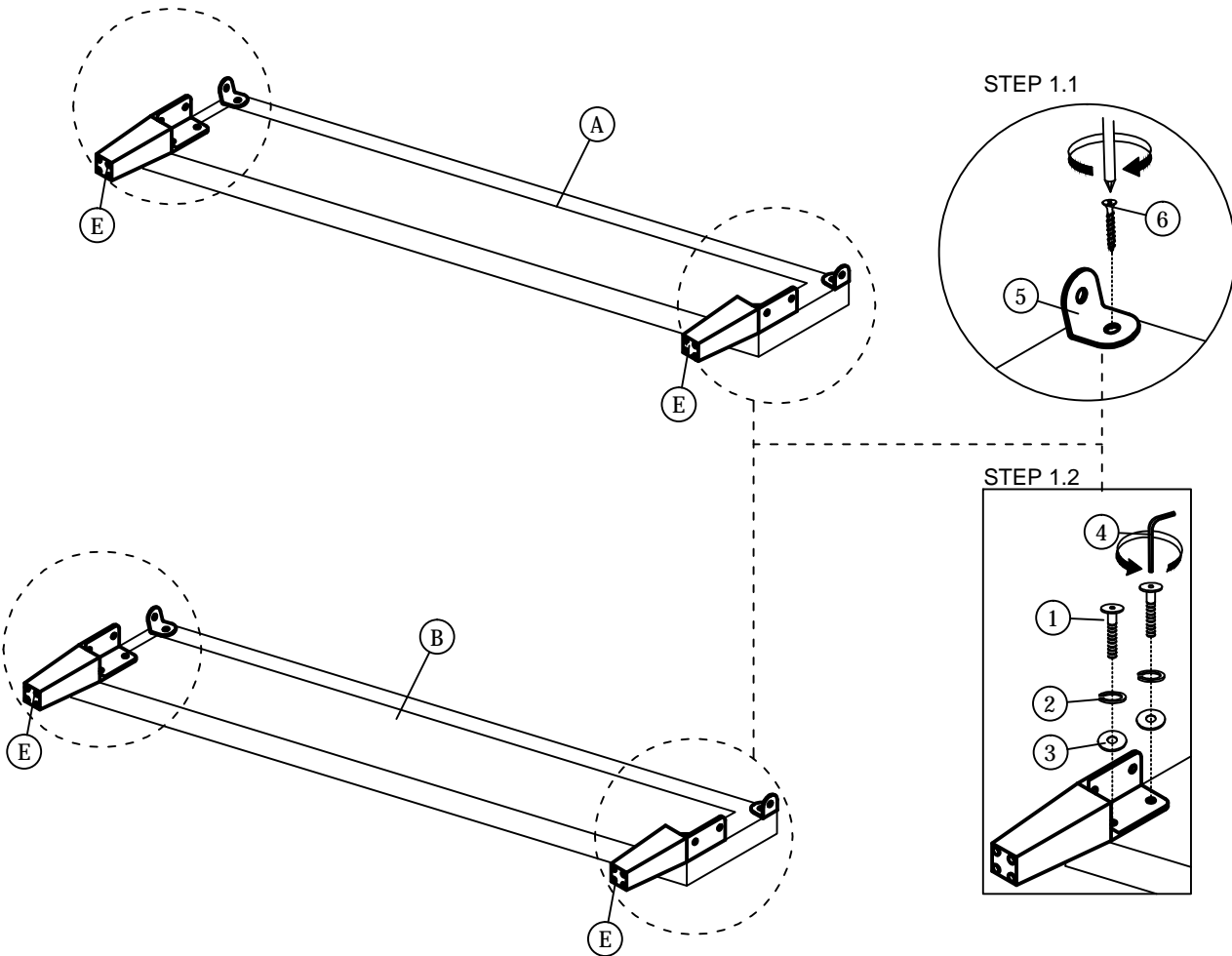

1. JCBB BOLT M8 x 20mm x 8pcs	2. M8 SPRING WASHER x 8pcs	3. M8 FLAT WASHER x 8pcs	4. ALLEN KEY (BALL SHAPE) M5

		Screw Driver
5. 5005 L-BRKT x 4pcs	6. SCREW M4 x 20mm x 4pcs	

STEP 3

3.1 Attach the Side Rails (C) to the Headboard (A) & Footboard (B) using hardware parts BOLT (1), SPRING WASHER (2), FLAT WASHER (3), ALLEN KEY (4) & WOOD SCREW (6).

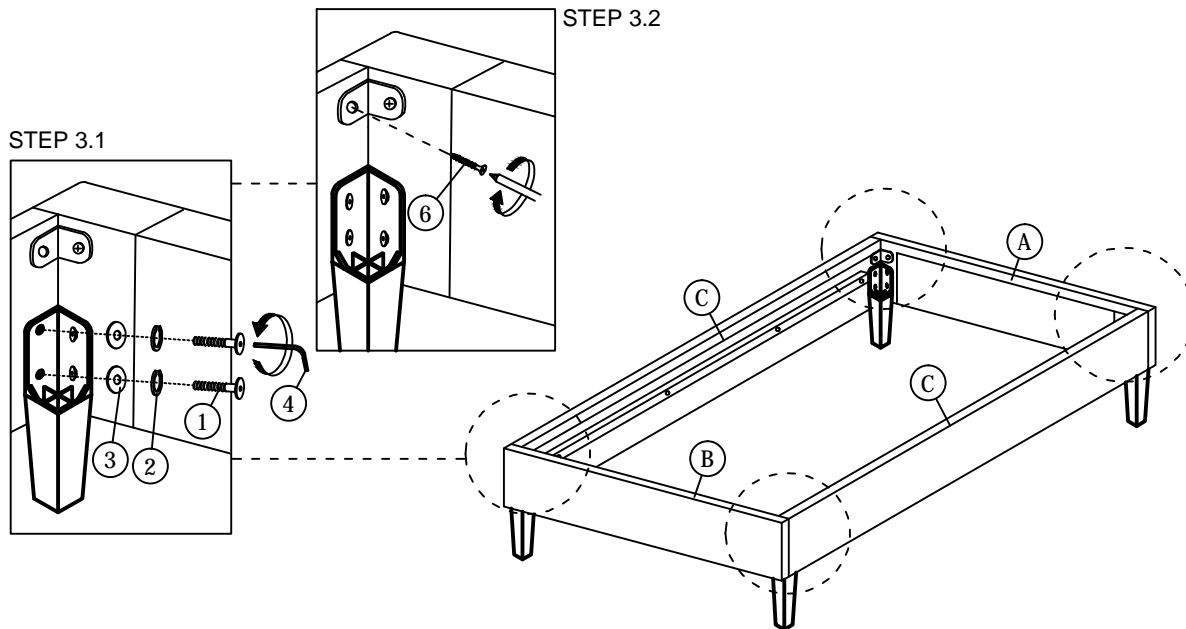

1. JCBB BOLT M8 x 20mm x 8pcs	2. M8 SPRING WASHER x 8pcs	3. M8 FLAT WASHER x 8pcs	4. ALLEN KEY (BALL SHAPE) M5

	Screw Driver
6. SCREW M4 x 20mm x 4pcs	

STEP 4

4.1 Secure the Slats (D) into the Side Rail (C) using hardware parts WOOD SCREW (7).

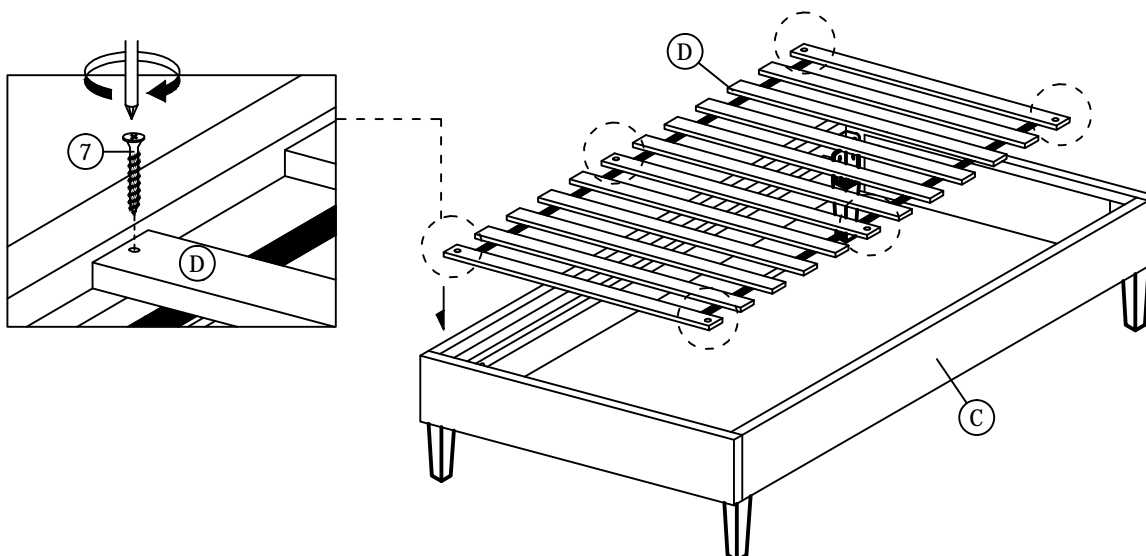

	Screw Driver
7. WOOD SCREW M4 x 32mm x 6pcs	

STEP 5

5.1 Carefully position the assembled bed to the desired location by four adults.

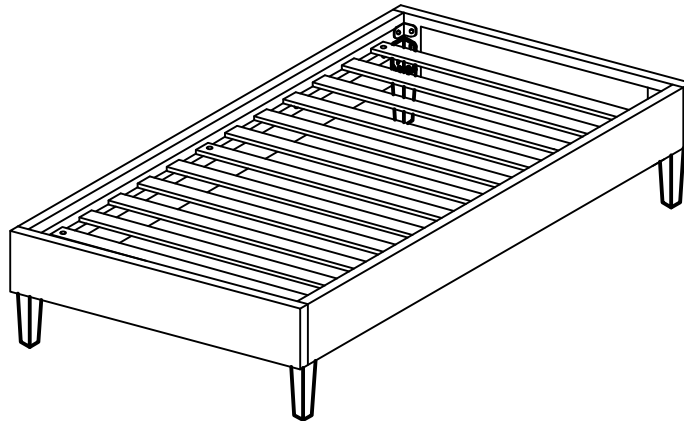

Assembly is complete. The bed is ready to use now!

NOTE: Hardware may loosen over time. Periodically check that all connections are tight.

MOD-6276

Thank you for purchasing the **MODWAY BED!**

Before you start, here are some helpful advice:

1. We suggest you spend a short time reading through this leaflet and then follow the simple step instructions.
2. Owing to the size and weight of the bed, we recommend that it is assembled by two adults, on a carpeted or padded area, in the room that it is intended for. Approximate assembly time: 20 minutes.
3. Please do not use any tools other than those provided or recommended in these instructions.
4. Please do not throw away any of the packaging or the instruction until you have checked all the components and hardware and the furniture is fully assembled. Please ensure that the packaging is disposed of in a safe environmentally friendly way.
5. Assemble all components loosely until advised to tighten. Depending on use, it may be necessary to tighten the components from time to time, so please save tools that have been provided.
6. Please keep all fitting out of reach of children.

Component:

A	HEADBOARD	1 PC
B	SUPPORT WOOD	2 PCS
C	BED FRAME (DOES NOT INCLUDE WITH THE PURCHASE)	-

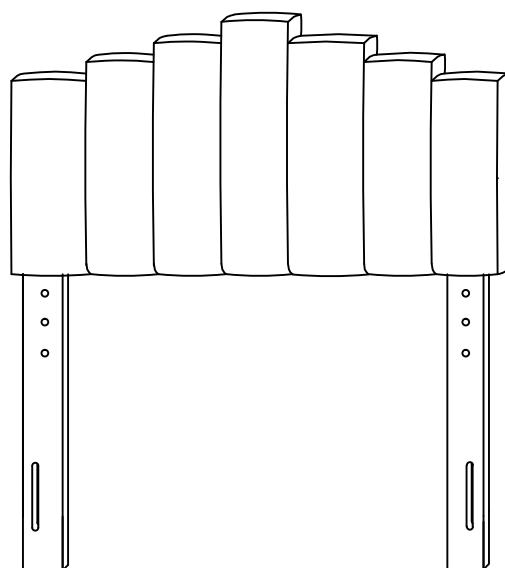

HARDWARE HEADBOARD

- | | | | |
|---|--|---------------------|-------|
| 1 | | JCBB BOLT M8 x 60mm | 4 PCS |
| 2 | | M8 FLAT WASHER | 4 PCS |
| 3 | | M5 ALLEN KEY | 1 PC |

HARDWARE BED FRAME

- | | | | |
|---|--|---------------------|-------|
| 4 | | JCBB BOLT M6 x 60mm | 4 PCS |
| 5 | | JCBB BOLT M6 x 35mm | 4 PCS |
| 6 | | M6 FLAT WASHER | 8 PCS |
| 7 | | M6 SPRING WASHER | 4 PCS |
| 8 | | M6 HEX NUT | 4 PCS |
| 9 | | M4 ALLEN KEY | 1 PC |

STEP 1

1.1 Align pre-drilled support stand holes over the pre-drilled headboard holes according to your desired headboard height

1.2 Secure each support stand by using 2x **JCBB Bolt [1]** and 2x **M8 Flat Washer [2]**. Tighten with supplied **Allen Key [3]**. Repeat the same procedure to secure the other side.

Note: Hardware may loosen over time. Periodically check that all connections are tight.

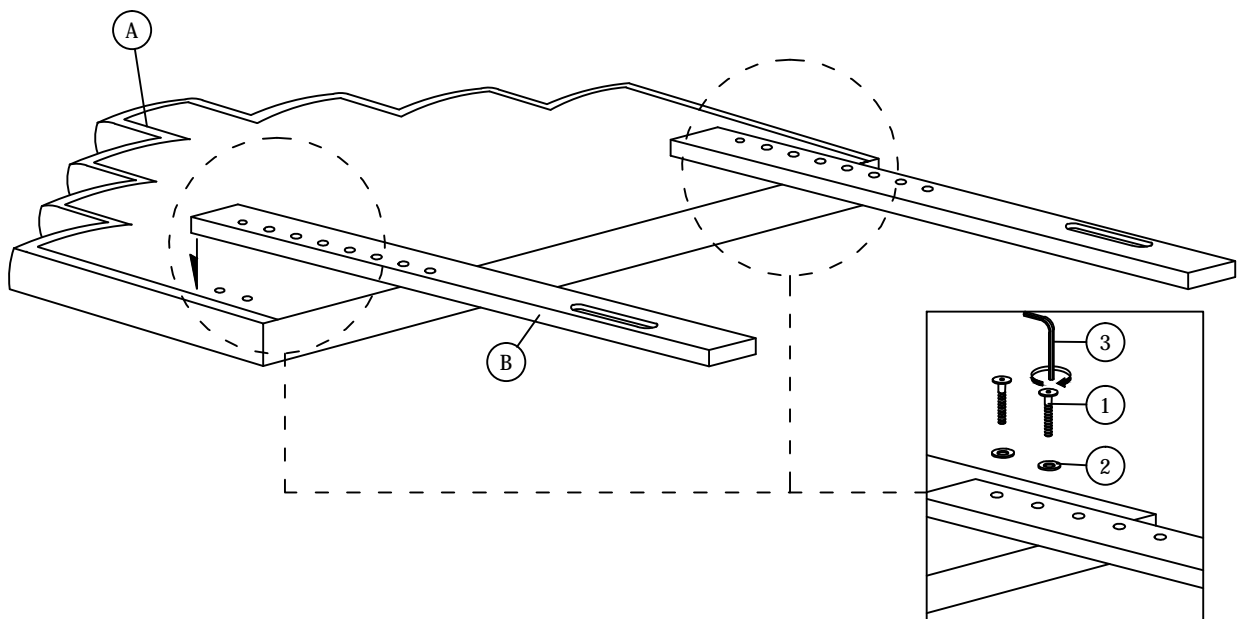

STEP 2

2.1 Line up the bed frame board's pre-drilled holes to match those of the headboard.

2.2 Secure the headboard to the bed frame by using 2x **bolt (4)** for the thicker bed frame, and 2x **bolt (5)** for the thinner bed frame. Before inserting each bolt, place a **spring washer (7)** and **flat washer (6)** on each bolt. Then fit a **flat washer (6)** on the screw as it protrudes through the other side of the bed frame.

2.3 Place a **Hex Nut (8)** after the **flat washer (6)** at the end of each screw. Then tighten by using the **Allen key (9)**.

2.4 Repeat the same procedure for each screw and each side of the bed frame.

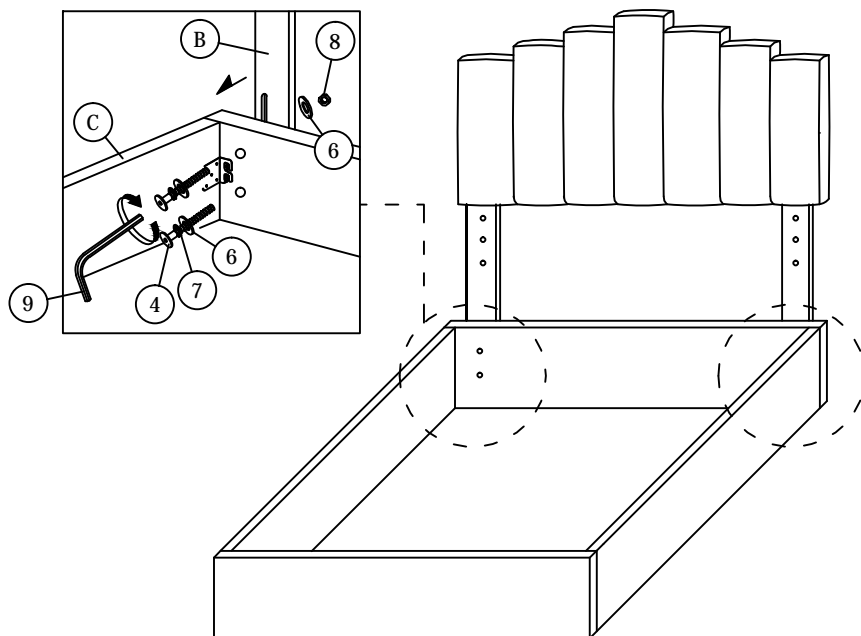

STEP 3

