

Thank you for purchasing the **MODWAY BED !**

Before you start, here are some helpful advice:

1. We suggest you spend a short time reading through this leaflet and then follow the simple step by step instructions.
2. Owing to the size and weight of the bed, we recommend that it is assembled by two adults, on a carpeted or padded area, in the room that it is intended for. Approximate assembly time: 20 minutes.
3. Please do not use any tools other than those provided or recommended in these instructions.
4. Please do not throw away any of the packaging or the instruction until you have checked all the components and hardware and the furniture is fully assembled.
5. Assemble all components loosely until advised to tighten. Depending on use, it may be necessary to tighten the components from time to time, so please save the tools that have been provided.
6. Please keep all small pieces out of reach of children.

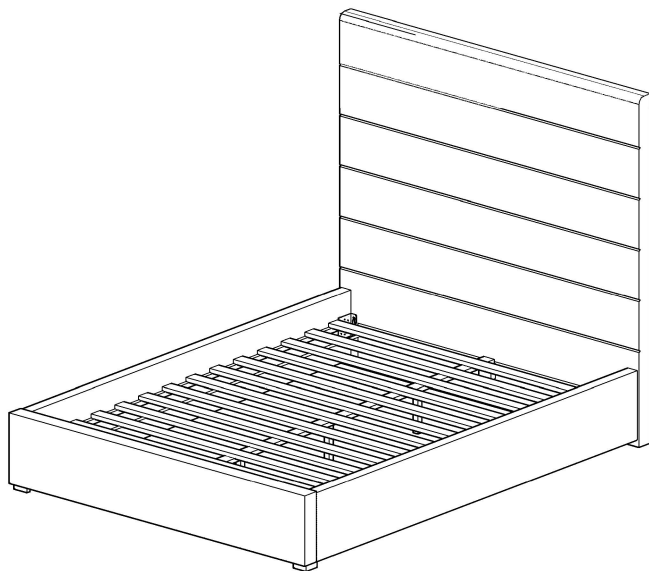

Hardware:

A		JCBC BOLT M6 x 40	9 PCS
B		JCBB BOLT M8 x 35	8 PCS
C		WOOD SCREW M4 X 32mm	6 PCS
D		ADJUSTER	3 PCS
E		ALLEN KEY (BALL SHAPE) M4	1 PC
F		ALLEN KEY M5	1 PC
G		FLAT WASHER	8 PCS
H		JCBC BOLT M6 X 70	4 PCS
I		SPRING WASHER	8 PCS

Compenents :

1 -	HEADBOARD	x 1
2 -	FOOTBOARD	x 1
3 -	SIDERAIL	x 2
4 -	CENTER SUPPORT	x 1
5 -	SUPPORT LEG	x 3
6 -	SUPPORT BAR	x 2
7 -	BED SLAT	x 13
8 -	WOODEN BED LEG	x 2

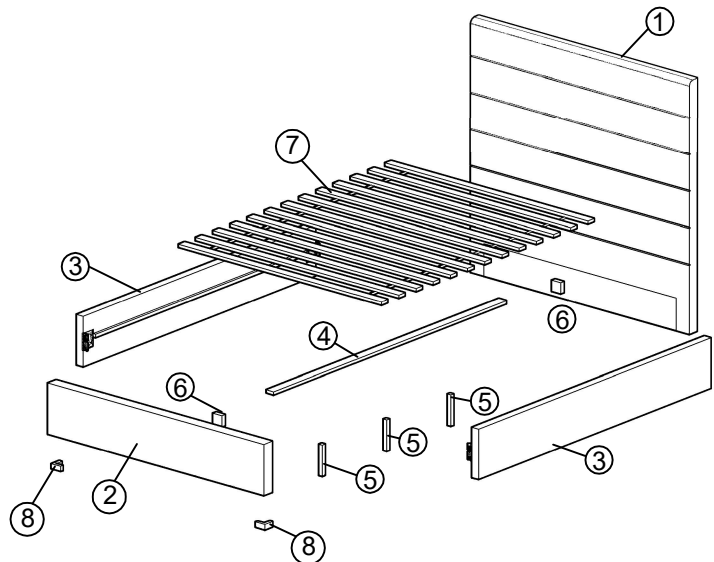

STEP 1:

Place **Footboard (2)** on a carpeted or padded area as shown. Attach **wooden Bed leg (8)** into **Footboard (2)** by inserting **JCBC 70mm Bolt (H)** into the predrill holes at **Footboard(2)**. Tighten with **M4 Allen Key (E)**.

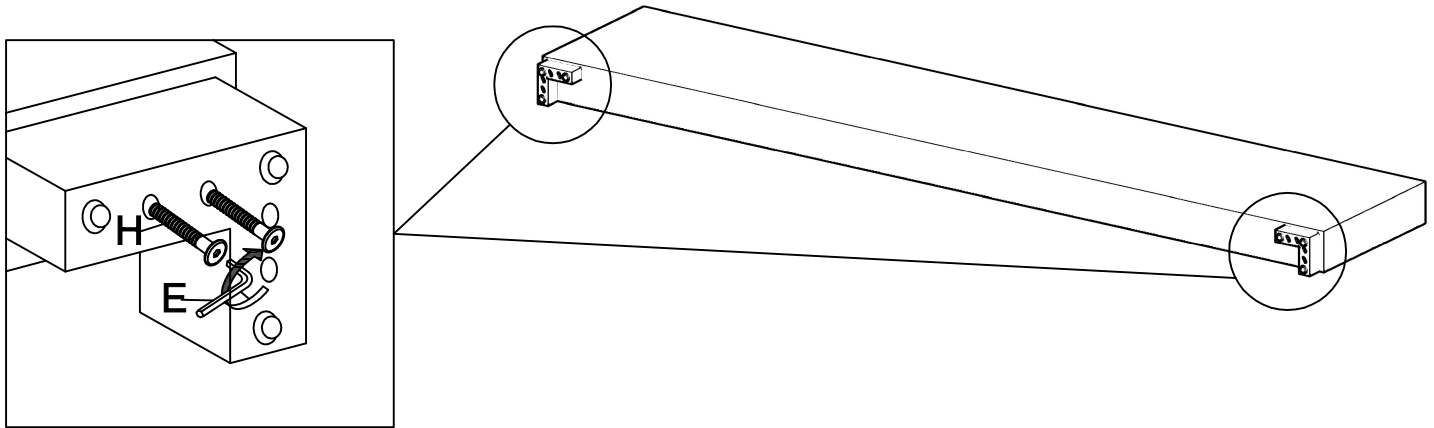

Hx4	Ex1

Hardware & Tool required

STEP 2:

Place **Headboard (1)** , **Footboard (2)** and **Siderail (3)** on a carpeted or padded area as shown. Attach **Side rail (3)** into **Headboard (1)** and **Footboard (2)** by inserting **Flat Washer (G)** and **JCBB 35mm Bolt (B)** into the holes of **Headboard (1)** and **Footboard(2)**. Tighten with **M5 Allen Key (F)**. Repeat the same steps for other three corner

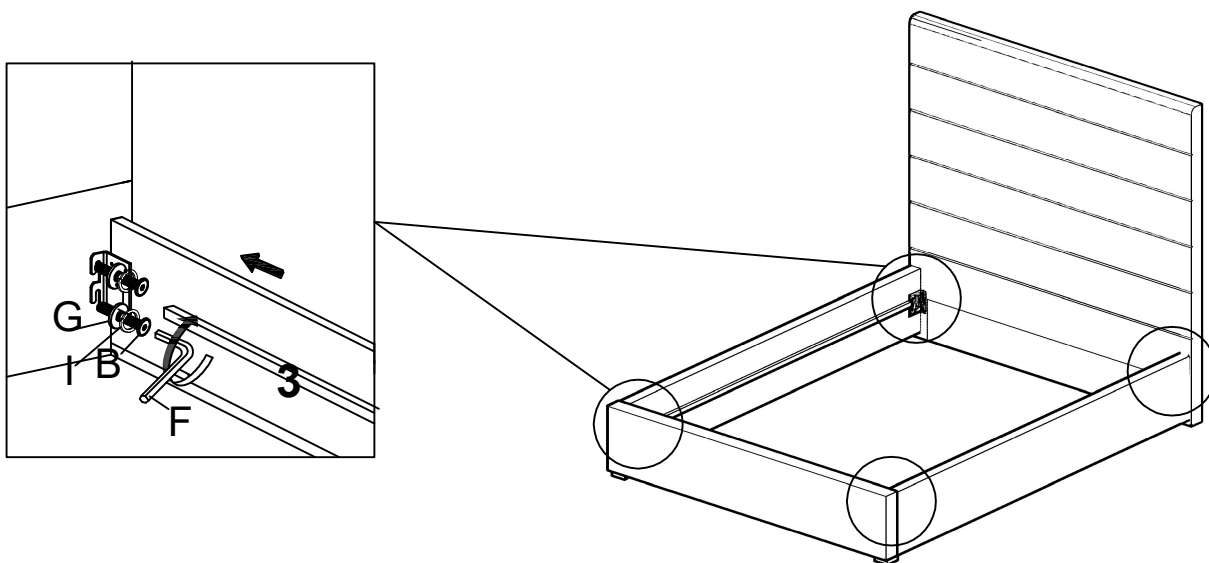

Bx8	Gx8	Fx1	Ix8

Hardware & Tool required

STEP 3:

1. Attach the **Support Bar (6)** to the predrilled hole at center of **Headboard (1)**. Place the **JCBC bolt 40MM(A)** and tighten by using **M4 Allen Key(E)**. Repeat again at **Footboard(2)**.
2. Place the **Center Support bar (4)** as per picture shown and attach **JCBC bolt 40MM(A)** and tighten using **M4 Allen Key(E)**. Repeat again at **Footboard(2)**
3. Attach the **Adjuster(D)** to the two **Center Support Leg(5)**.
4. Attach the **Center Support Leg(5)** to the **Center support bar(4)** as shown in diagram., Insert **JCBC 40MM (A)** to the predrilled hole and tighten by using **M4 Allen Key(E)**

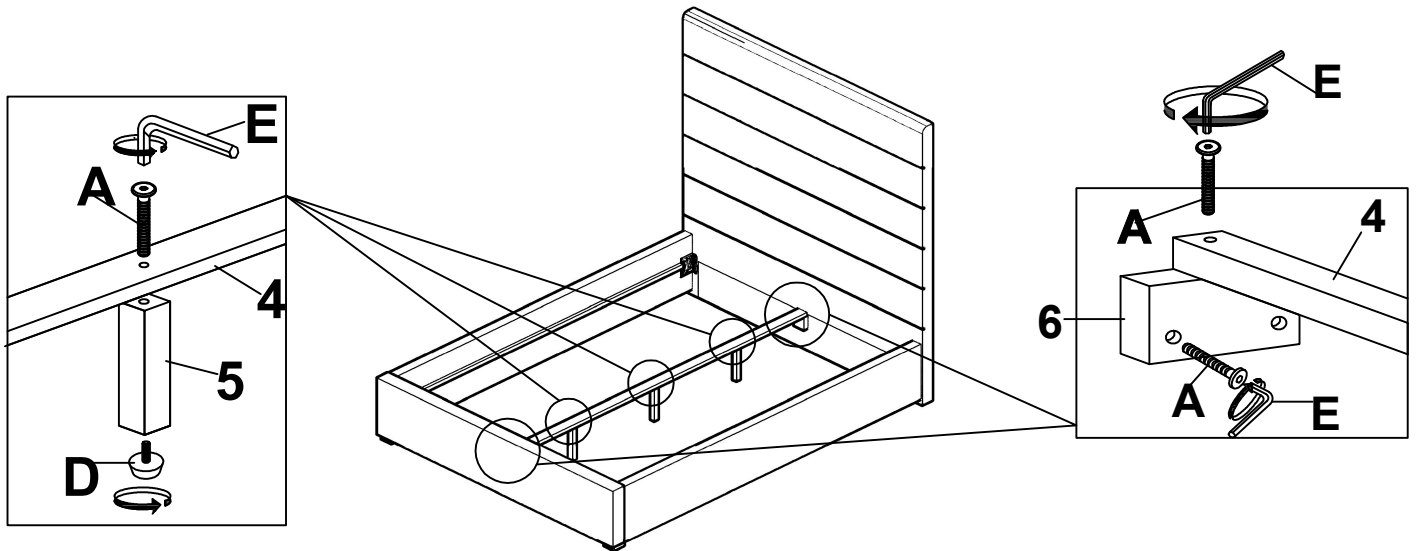

Ax10	Dx3	Ex1

Hardware & Tool required

STEP 4:

Attach **Slat (7)** into **bed** by inserting **CSK screw (C)** into the predrilled holes on the **Slat (7)** . Tighten with **Screwdriver (Not provided)** .

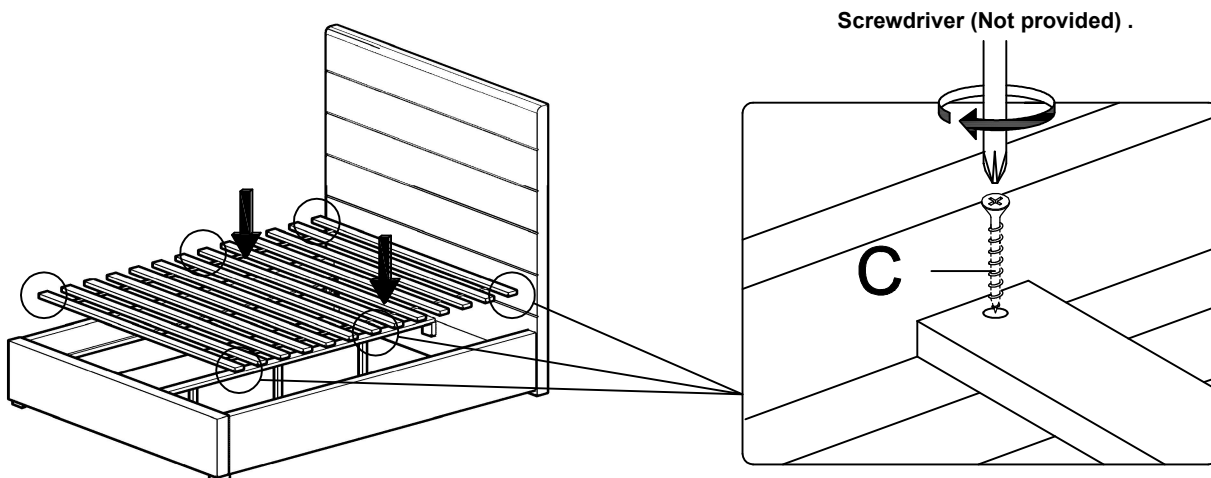

Assembly is completed. The bed is ready to enjoy now!

Cx6

Hardware & Tool required