

MOD-5534 TWIN HEADBOARD





Thank you for purchasing the MODWAY TWIN HEADBOARD!

Before you start, here is some helpful advice:

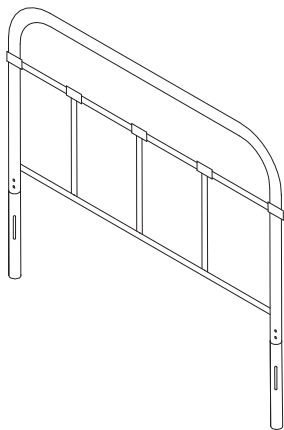
1. We suggest you spend a short time reading through this leaflet and then follow the simple step-by-step instructions.
2. Owing to the size and weight of the headboard, we recommend that it is assembled by two adults, on a carpeted or padded area, in the room that it is intended for. Approximately assembly time: 30 minutes.
3. Please do not use any tools other than those provided or recommended in these instructions.
4. Please do not throw away any of the packaging or the instruction until you have checked all the components and hardware and the furniture is fully assembled. Please ensure that the packaging is disposed of in a safe and environmentally friendly way.
5. Assemble all components loosely until advised to tighten. Depending on use, it may be necessary to tighten the components from time to time, so please save the tools that has been provided.
6. Please keep all fitting out of reach of children.



Hardware:

| | | | |
|---|--|-----------------|----|
| A |  | Bolt M6x20mm | x4 |
| B |  | Arc Washer M6 | x4 |
| C |  | Allen Wrench M5 | x1 |

Component:

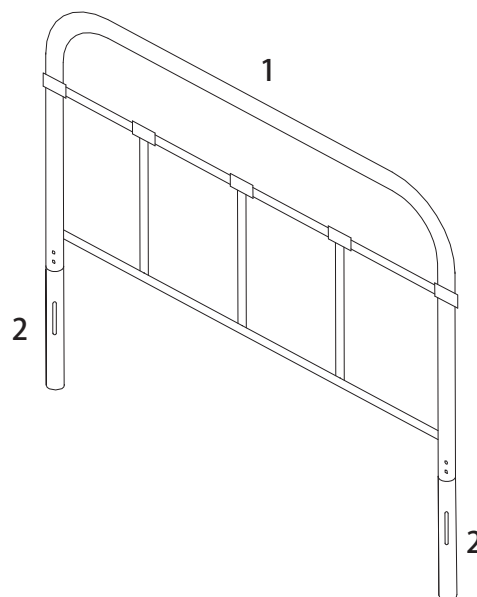

1 Headboard x1

2 Low Post x2

MOD-5534 TWIN HEADBOARD



STEP 1:

Insert Low Post (2) into Headboard (1) as shown.

Attach by using Arc Washer (B) and Bolt (A) from the holes on the back of Low Post (2) and Headboard (1).

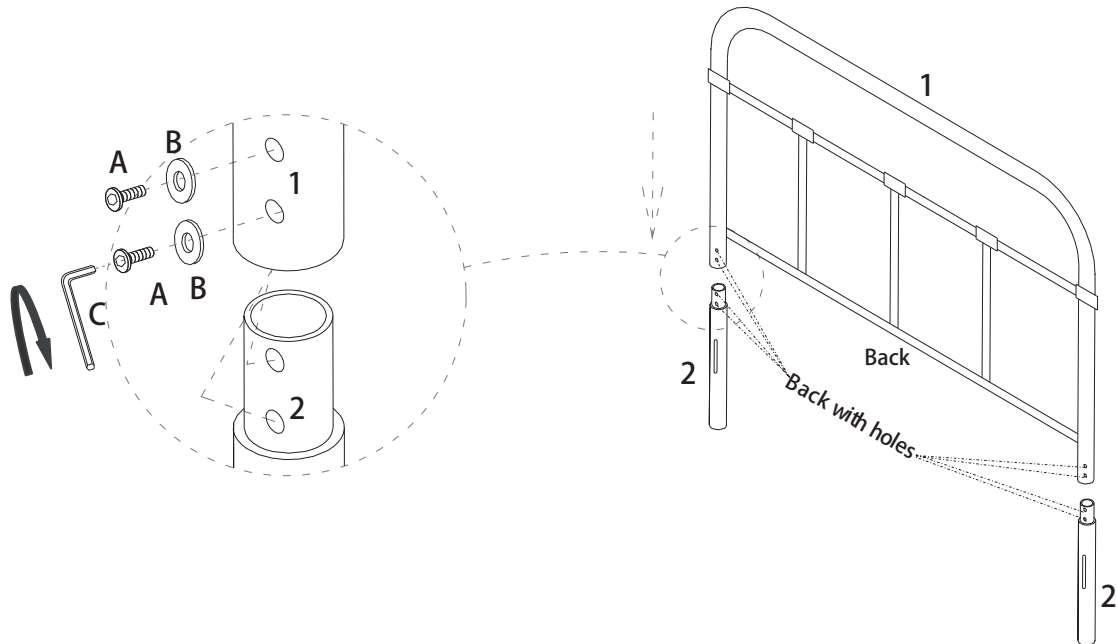
Use Allen Wrench (C) to tighten Bolts (A) clockwise until secure at this step.



| | | |
|---|---|---|
|  |  |  |
| Ax4 | Bx4 | Cx1 |

Hardware & Tool required

STEP 2:

Carefully turn up the assembled Headboard (1) by two adults.

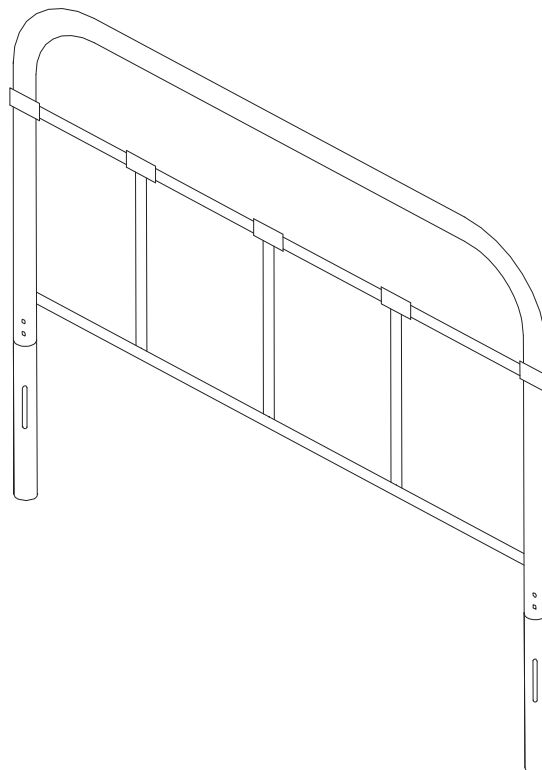

Assembly is completed. The headboard is ready to use now!





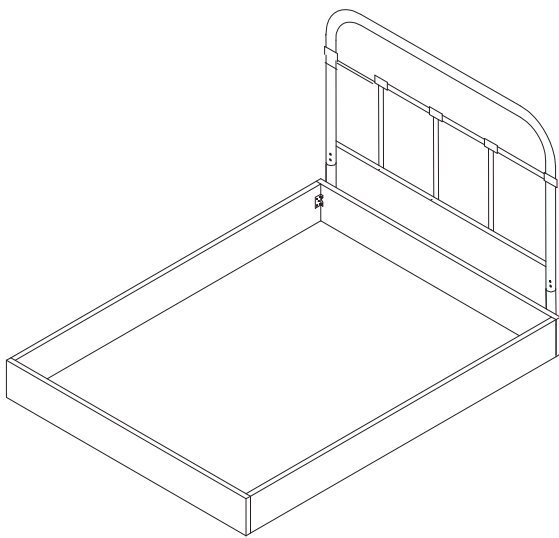

NOTE: Hardware may loosen over time. Periodically check that all connections are tight.

ASSEMBLY INSTRUCTIONS
OPTION 1

OPTION 1



Hardware:

| | | | |
|---|--|------------------|----|
| A |  | Bolt M6x45mm | x4 |
| B |  | Bolt M6x65mm | x4 |
| C |  | Arc Washer M6 | x8 |
| D |  | Spring Washer M6 | x4 |
| E |  | Hex Nut M6 | x4 |
| F |  | Allen Wrench M4 | x1 |

Component:

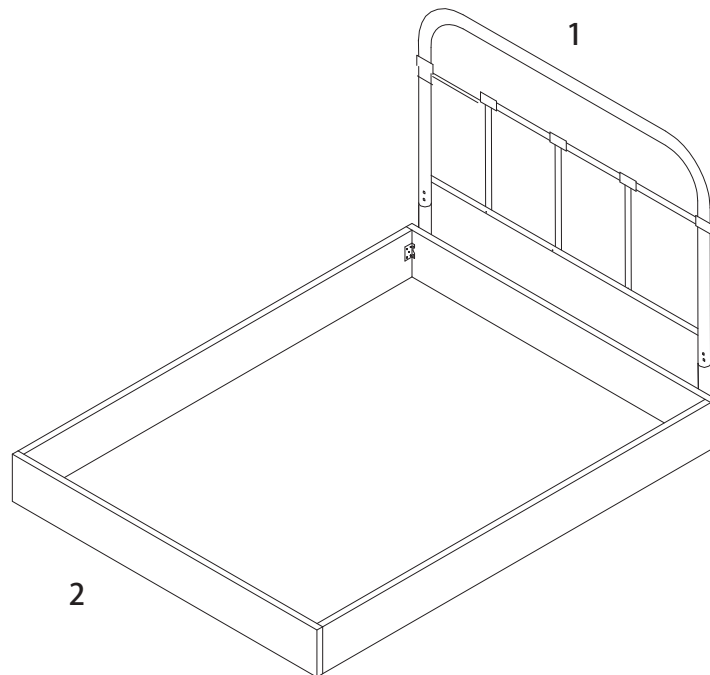

OPTION 1

1 Headboard x1

2 Bed Frame x1

Note: Extra hardware were provided for attaching the headboard to your Bed Frame (use is optional).

STEP 1:

Line up the **Bed Frame (2)** board's pre-drilled holes to match those of the **Headboard (1)**.

Secure the **Headboard (1)** to the **Bed Frame (2)** by using 2 pieces of **Bolt (B)** for the thicker **Bed Frame (2)**, and 2 pieces of **Bolt (A)** for the thinner **Bed Frame (2)**.

Before inserting each bolt, place 1 piece of **Spring Washer (D)** and **Arc Washer (C)** on each bolt. Then fit 1 piece of **Arc Washer (C)** on the bolt as it protrudes through the other side of the **Bed Frame (2)**.

Place 1 piece of **Hex Nut (E)** after the **Arc Washer (C)** at the end of each bolt. Then tighten the **Bolts (A or B)** by using the **Allen Wrench (F)**.

Repeat the same procedure for each bolt and each side of the **Bed Frame (2)**.

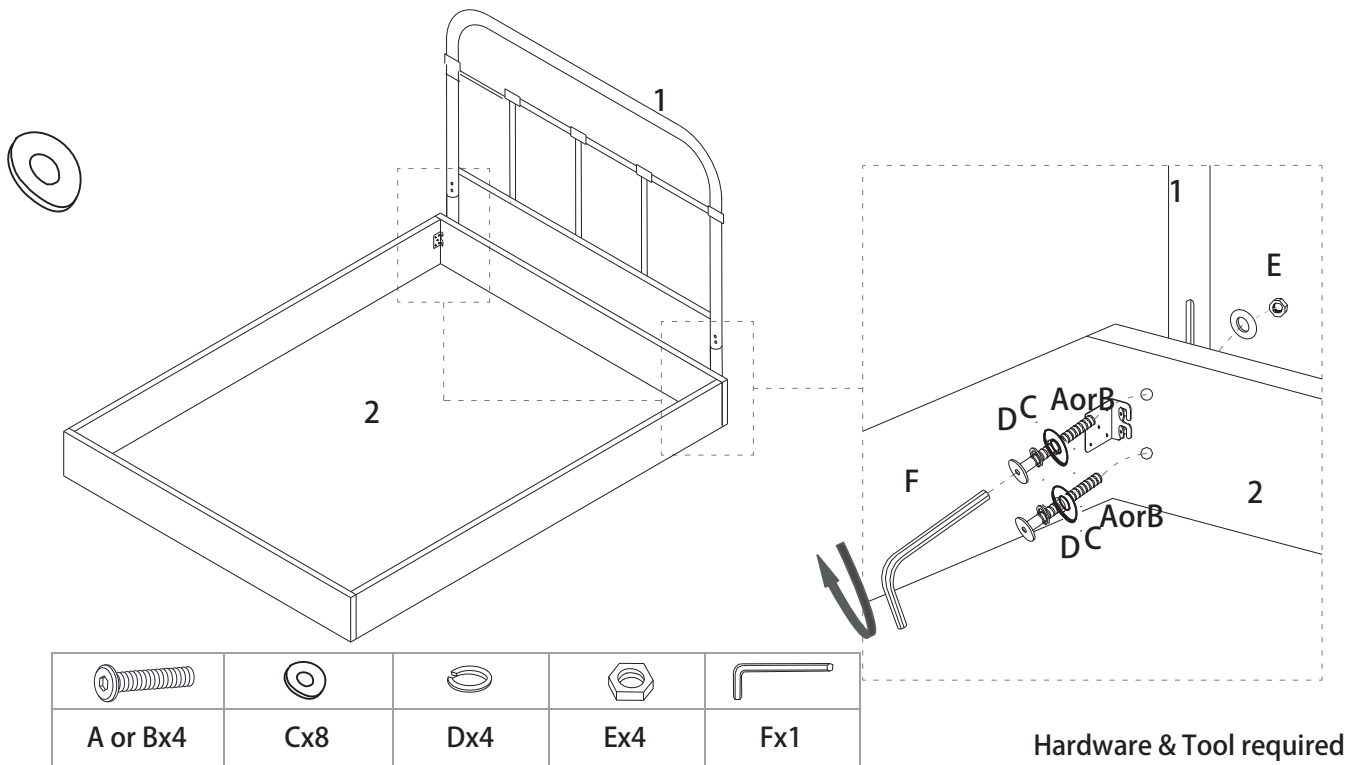

STEP 2:

Carefully position the assembled bed to the desired location by four adults.

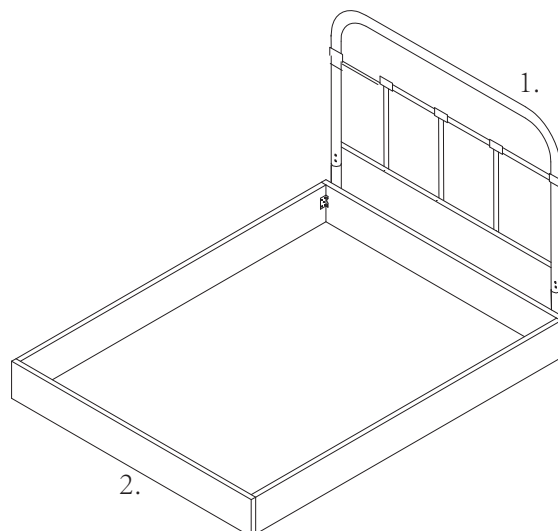

Assembly is completed. The bed is ready to use now!

NOTE: Hardware may loosen over time. Periodically check that all connections are tight.



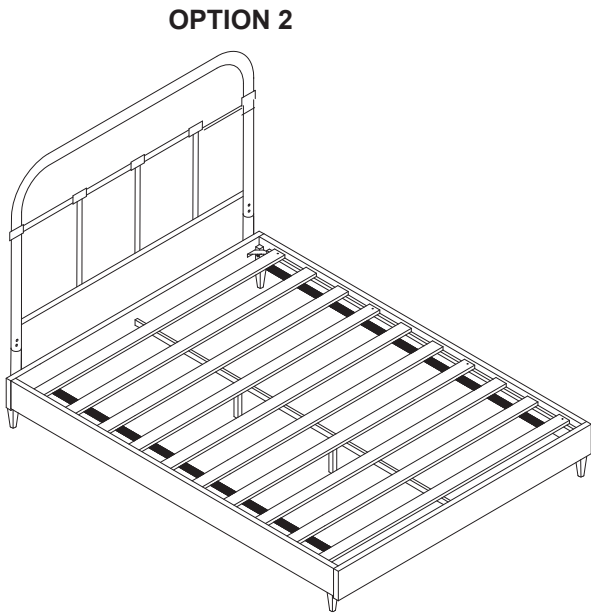

ASSEMBLY INSTRUCTIONS

OPTION 2

Note: This is assembly instruction for Headboard connect to MODWAY Bed Frame MOD-5347/5348/5349/5350/5351/5352/5353/5354/5357/5358/5359/5360/5361/5362/5363/5364.



Hardware:

| | | | |
|---|--|------------------|----|
| A |  | Bolt M6x45mm | x4 |
| B |  | Bolt M6x65mm | x4 |
| C |  | Arc Washer M6 | x4 |
| D |  | Spring Washer M6 | x4 |
| F |  | Allen Wrench M4 | x1 |

Component:

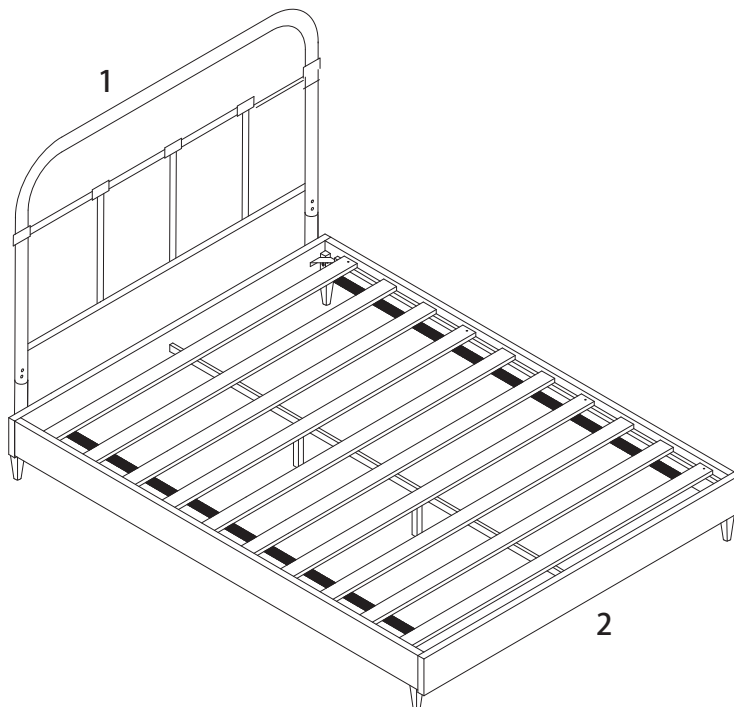

OPTION 2

1 Headboard x1

2 Bed Frame x1

STEP 1:





Line up the **Bed Frame (2)** board's pre-drilled holes to match those of the **Headboard (1)**.

Secure the **Headboard (1)** to the **Bed Frame (2)** by using 2 pieces of **Bolt (B)** with 2 pieces of **Spring Washer (D)**, 2 pieces of **Arc Washer (C)** for the thicker **Bed Frame (2)**, and 2 pieces of **Bolt (A)** with 2 pieces of **Spring Washer (D)**, 2 pieces of **Arc Washer (C)** for the thinner **Bed Frame (2)**.

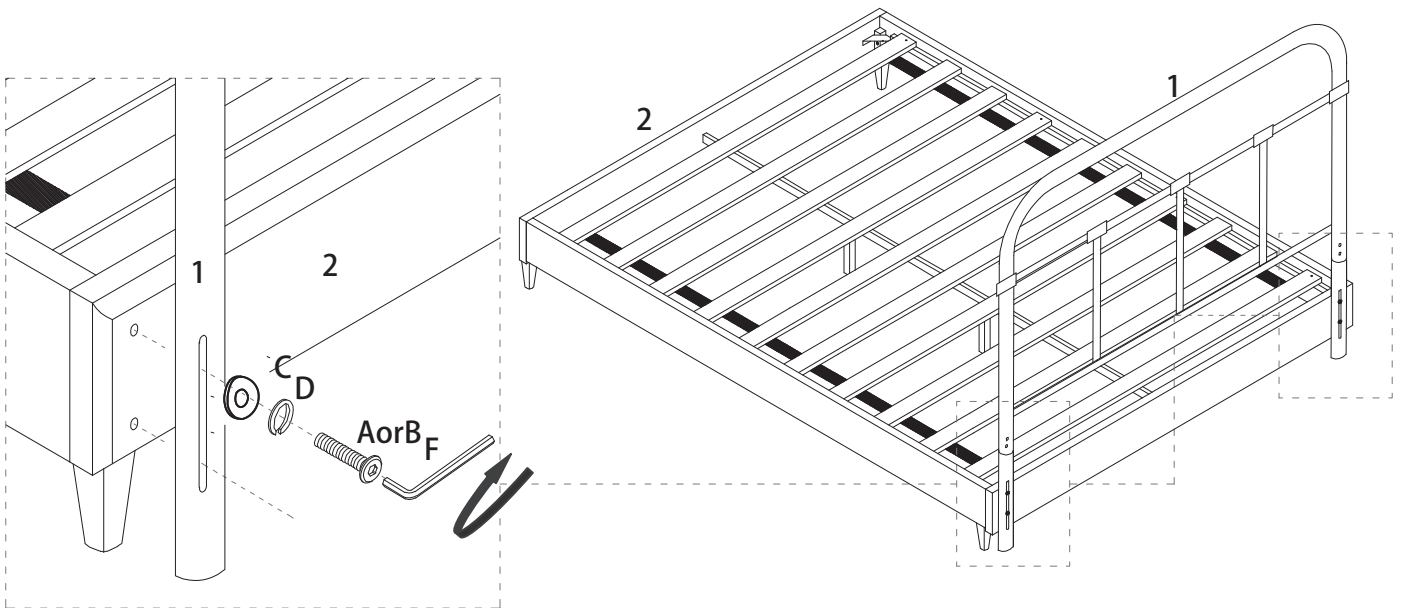
Then tighten the **Bolts (A or B)** by using the **Allen Wrench (F)**.

Repeat the same procedure for each bolt and each side of the **Bed Frame (2)**.



| | | | |
|---|---|---|---|
|  |  |  |  |
| A or Bx4 | Cx4 | Dx4 | Fx1 |

Hardware & Tool required

STEP 2:

Carefully position the assembled bed to the desired location by four adults.



Assembly is completed. The bed is ready to use now!

NOTE: Hardware may loosen over time. Periodically check that all connections are tight.