

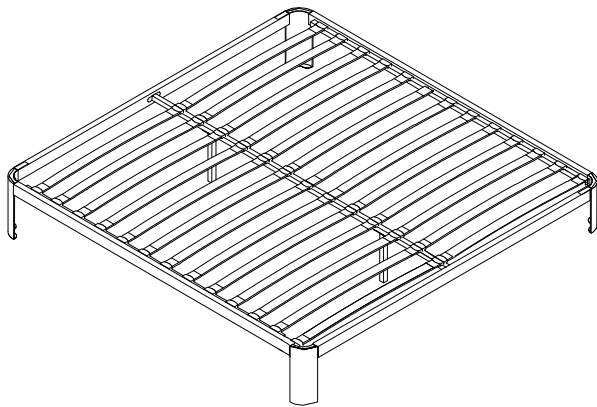





Thank you for purchasing the **MODWAY FULL BED FRAME!**

Before you start, here is some helpful advice:

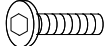
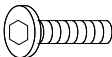
1. We suggest you spend a short time reading through this leaflet and then follow the simple step by step instructions.
2. Owing to the size and weight of the bed frame, we recommend that it is assembled by two adults, on a carpeted or padded area, in the room that it is intended for. Approx assembly time: 30 minutes.
3. Please do not use any tools other than those provided or recommended in these instructions.
4. Please do not throw away any of the packaging or the instruction until you have checked all the components and hardware and the furniture is fully assembled. Please ensure that the packaging is disposed of in a safe environmentally friendly way.
5. Assemble all components loosely until advised to tighten. Depending on use, it may be necessary to tighten the components from time to time, so please save the tools that has been provided.
6. Please keep all fitting out of reach of children.



Hardware:

A		Bolt M8x25mm	x16
B		Bolt M8x35mm	x4
C		Bolt M8x20mm	x4
D		Allen Wrench M5	x1
E		Open Wrench	x1
F		Side Plastic Cover	x24
G		Center Plastic Cover	x12
H		Nut M8	x4

Component:

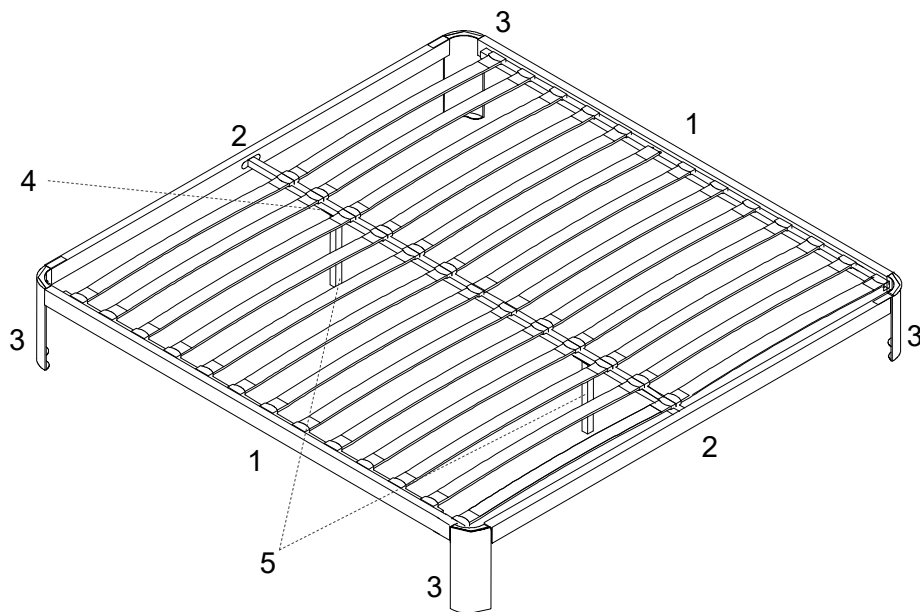

1	Long Board	x2	2	Short Board	x2	3	Leg	x4
4	Stretcher	x1	5	Support Leg	x2	6	Slat	x24

STEP 1:

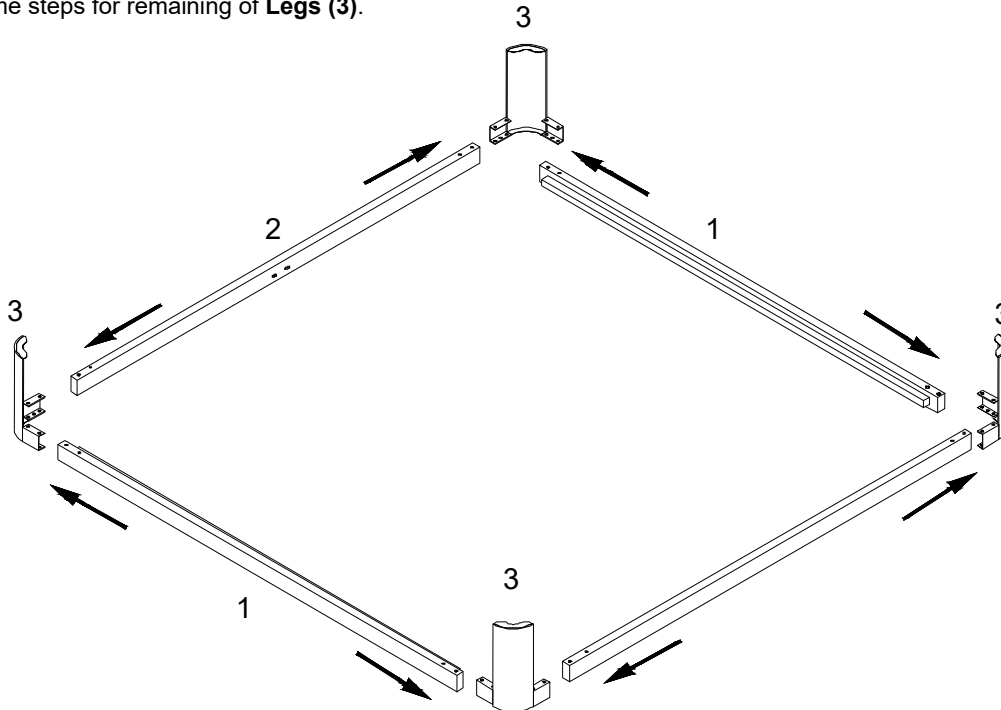

Place **Long Boards (1)**, **Short Boards (2)** and **Legs (3)** upside down on a carpeted or padded area. Insert the end of 1 piece of **Long Board (1)** and **Short Board (2)** into 1 piece of **Leg (3)** as shown. Repeat the same steps for remaining of **Legs (3)**.

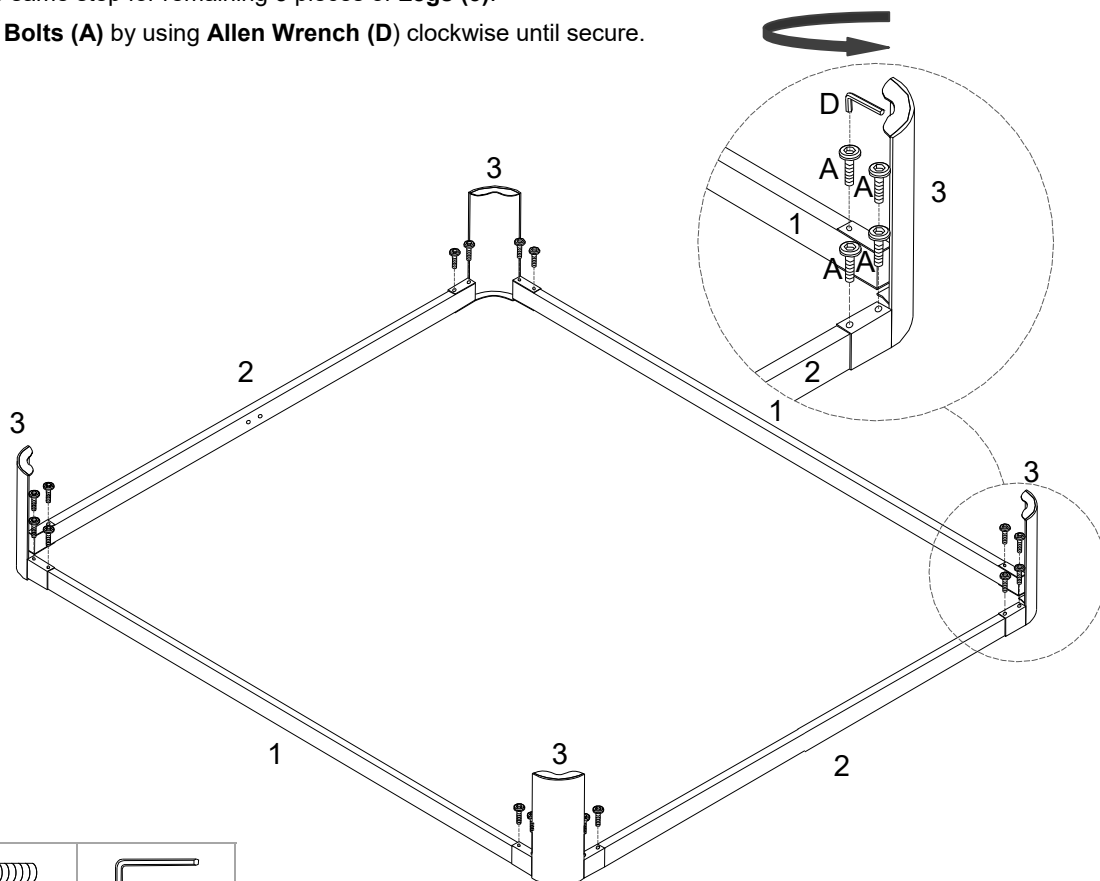

STEP 2:

Insert 4 pieces of **Bolt (A)** into the pre-dilled holes on **Leg (3)** through the pre-drilled holes on the end of **Long Board (1)** and **Short Board (2)** as shown. Repeat the same step for remaining 3 pieces of **Legs (3)**. Tighten all **Bolts (A)** by using **Allen Wrench (D)** clockwise until secure.



	
Ax16	Dx1

Hardware & Tool required

STEP 3:

Place **Stretcher (4)** to the assembled **Long Board (2)**.
 Secure each end of **Stretcher (4)** by using 2 pieces of **Bolt (C)** as shown.
 Tighten **Bolts (C)** by using **Allen Wrench (D)** clockwise until secure.
 Place 2 pieces of **Support Leg (5)** under the assembled **Stretcher (4)**.
 Secure each **Support Leg (5)** by using 2 piece of **Bolt (B)** and 2 pieces of **Nut (H)** as shown.
 Tighten **Bolts (B)** and **Nuts (H)** by using **Allen Wrench (D)** and **Open Wrench (E)** until secure.

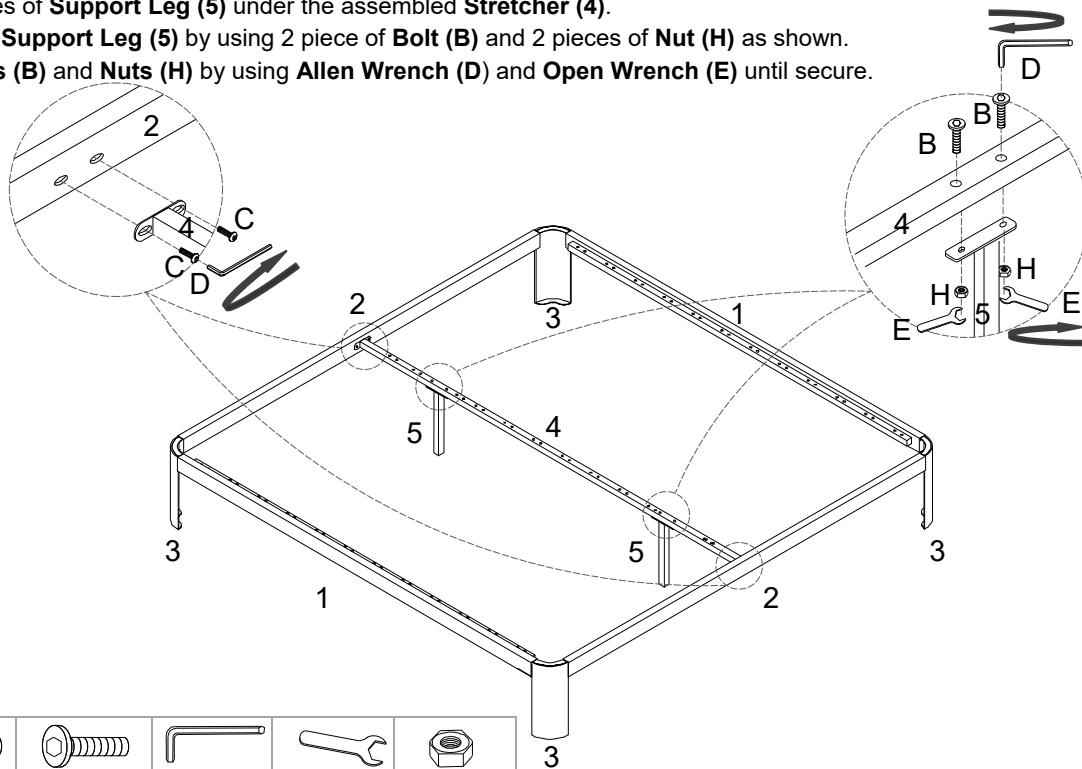

Bx4	Cx4	Dx1	Ex1	Hx4

Hardware & Tool required

STEP 4:

Insert 2 piece of **Side Plastic Cover (F)** into each end of 2 pieces of **Slat (6)** as shown.
 Insert the other end of the **Slats (6)** into 1 piece of **Center Plastic Cover (G)** as shown.
 Insert the assembled **Side Plastic Covers (F)** into the corresponding holes on **Long Board (1)**, and the assembled **Center Plastic Cover (G)** into the corresponding holes on **Center Rail (4)** as shown.
 Repeat the same steps for the remaining 22 pieces **Slat (6)**.

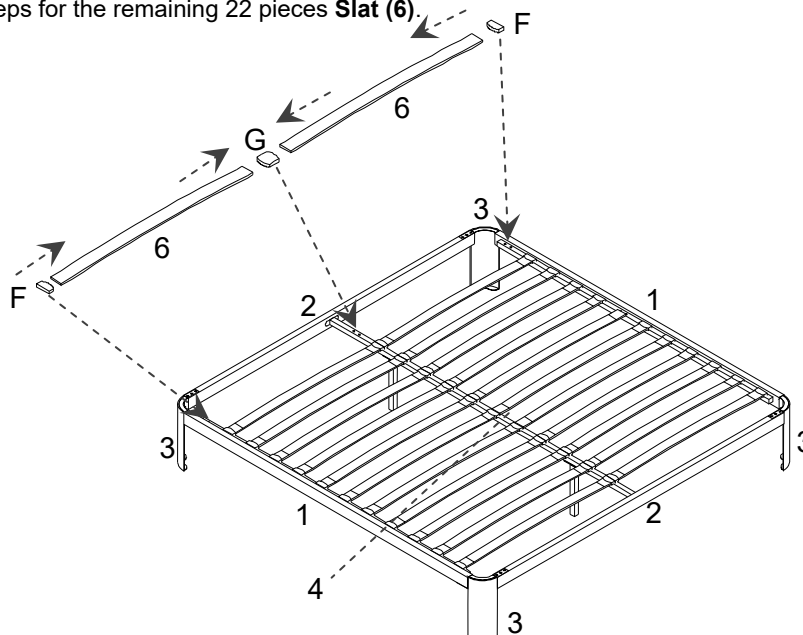

Assembly is complete. Your bed frame is ready to be enjoyed now!

Fx24	Gx12

Hardware & Tool required