

Windsor 47.24

Console Accent Table
4LC

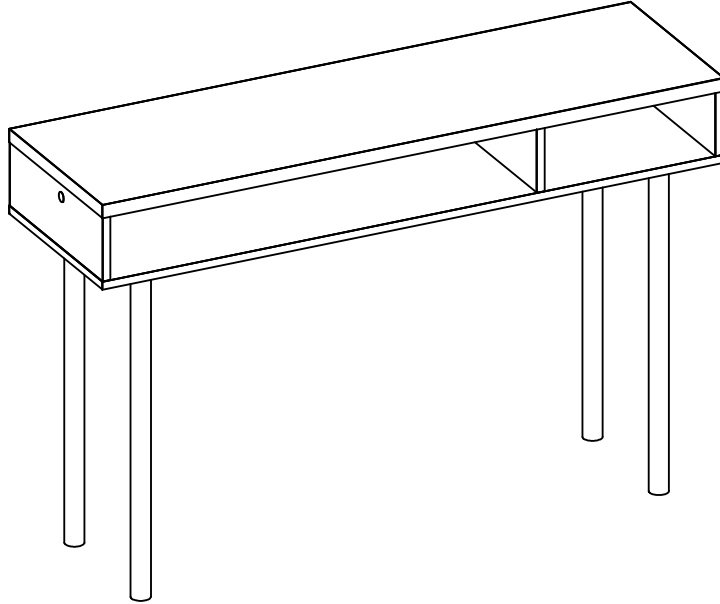

Dimensions/Dimensiones:

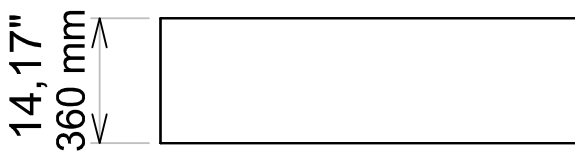
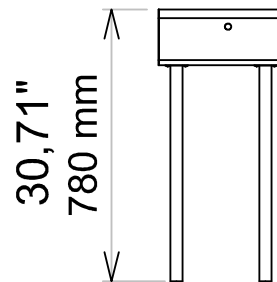
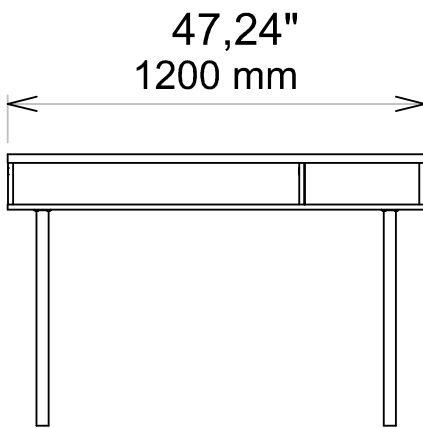

Assembly Instructions/
Instrucciones de Montaje.

Introduction / Introducción:

- *Read the manual and follow the steps for the perfect assembly.**
- *Prepare the environment before you start. Leave the room completely clean to start the assembly. Use the carton of the box as a protection layer to separate and protect the parts in order to avoid damages. Image 01.**
- *Don't install it in areas that may be damp, with infiltrations.**

*Observe cuidadosamente el manual y siga estrictamente los pasos de montaje.

*Antes de comenzar prepare el ambiente, dejando completamente limpio y con buen espacio para iniciar el montaje del producto. Utilice el cartón del propio embalaje, así como la protección de manta aislante para separar y apoyar las piezas retiradas de la caja. Forra el área de montaje con la manta aislante, así evita avería en la piezas durante el proceso de montaje, Image 01.

*No instalar en superficies húmedas, conyener infiltraciones.

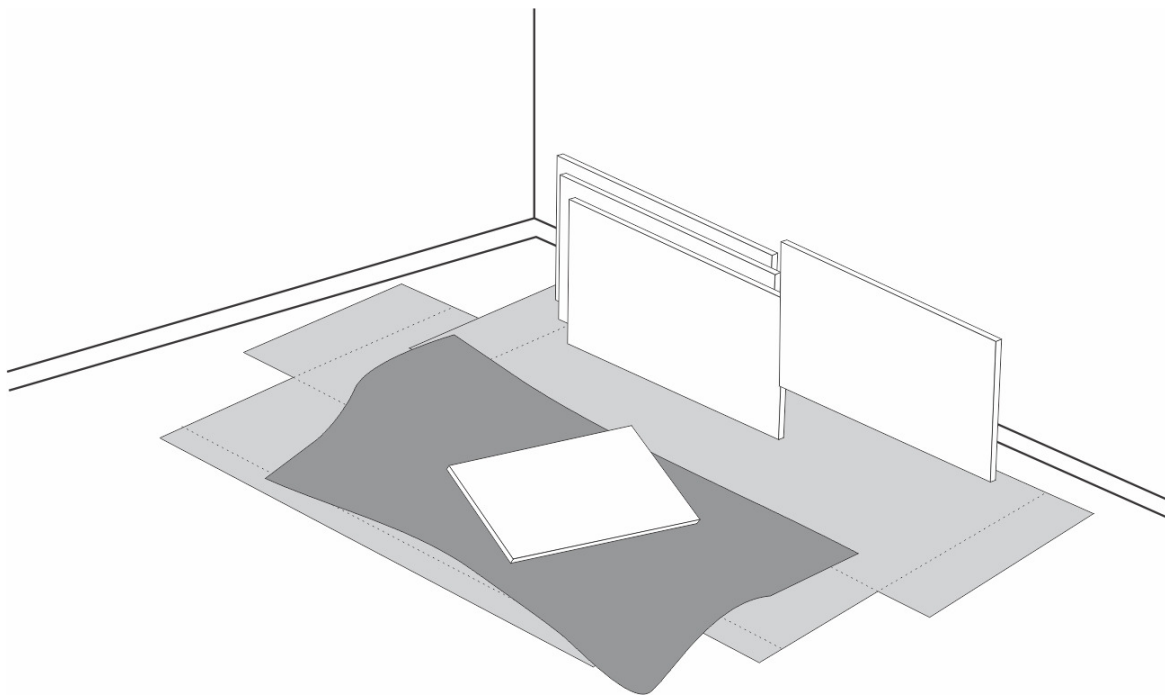

*Image 01 Separate the parts / Piezas separadas

*** Before beginning the assembly check all components with the parts list, separate hardware by type and assemble the furniture lying down.**

* Antes de comenzar el montaje compruebe todos los componentes con la lista de piezas, separe los herrajes por tipo e montar el móvil acostado.

*** The parts come with their code stamped on.**

* Los códigos de las pieza están sellados en las mismas.

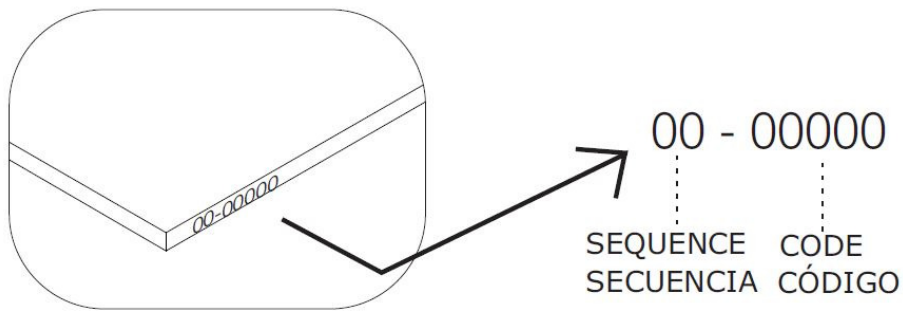

Tools / Herramientas

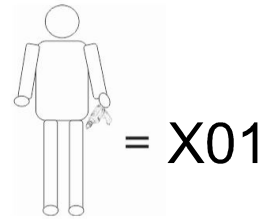
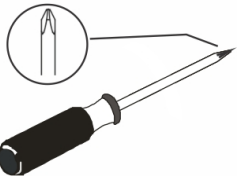

Hardwares / Accesorios



Ⓐ = X16



Ⓑ = X3



Ⓒ = X3

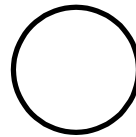

Ⓓ = X3



Ⓔ = X3





Ⓕ = X16

SECUENCIA	CODE	DESCRIPTION	QTY
01	50964	BASE	1
02	50966	LEFT SIDE	1
03	50968	BACKGROUND	1
04	50967	SIDE AND SPLIT	2
05	50965	TOP BOARD	1
06	00000	FOOT SUPORT	4
07	00000	CYLINDRICAL FOOT	4

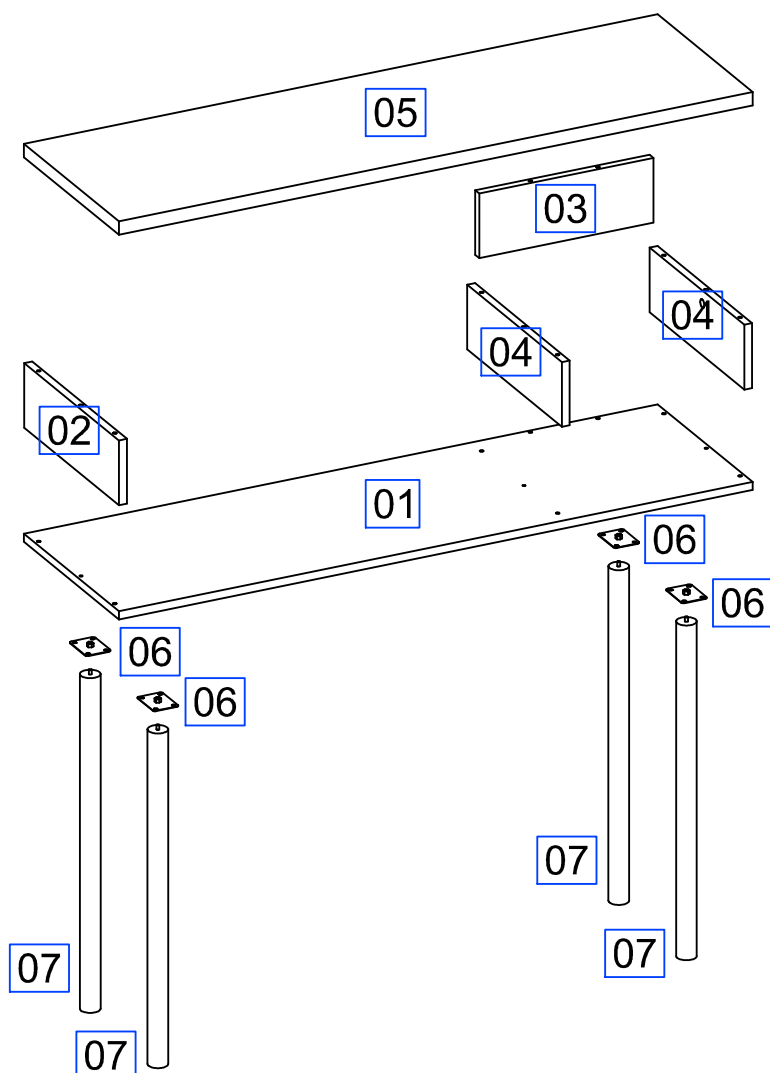
SECUENCIA	CÓDIGO	DESCRIPCIÓN	CANTIDAD
01	50964	BASE	1
02	50966	LATERAL IZQUIERDA	1
03	50968	FONDO	1
04	50967	LATERAL Y PARTICIÓN	2
05	50965	CUBIERTA	1
06	00000	SOPORTE PARA PIES	4
07	00000	PIE CILINDRICO	4



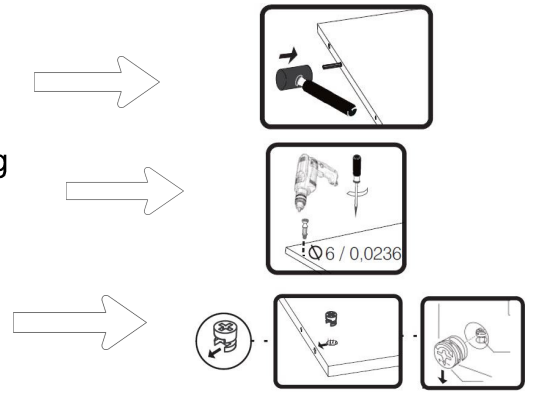

*** Before starting, you have to know:**

- () You should always fix the dowel until the end using a rubber hammer.
- () You must screw thi hardware using an eletric drilling machine or phillips screwdriver only in the 0,236 inches hole (the smaller hole).
- () Always fix this hardware with the arrow faced to the hole.



*** Antes de empezar, necesitas saber:**

- () Deves siempre fijar ese accesorio hasta el final usando un martillo de caucho
- () Deves siempre fijar ese accesorio usando un taladrador eléctrico o llave Phillips solamente en el agujero de 6mm.
- () Deves siempre fijar ese accesorio con la seta hacia el agujero

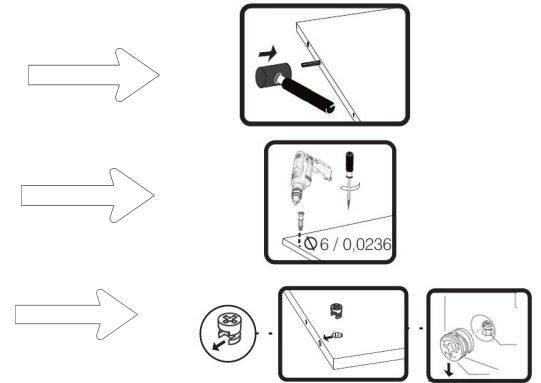

STEP / PASO 01

*** Insert hardware "A" on the extremities of the part 04 and hardware "C" on the face of it.**

X2

* Encaja los accesorios "A" en los extremos de las piezas "C" en las caras.

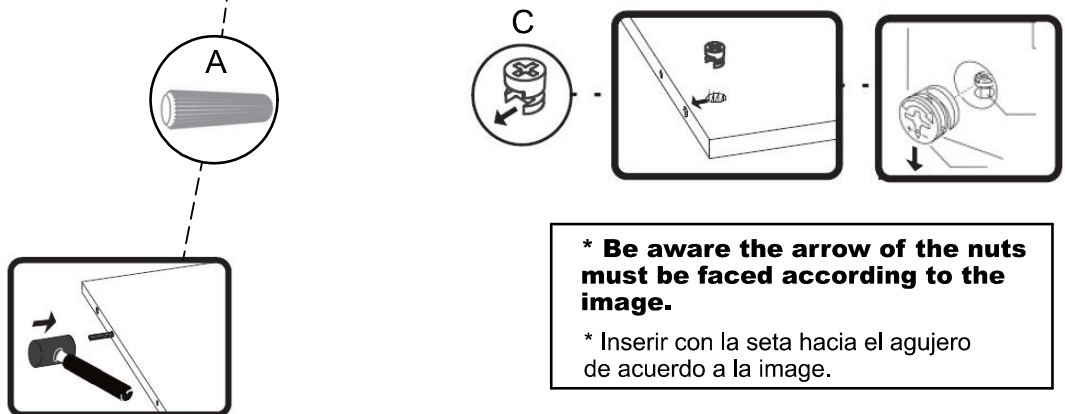
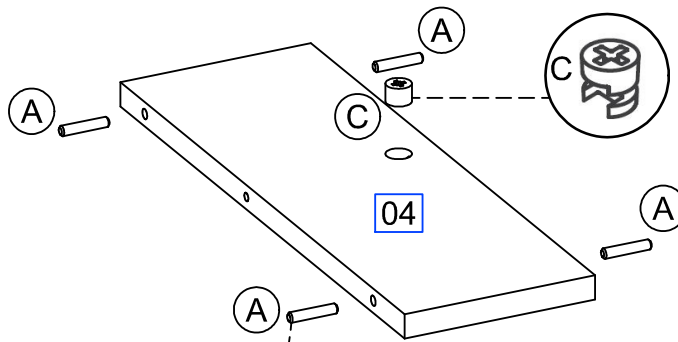

STEP / PASO 02

*** Insert accessory "A" into the extremity of part 03.**

* Encaja los accesorios "A" en las caras.

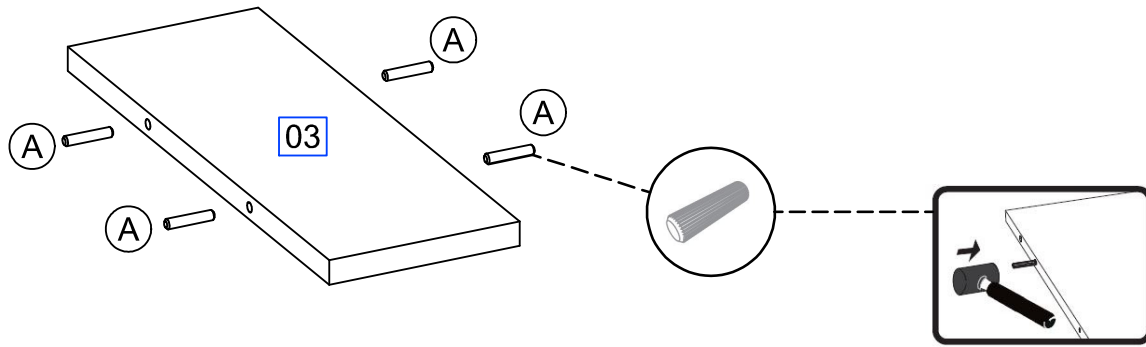

STEP / PASO 03

*** Insert hardware "A" on the extremities of the part 02 and hardware "C" on the face of it.**

* Encaja los accesorios "A" en los extremos de las piezas "C" en las caras.

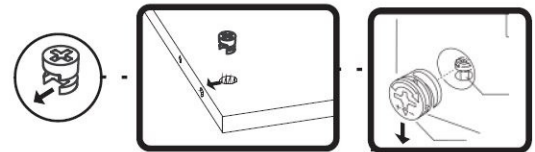
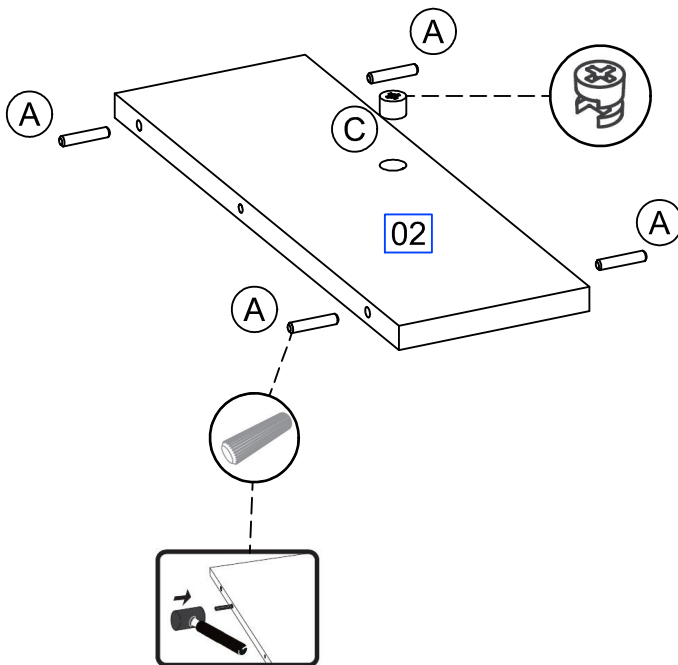

*** Be aware the arrow of the nuts must be faced according to the image.**

* Inserir con la seta hacia el agujero de acuerdo a la image.

STEP / PASO 04

*** Insert hardware "B" on the surface of part 05.**

* Encaja los accesorios "B" en las caras.

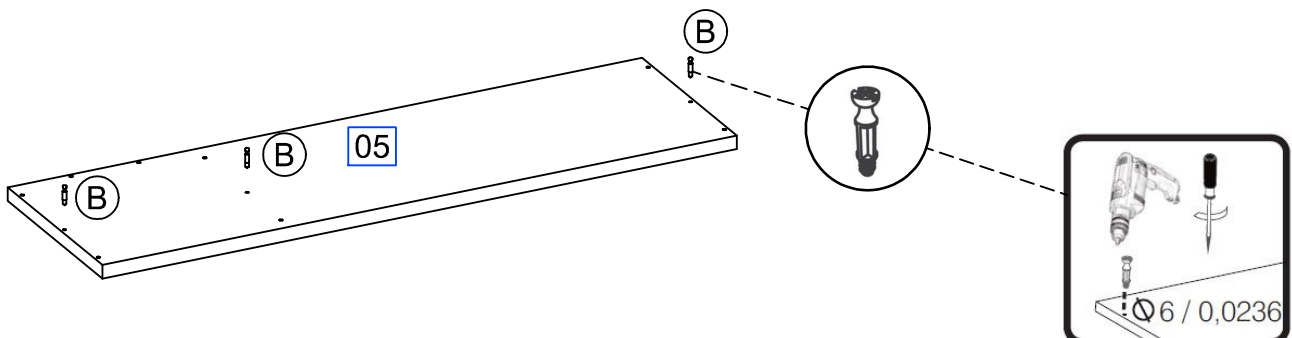

STEP / PASO 05

*** Attach part 02 to the part 01 according to the image, then screw it using hardware "E".**

* Enganche pieza 02, atornillar usando el accesorio "E".

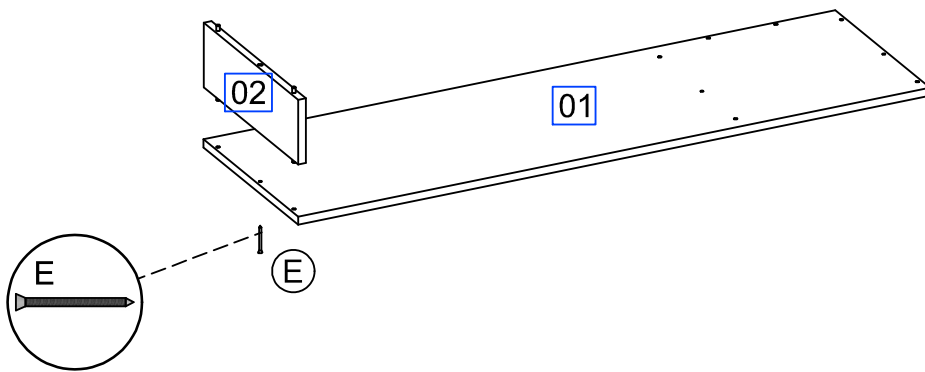

STEP / PASO 06

*** Attach part 03 according to the existing pre holes of part 01.**

* Enganche pieza 03, acuerdo las marcaciones existentes en el pieza 01.

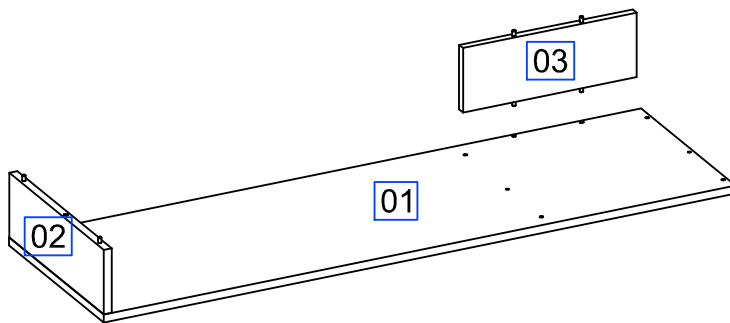

STEP / PASO 07

*** Attach part 04 to the part 01 according to the image, then screw it using hardware "E".**

* Enganche pieza 04, atornillar usando el accesorio "E".

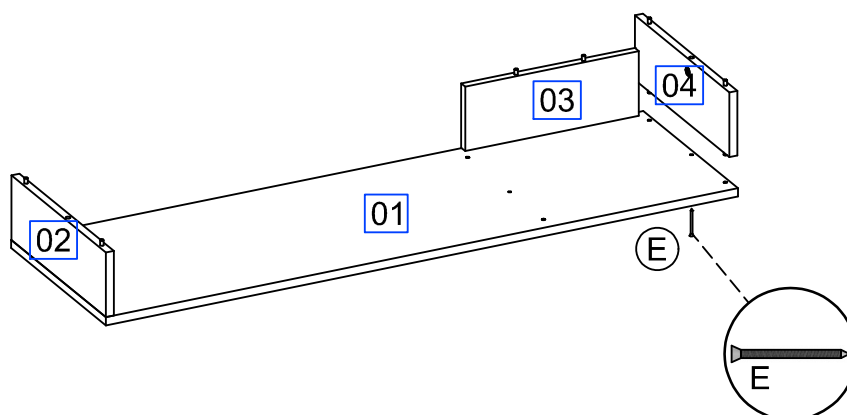

STEP / PASO 08

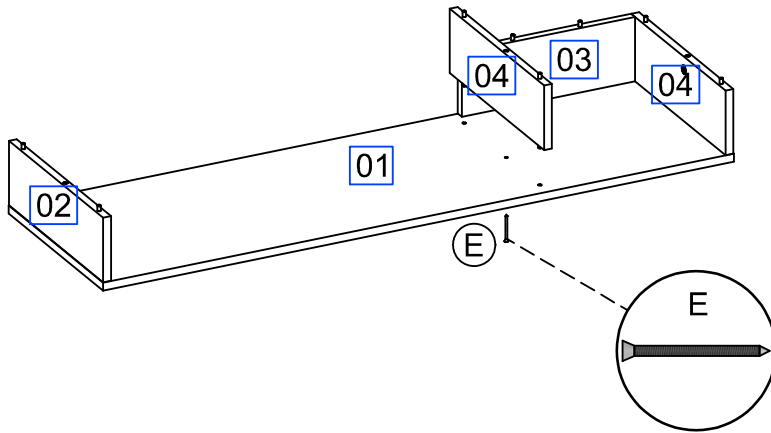

*** Attach part 04 to the part 01 according to the image, then screw it using hardware "E".**

* Enganche pieza 04, atornillar usando el accesorio "E".

STEP / PASO 09

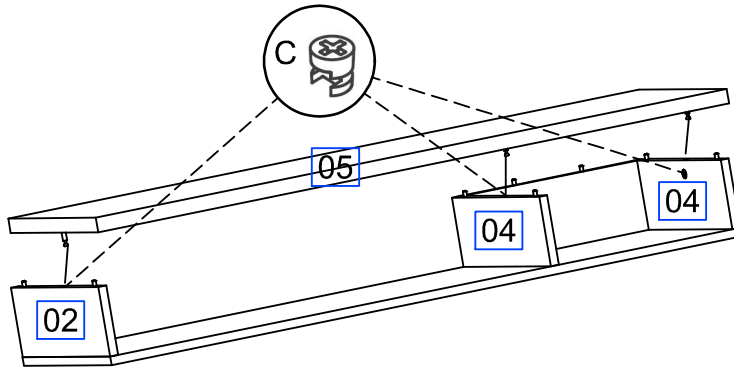

*** Attach part 05 to the parts 02 and 04 according to the image. Then screw them using the nuts "C".**

* Enganche pieza 05 en la piezas 02 y 04. Atonillar las tuercas.

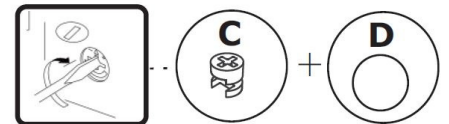

STEP / PASO 10

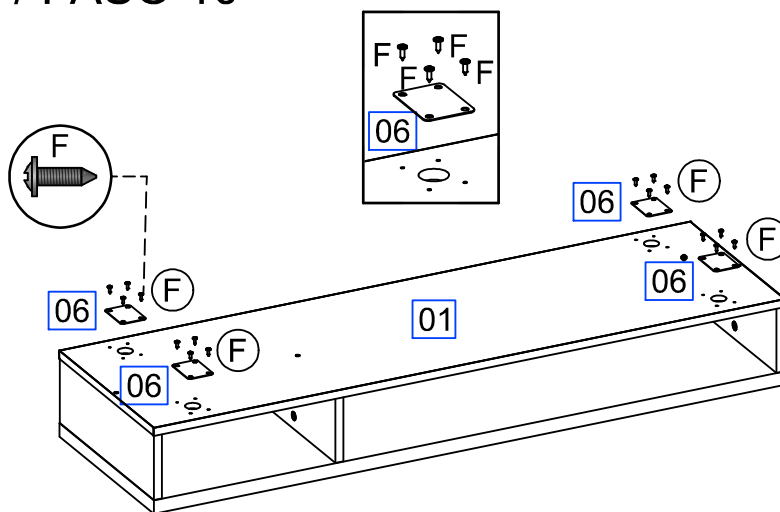

*** Screw the part 06, using the hardware "F" according to the existing pre holes of part 01.**

* Fijar pieza "06", usando accesorios "F", acuerdo las marcaciones existentes en el pieza.

STEP / PASO 11

*** Attach part 07 to the part 06 according to the image.**

* Enganche pieza 07 en la pieza 06, acuerdo con la imagen.

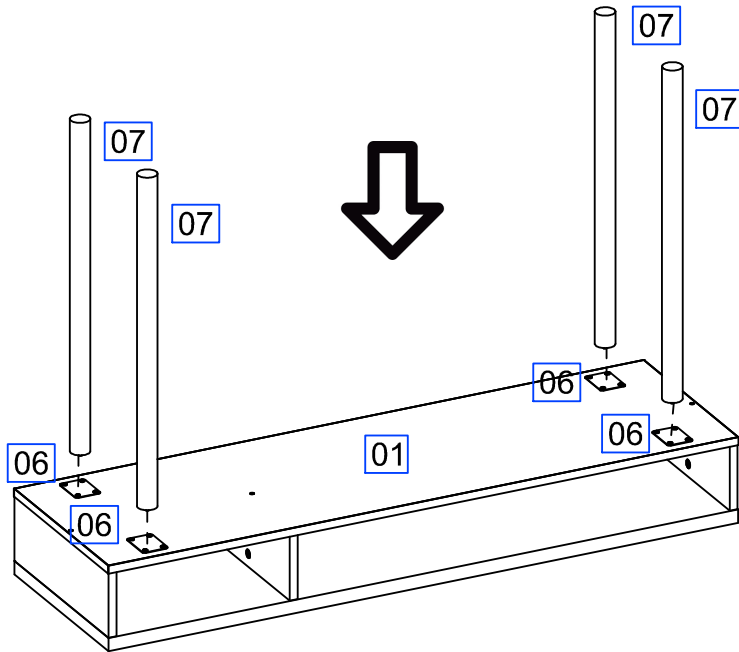

FINAL VIEW / ASPECTO FINAL

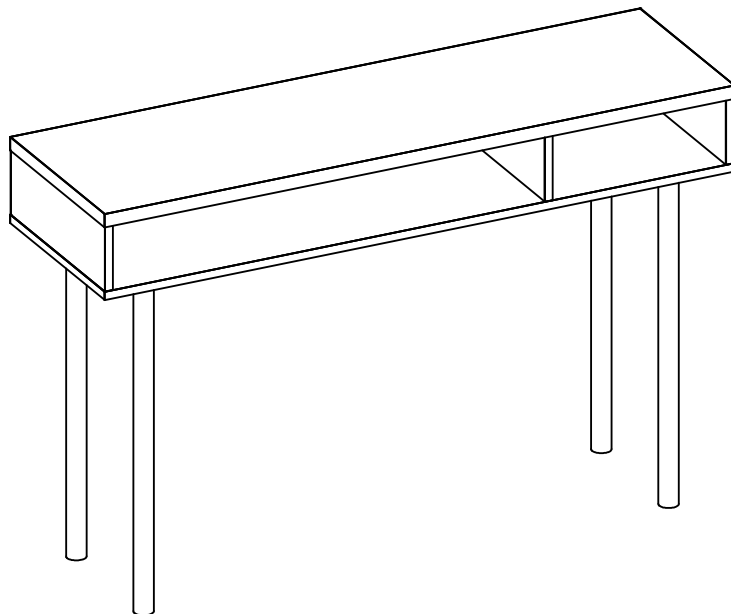

WEIGHT / PESO

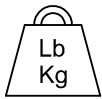

*** Be aware about maximum weights shown in the assembly instruction.**

* Todos los pesos máximos indicados en el manual deben ser respetados.

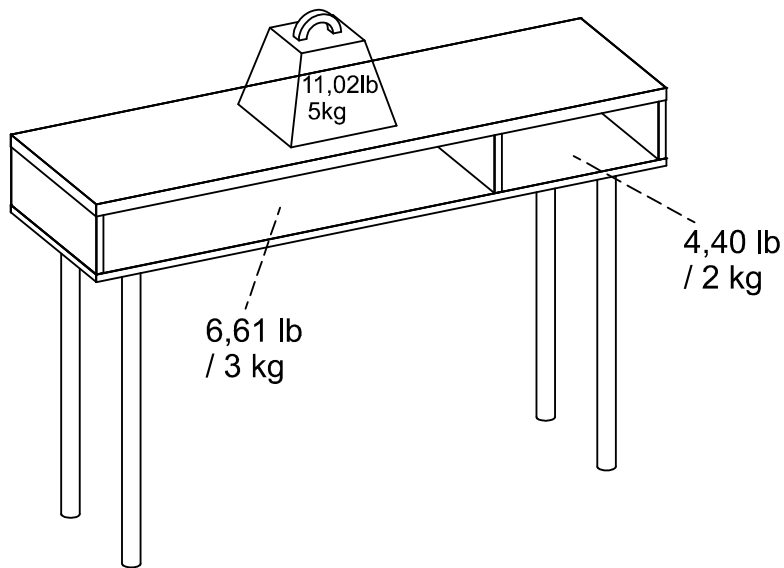

AVOID ACCIDENTS / PREVENIR ACCIDENTES

*** Don't climb or lean on the furniture.**

* No se suba ni se apoye en el mueble.

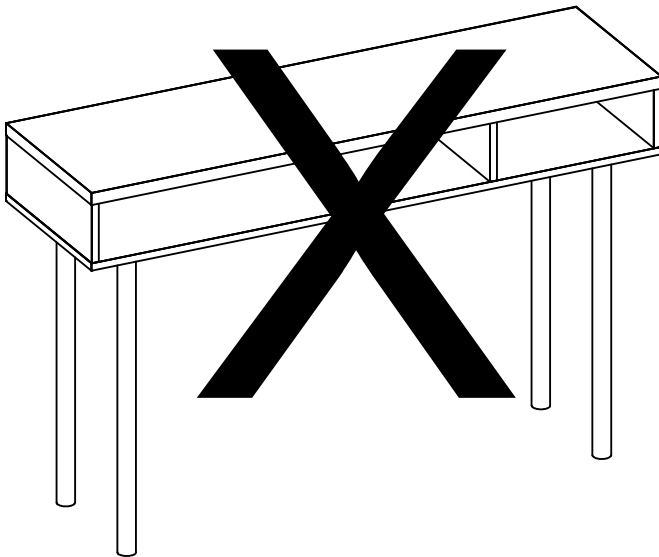

MAINTENANCE AND CLEANING / MANTENIMIENTO Y LIMPIEZA

*** For cleaning use only cloth slightly dampened in water.**

* Para la limpieza utilice sólo un paño húmedo con agua.

