

**MANUAL DE MONTAGEM
ASSEMBLY INSTRUCTIONS
INSTRUCCIONES DE MONTAJE**

**COD BR: BE 08-06, BE 08-164
COD US: 18AMC6, 18AMC130, 18AMC164**

Sumário Summary Resumen

Introdução Introduction Introducción	3
Antes de começar Before starting Antes de comenzar	4
Evite acidentes Avoid accidents Evitar accidentes	4
Dimensões e ferramentas Dimensions and tools Dimensiones y herramientas	5
Identificação das peças Identifying parts Identificación de las piezas	6
Acessórios incluídos na caixa Hardware included in box Accesorios incluidos en la caja	7
Montagem do móvel Furniture assembly Montaje del mueble	8

Introdução Introduction Introducción

Leia atentamente este manual e siga os passos indicados para uma perfeita montagem.
Read this manual and follow the steps for the perfect fit.
Lea este manual y siga los pasos para el ajuste perfecto.

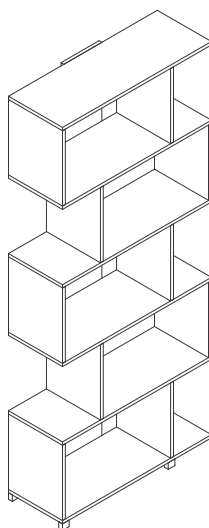

Antes de começar Before starting Antes de comenzar

Antes de começar a montagem prepare o ambiente, deixando-o completamente limpo e com bom espaço para iniciar o trabalho.

Prepare the room before starting the assembly, leaving it completely clean and the area in good condition to start the work.

Antes de comenzar el montaje preparar el ambiente, dejándolo completamente limpio y con bueno espacio para comenzar el trabajo.

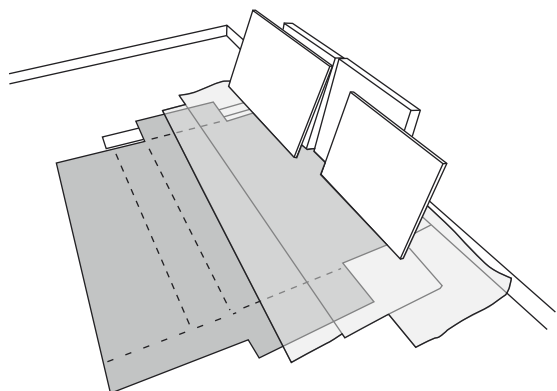

Utilize o papelão da própria embalagem para separar e apoiar as peças retiradas das caixas.

Use the cardboard of the packaging to separate and support the parts removed from the boxes.

Utilice el cartón de la embalaje para separar y apoyar las piezas desmontadas de las cajas.



Forre a área de montagem com um cobertor ou tapete. Assim, você evita avarias nas peças durante o processo de montagem.

Cover the assembly area with a blanket or carpet to avoid damaging the parts during the assembly process.

Cubrir la zona de ensamble con una manta o alfombra. De este modo, se evitan daños en las piezas durante el proceso de montaje.

Evite acidentes Avoid accidents Prevenir accidentes

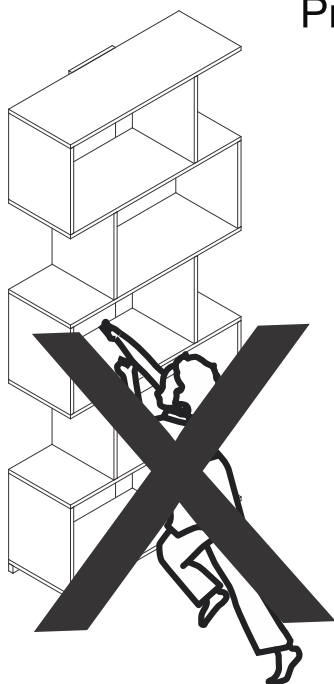

Não escale ou se apoie no móvel.

Do not climb or lean on the furniture.

No se suba ni se apoye en el mueble.

Dimensões e ferramentas
Dimensions and tools
Dimensiones y herramientas

Dimensões:

L: 785 A:1800 P: 310 mm

Dimensions:

W: 30.91 H: 72.44 D: 12.2 inches

Dimensiones:

L: 785 A: 1800 P: 310 mm

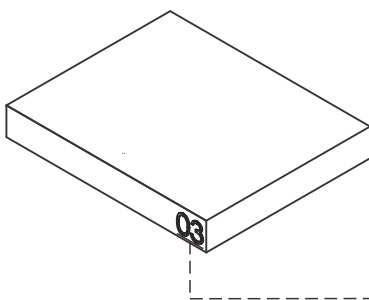
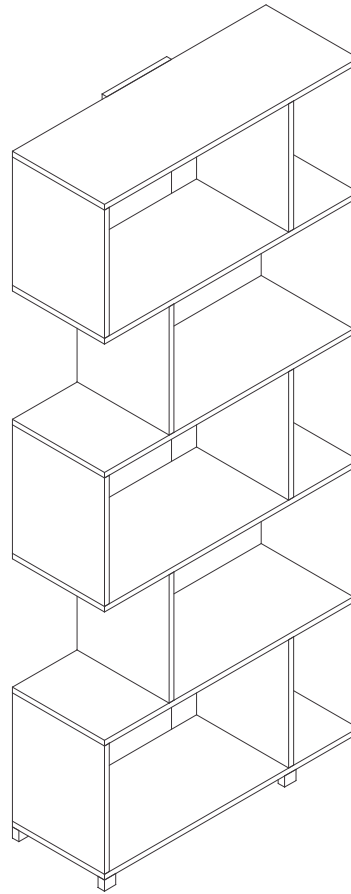

UTILIZE ALCOOL PARA REMOVER O NUMERO DAS PEÇAS
USE ALCOHOL TO REMOVE PART NUMBERS
UTILICE ALCOHOL PARA ELIMINAR EL NUMERO DE LAS PIEZAS

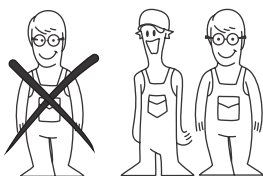

Para facilitar a montagem, utilize uma parafusadeira elétrica.
To improve assembly, use an electronic screwdriver.
Para facilitar el armado, utilice un destornillador eléctrico.

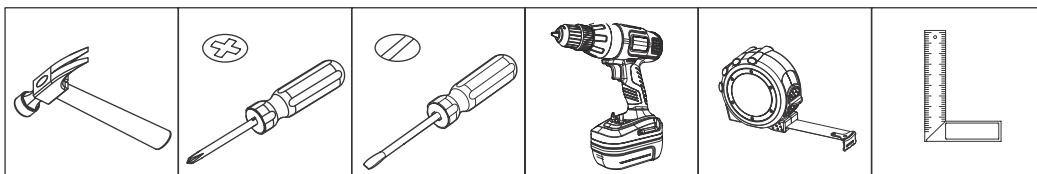

COD BR: BE 08-06, BE 08-164
 COD US: 18AMC6, 18AMC130, 18AMC164

PEÇA	DESCRIÇÃO	QUANT.	PART DESCRIPTION	QTY	PIEZA	DESCRIPCIÓN	CANTIDAD
001	LATERAL	10	001 SIDE	10	001	LATERAL	10
002	PRATELEIRA	4	002 SHELF	4	002	ESTANTE	4
003	TAMPO/BASE	2	003 TOP/BASE	2	003	TAPA/BASE	2
004	COSTA MAIOR	1	004 LONGER BACK	1	004	REVÉS MAYOR	1
005	COSTA MENOR	1	005 LOWER BACK	1	005	REVÉS MENOR	1

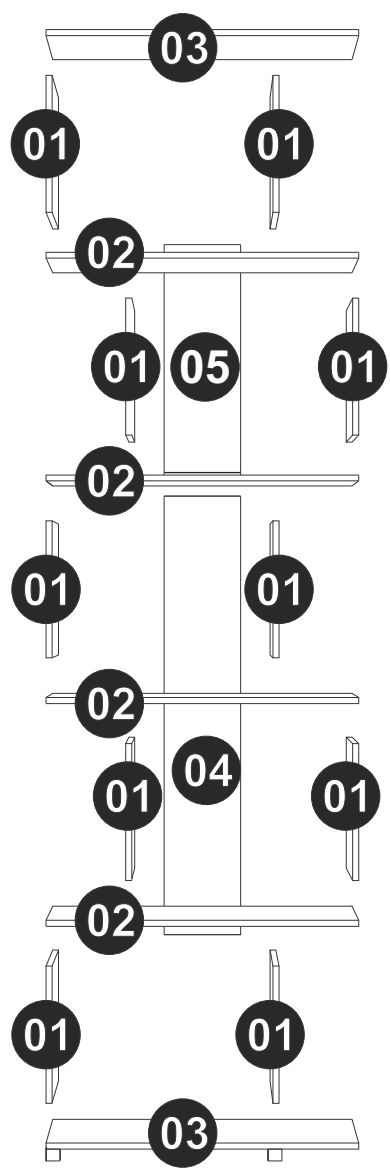

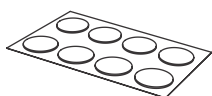

TAPA FUROS x 50
STICKER x 50
TAPAS PLÁSTICAS x 50



PÉS RETÂNGULARES x 4
RETANGULAR FEET x 4
PIES RECTANGULAR x 4



EF 000248 x 1



EF 000033 x 40

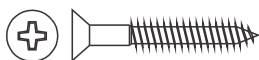

EF 000404 X 8



EF 000132 x 51

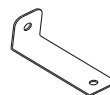

EF 000529 X 1



GIZ x 01
CHALK x 01
TIZA x 01



EF 000015 X 1



EF 000724 x 2

A = 2KG - 4.41LB

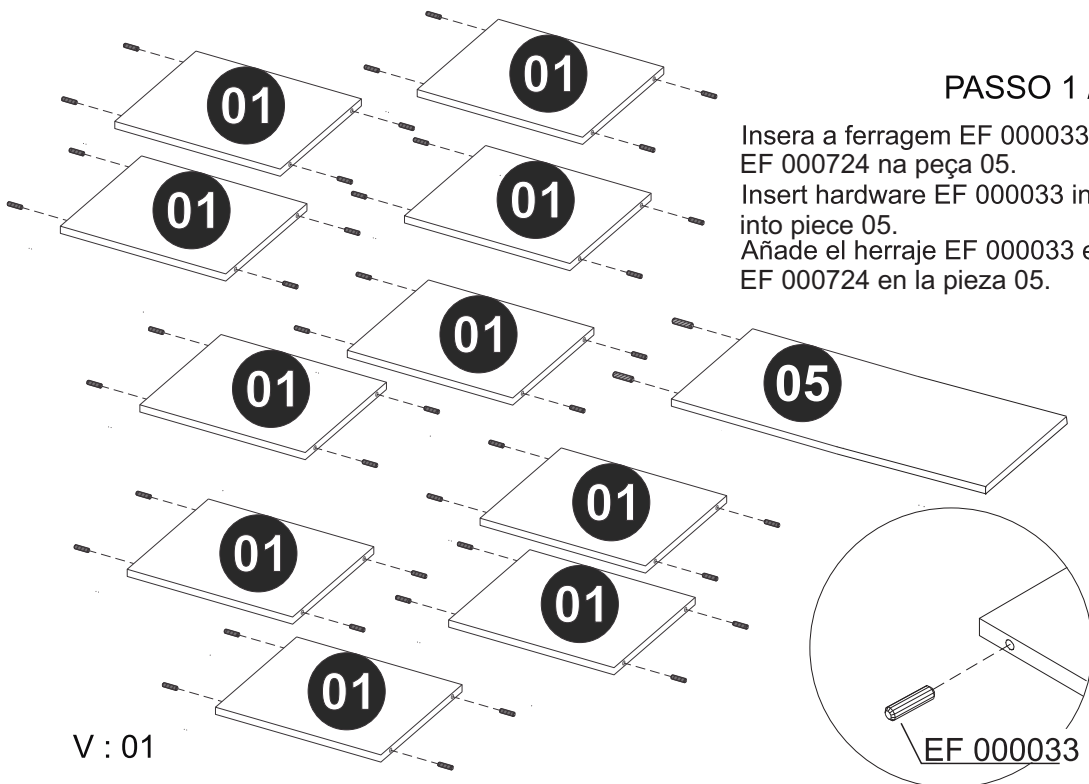
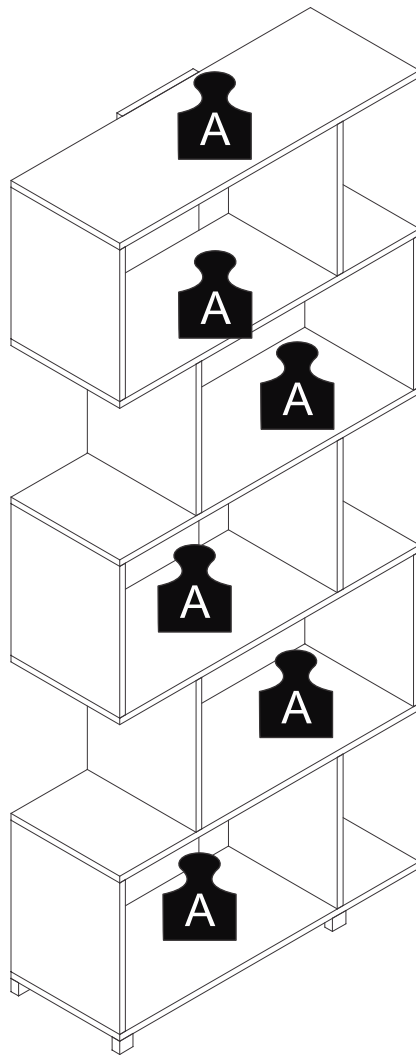

PASSO 1 / STEP 1 / PASO 1

Insera a ferragem EF 000033 nas peças 01. Insira a ferragem EF 000724 na peça 05.
Insert hardware EF 000033 into pieces 01. Insert hardware EF 000724 into piece 05.
Añade el herraje EF 000033 en las piezas 01. Añade el herraje EF 000724 en la pieza 05.

PASSO 2 / STEP 2 / PASO 2

Conecte as peças 01, 02 e 03 utilizando a ferragem EF 000132.
Connect pieces 01, 02 and 03 using hardware EF 000132.
Junte las piezas 01, 02 y 03 utilizando el herraje EF 000132.

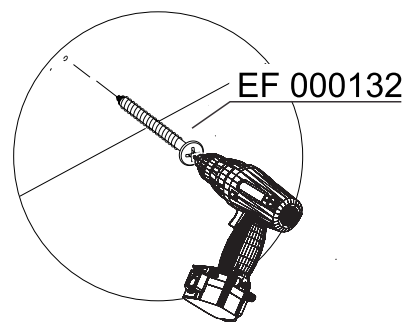
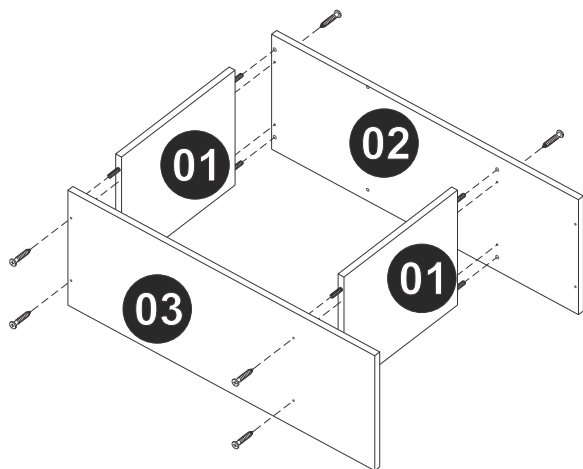

PASSO 3 / STEP 3 / PASO 3

Conecte as peças 01 e 02 à parte montada no passo anterior utilizando a ferragem EF 000132.
Connect piece 01 and 02 to the part assembled in the previous step using hardware EF 000132.
Junte la pieza 01 y 02 a la parte armada en el paso anterior utilizando el herraje EF 000132.

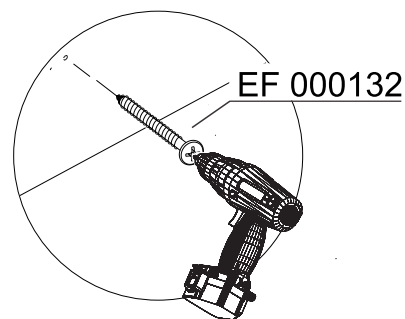
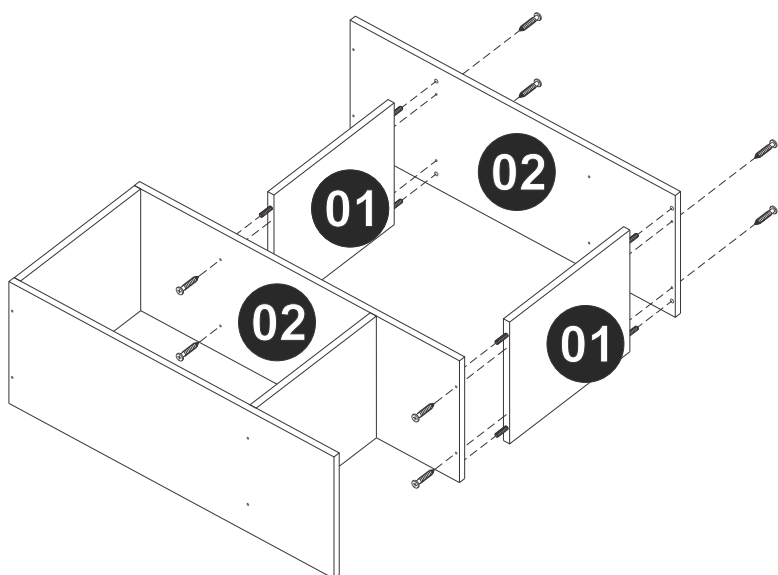

PASSO 4 / STEP 4/ PASO 4

Conecte as peças 01 e 02 à parte montada no passo anterior utilizando a ferragem EF 000132.
Connect piece 01 and 02 to the part assembled in the previous step using hardware EF 000132.
Junte la pieza 01 y 02 a la parte armada en el paso anterior utilizando el herraje EF 000132.

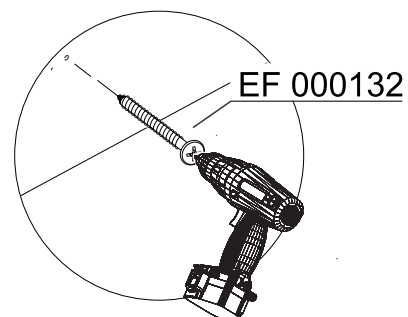
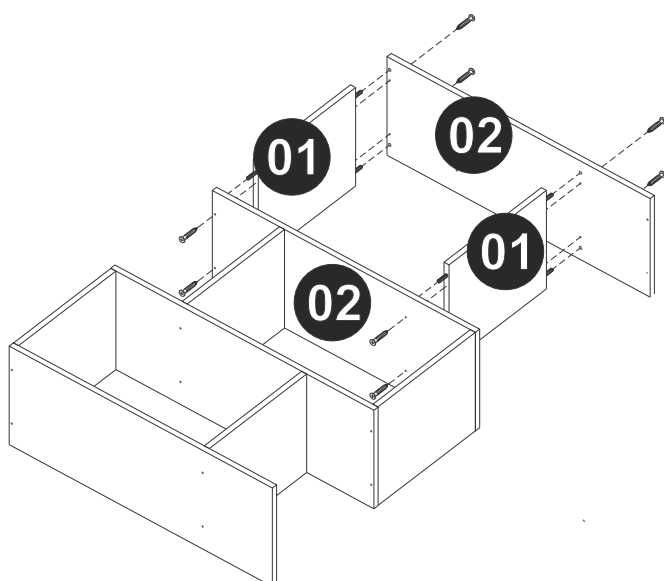

PASSO 5 / STEP 5 / PASO 5

Conecte as peças 01 e 02 à parte montada no passo anterior utilizando a ferragem EF 000132.

Connect piece 01 and 02 to the part assembled in the previous step using hardware EF 000132.

Junte la pieza 01 y 02 a la parte armada en el paso anterior utilizando el herraje EF 000132.

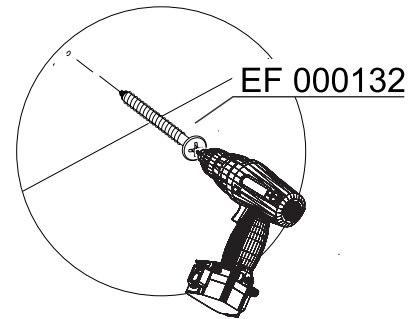
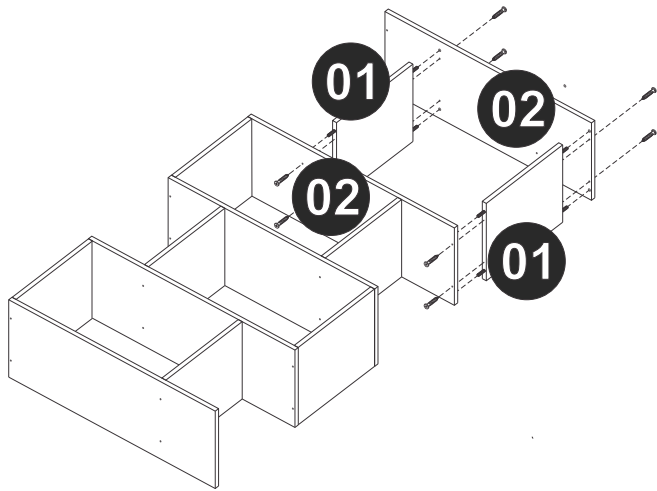

PASSO 6 / STEP 6 / PASO 6

Conecte as peças 01 e 03 à parte montada no passo anterior utilizando a ferragem EF 000132.

Connect piece 01 and 03 to the part assembled in the previous step using hardware EF 000132.

Junte la pieza 01 y 03 a la parte armada en el paso anterior utilizando el herraje EF 000132.

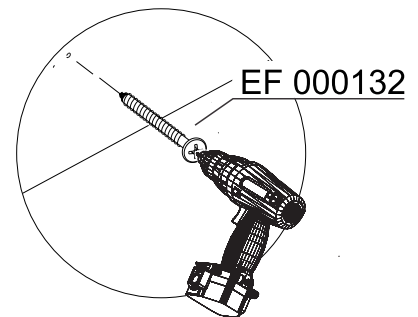
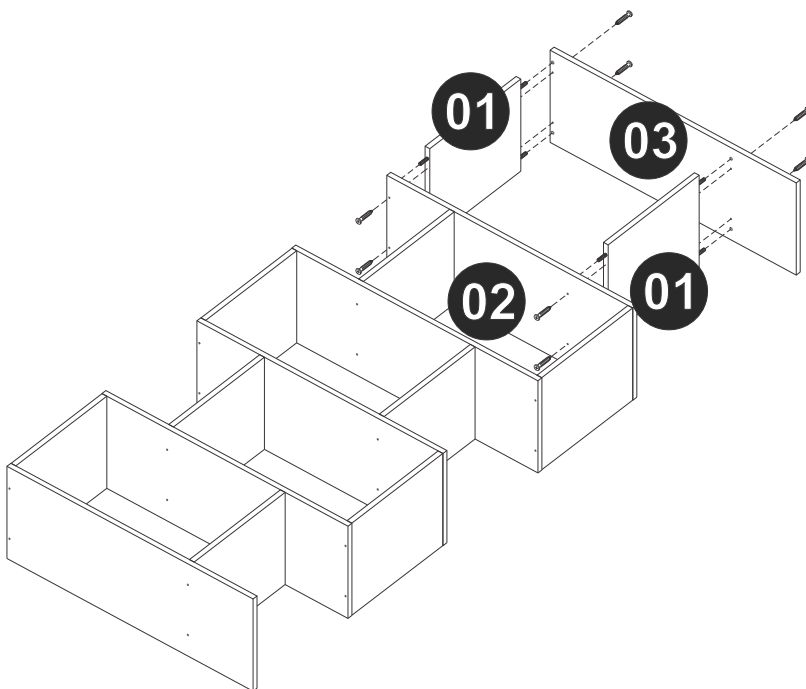

PASSO 7 / STEP 7 / PASO 7

Encaixe as peças 04 e 05, de acordo com a imagem.

Fit pieces 04 and 05, according the image.

Junte las piezas 04 y 05, de acuerdo con la imagen.

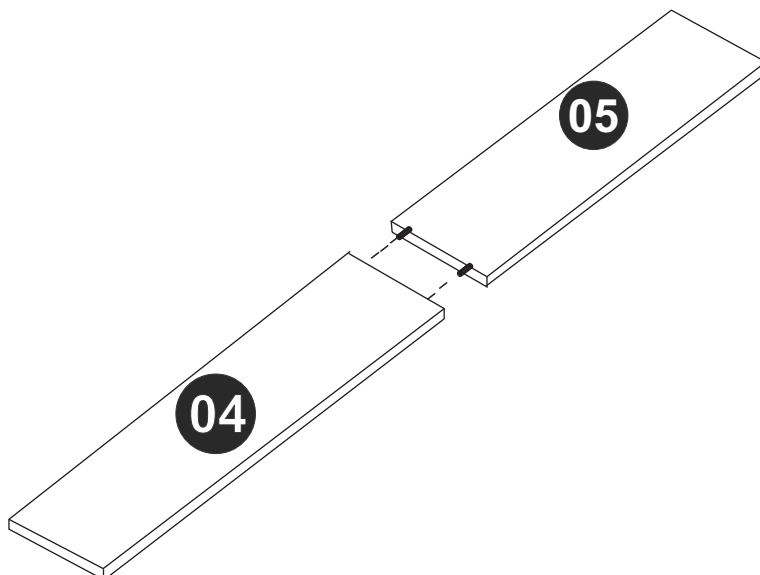

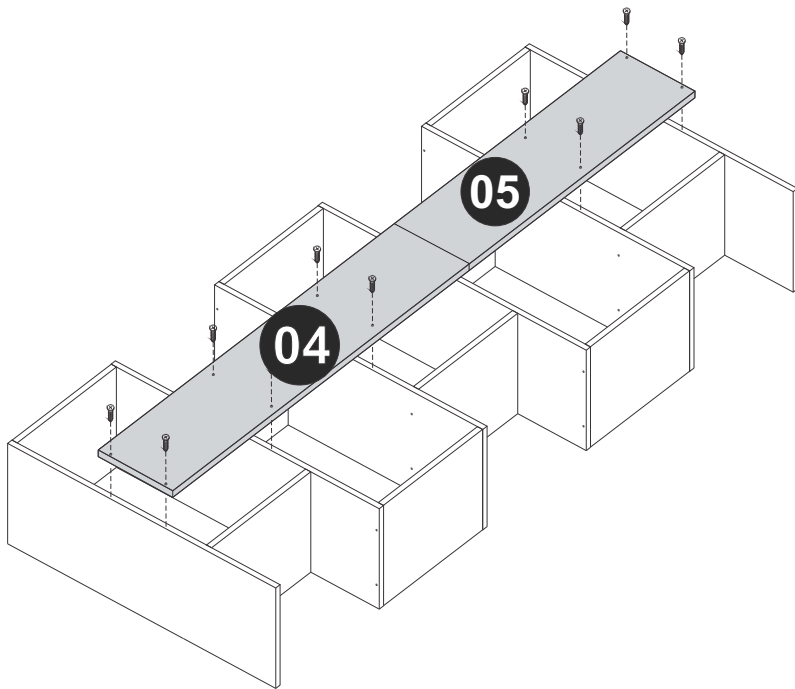

PASSO 8 / STEP 8 / PASO 8

Fixe as peças 04 e 05 utilizando a ferragem EF 000132.
 Fix pieces 04 and 05 using hardware EF 000132.
 Fije las piezas 04 y 05 utilizando el herraje EF 000132.

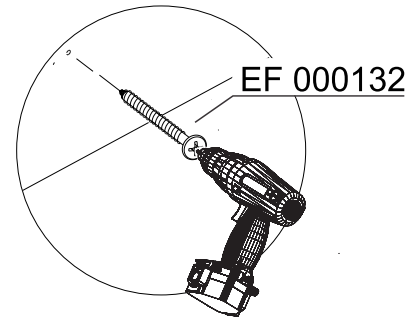

PASSO 9 / STEP 9 / PASO 9

Fixe os pés retangulares utilizando a ferragem EF 000404.
 Fix the rectangular feet using hardware EF 000404.
 Fije los pies rectangulares utilizando el herraje EF 000404.

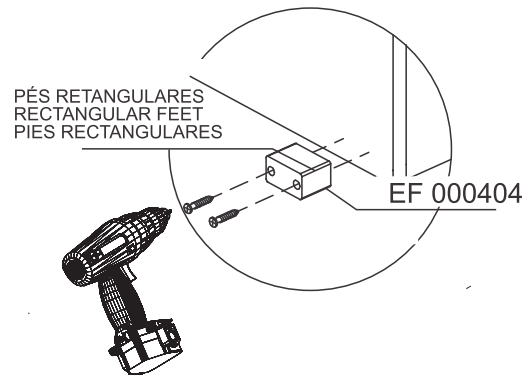
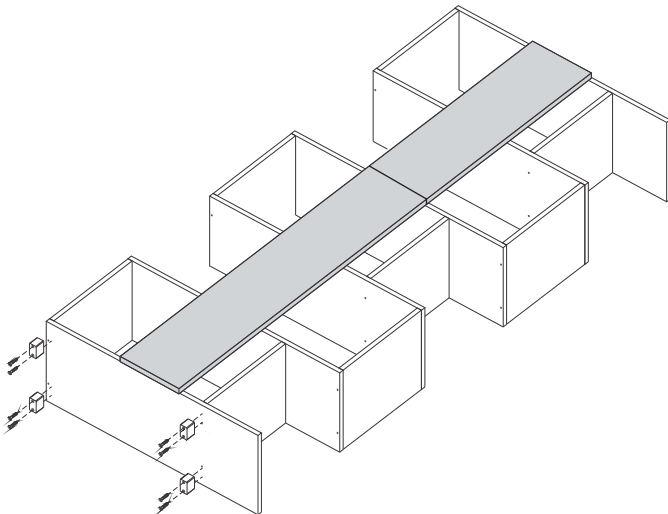

PASSO 10 / STEP 10 / PASO 10

Use o parafuso EF 000248 para fixar ferragem EF 000529 ao móvel.
 Use screw EF 000248 to fix hardware EF 000529 at the furniture.
 Utilice el tornillo EF 000248 para fijar el herraje EF 000529 al mueble.

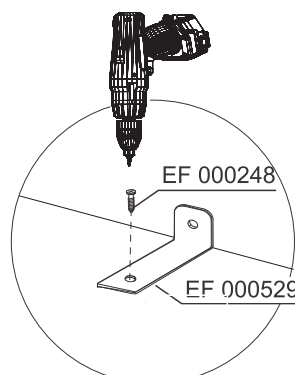
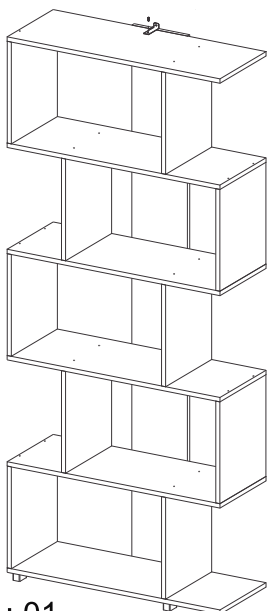

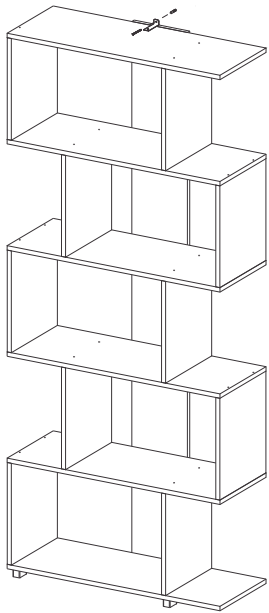

PASSO 11 / STEP 11/ PASO 11

Use as ferragens EF 000132 e EF 000015 para fixar o móvel na parede.
Use hardwares EF 000132 and EF 000015 for fixing the furniture on the wall.
Utilice los herrajes EF 000132 y EF 000015 para fijar el mueble en la pared.

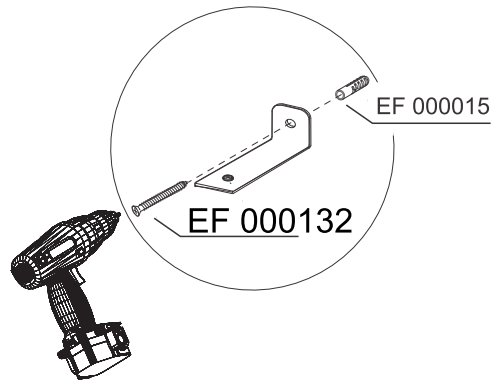

PASSO 12 / STEP 12 / PASO 12

Use os tapa furos para cobrir os parafusos aparentes.
Use stickers to cover apparent screws.
Utilice los tapa huecos para cubrir los tornillos aparentes.

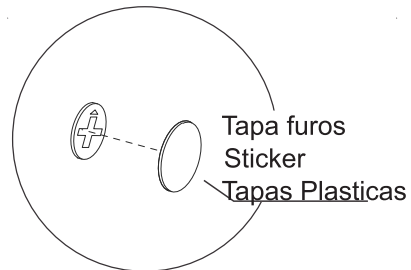
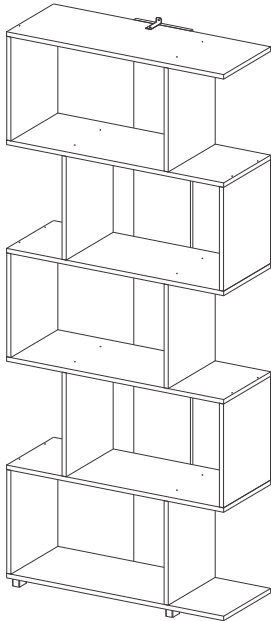

PASSO 13 / STEP 13 / PASO 13

Use o giz para dar o acabamento final ao produto.
Use the chalk to give the final finish on the product.
Utilice la tiza para dar el acabado final al producto.

