

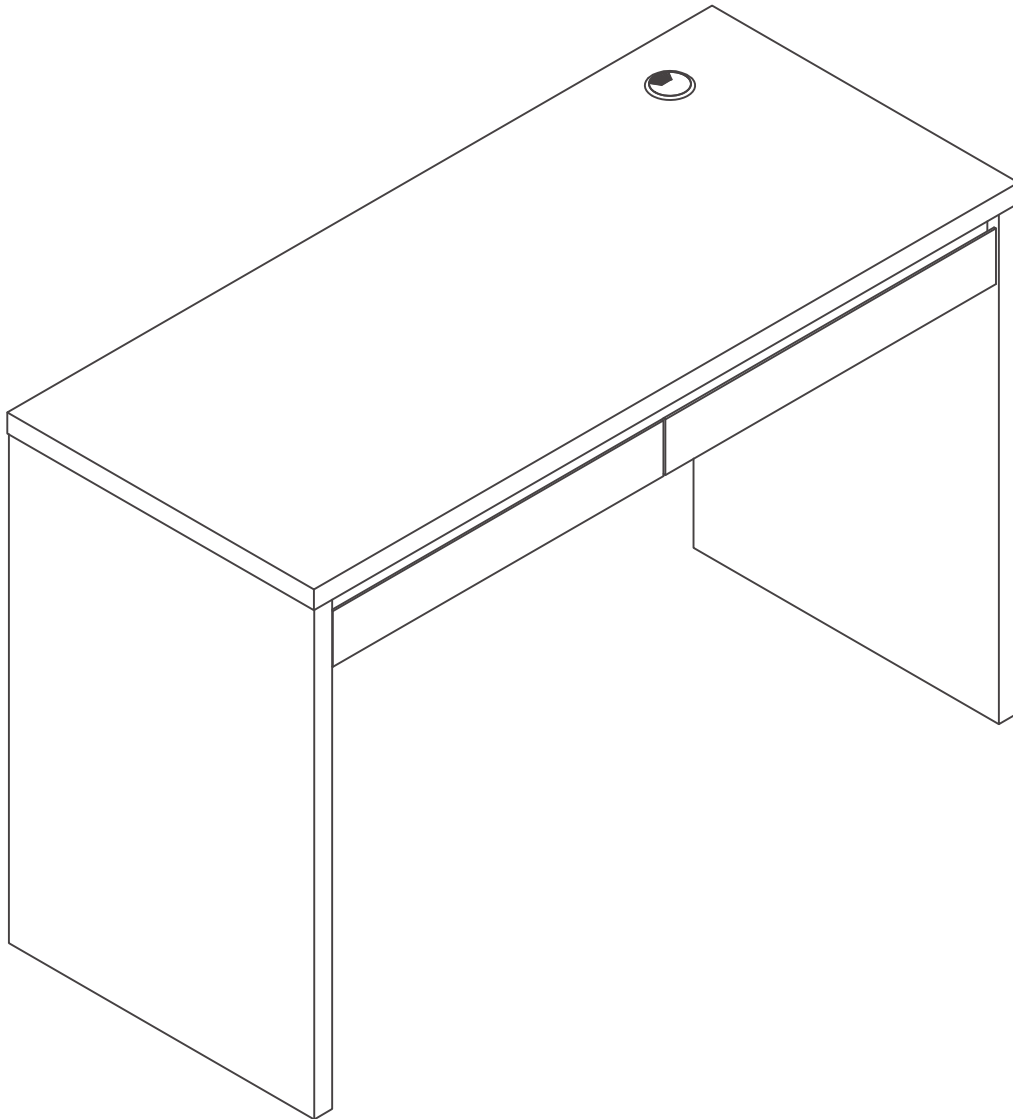

DESK
BUREAU
ESCRITORIO



GOC-20437

WE ARE HERE TO HELP!

BEFORE YOU RETURN IT - CONTACT US.

We do our best to insure that your furniture arrives in excellent condition. In the event that a part is damaged or missing, Linon will be happy to provide you with replacement parts, at no charge, within 30 days of purchase, providing the parts are available in our warehouse and the item purchased is part of our current inventory. In order to receive spare parts, at no charge, you must provide proof of purchase within 30 days.

For further information, please contact our customer service department, c/o Linon Home Décor Products, Inc., between 9:00 AM and 5:00 PM EST, Monday through Friday.

Email address: consumersupport@linon.com

NOUS SOMMES LÀ POUR VOUS AIDER!

AVANT DE RETOURNER LE PRODUIT, VEUILLEZ COMMUNIQUER AVEC NOUS.

Nous faisons tout en notre pouvoir pour que vous receviez votre meuble en parfait état. Toutefois, si une pièce est endommagée ou manquante, Linon se fera un plaisir de vous envoyer gratuitement la pièce de rechange, dans les 30 jours suivant l'achat, à condition que nous ayons la pièce en stock et que le produit acheté fasse partie de notre inventaire courant. Afin de recevoir gratuitement la pièce de rechange, vous devez fournir une preuve d'achat dans un délai de 30 jours.

Pour de plus amples renseignements, veuillez communiquer avec notre département du service à la clientèle, entre 9 h et 17 h HNE, du lundi au vendredi.

Adresse de courriel : consumersupport@linon.com

¡ESTAMOS AQUÍ PARA AYUDARLE!

ANTES DE REGRESAR EL PRODUCTO, COMUNÍQUESE CON NOSOTROS.

Hacemos todo lo posible para que su mobiliario se le entregue en excelentes condiciones. En caso de que falte una pieza o esté dañada, Linon le enviará con gusto la pieza de repuesto sin ningún costo dentro de los 30 días posteriores a la compra, siempre y cuando tengamos en existencia las piezas en nuestros almacenes y que el artículo comprado forme parte de nuestro inventario actual. Para recibir piezas de repuesto, sin costo adicional, debe enviarnos el comprobante de compra dentro de los 30 días después de la compra.

Si desea más información, póngase en contacto con nuestro departamento de servicio al cliente, de lunes a viernes entre las 9:00 a.m. y las 5:00 p.m., hora estándar de los Estados Unidos.

Correo electrónico: consumersupport@linon.com

PART LIST / LISTE DES PIÈCES / LISTAS DE PIEZAS

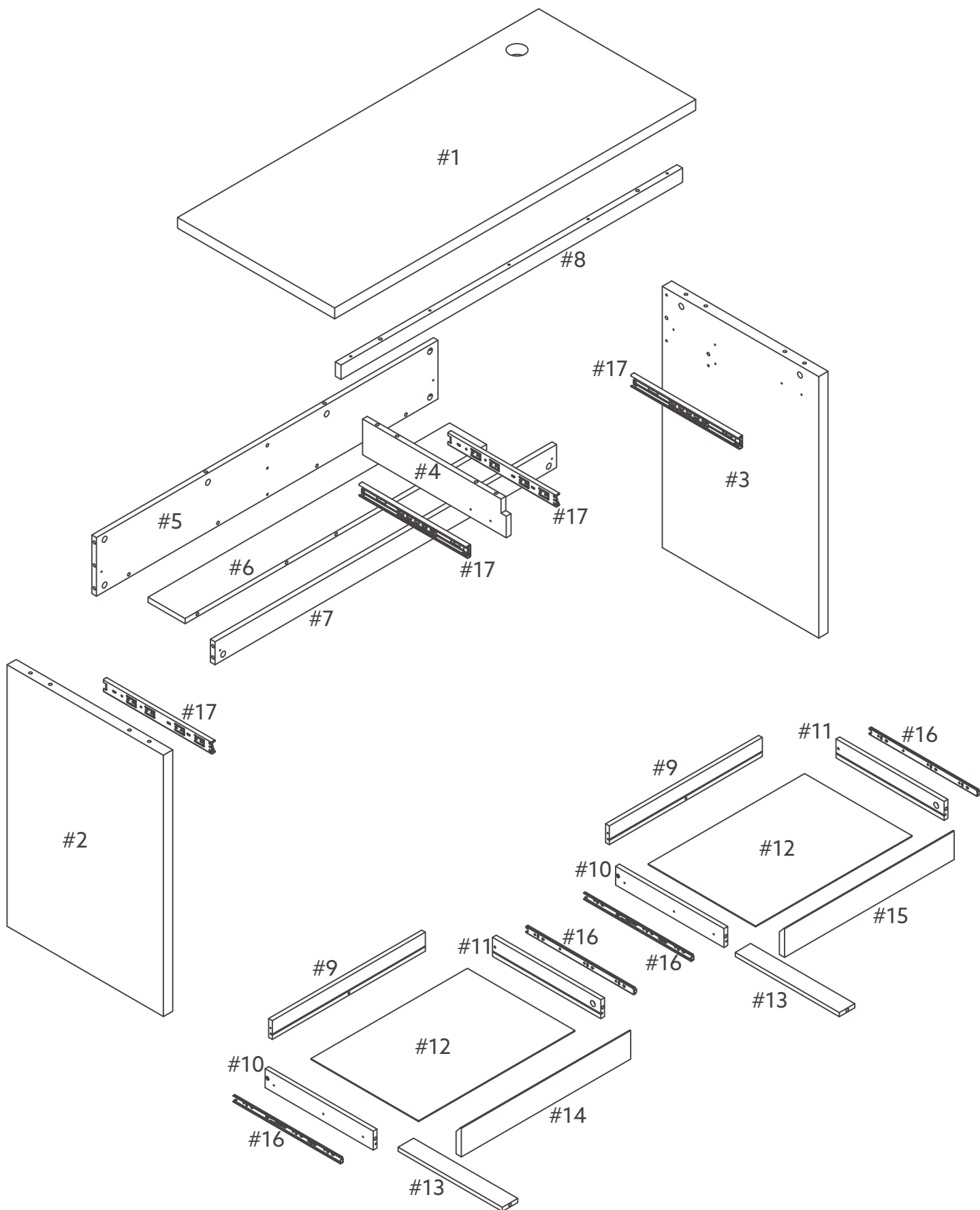

SPARE PARTS - NON AVAILABLE FOR REPLACEMENT

PIÈCES DE RECHANGE - NON DISPONIBLES POUR REMPLACEMENT

PIEZAS DE REPUESTO - NON DISPONIBLES PARA REMPLAZO

69338GRY-01-GOC	TOP PANEL / PANNEAU SUPÉRIEUR / PANEL SUPERIOR	01
-----------------	--	----

SPARE PARTS - AVAILABLE FOR REPLACEMENT

PIÈCES DE RECHANGE - DISPONIBLES POUR REMPLACEMENT

PIEZAS DE REPUESTO - DISPONIBLES PARA REMPLAZO

69338GRY-02-GOC	LEFT PANEL / PANNEAU GAUCHE / PANEL IZQUIERDO	01
69338GRY-03-GOC	RIGHT PANEL / PANNEAU DROIT / PANEL DERECHO	01
69338GRY-04-GOC	PARTITION/DIVISION/PANEL DIVISORIO	01
69338GRY-05-GOC	BACK PANEL / PANNEAU ARRIÈRE / PANEL POSTERIOR	01
69338GRY-06-GOC	BOTTOM PANEL / PANNEAU INFÉRIEUR / PANEL INFERIOR	01
69338GRY-07-GOC	RAIL / RAIL / RIEL	01
69338GRY-08-GOC	UPPER RAIL / RAIL SUPÉRIEUR / RIEL SUPERIOR	01
69338GRY-09-GOC	DRAWER - BACK / TIROIR - ARRIÈRE / CAJÓN - DETRÁS	02
69338GRY-10-GOC	DRAWER - LEFT / TIROIR - GAUCHE / CAJÓN - IZQUIERDA	02
69338GRY-11-GOC	DRAWER - RIGHT / TIROIR - DROITE / CAJÓN - DERECHA	02
69338GRY-12-GOC	DRAWER - BOTTOM / TIROIR - FOND / CAJÓN - FONDO	02
69338GRY-13-GOC	DRAWER BOTTOM SUPPORT / SUPPORT DU FOND DE TIROIR / SOPORTE DE FONDO DEL CAJÓN	02
69338GRY-14-GOC	LEFT DRAWER - FRONT/ GAUCHE TIROIR - AVANT / IZQUIERDA CAJÓN - ADELANTE	01
69338GRY-15-GOC	RIGHT DRAWER - FRONT/ DROITE TIROIR - AVANT / DERECHA CAJÓN - ADELANTE	01
69338GRY-16-GOC	GLIDE FOR DRAWER SIDE / COULISSE DE CÔTÉ - TIROIR / GUÍA LATERAL - CAJÓN	04
69338GRY-17-GOC	GLIDE FOR SIDE PANEL / COULISSE - PANNEAU LATÉRAL / GUÍA - PANEL LATERAL	04
69338GRY-00-GOC	HARDWARE PACK / PAQUET CONTENANT LA QUINCAILLERIE / JUEGO DE HERRAMIENTAS	04

HARDWARE LIST / LISTE DES PIÈCES / LISTAS DE PIEZAS

A		CAM BOLT / PÊNES BATTANTS / PERNO DE LEVA	23
B		CAM LOCK / SERRURES BATTEUESE / TRABA DE LEVA	23
C		SCREW / VIS / TORNILLO (Ø4X38MM)	06
D		WOOD DOWEL / GOUJONS DE BOIS / TARUGO DE MADERA (Ø8X30MM)	21
E		SCREW / VIS / TORNILLO (Ø3X12MM)	24
F		SCREW / VIS / TORNILLO (Ø5X12MM)	08
G		L-METAL / L MÉTAL / L METAL	04
H		GROMMET / ŒILLET / OJAL	01
J		SCREW / VIS / TORNILLO (Ø4X45MM)	05

NOTE: Find the label of "Hardware Enclosed" on one of the carton corner then follow the red ribbon to get the hardware bag.

REMARQUE: Repérez l'étiquette «Quincaillerie Incluse» sur le coin de la boîte, puis suivez le ruban rouge pour récupérer le sac contenant la quincaillerie.

NOTA: Busque la etiqueta "Ferretería Incluida" en una de las esquinas de la caja, luego siga la cinta roja para recuperar la bolsa que contiene la tornillería.

TOOLS REQUIRED / OUTILS REQUIS / HERRAMIENTAS REQUERIDAS

PHILLIPS SCREWDRIVER / TOURNEVIS PHILLIPS /
DESTORNILLADOR ESTÁNDAR



NOT SUPPLIED / NON FOURNI /
NO INCLUIDO

IMPORTANT:

1. Do not tighten bolts completely until all bolts are completely lined up and inserted into holes / nuts.
2. Do not over tighten screws and bolts to avoid stripping.
3. Please use hand tools to assemble this product. Do not use power tools.
4. For ease of assembly, two adults are recommended.

IMPORTANT:

1. Ne serrez pas complètement les boulons jusqu'à ce que tous les boulons soient complètement alignés et insérés dans les trous / écrous.
2. Ne pas trop serrer les vis et les boulons pour éviter d'endommager les filets.
3. Utilisez des outils à main pour assembler ce produit. N'utilisez pas d'outils électriques.
4. L'assemblage par deux adultes est recommandé.

IMPORTANTE:

1. No apriete completamente los pernos hasta que todos los tornillos estén alineados completamente y se inserten en los agujeros / tuercas.
2. No apriete demasiado los tornillos y los pernos para evitar dañar los filetes.
3. Utilice herramientas de mano para montar este producto. No utilice herramientas eléctricas.
4. Se recomienda el montaje por dos adultos.

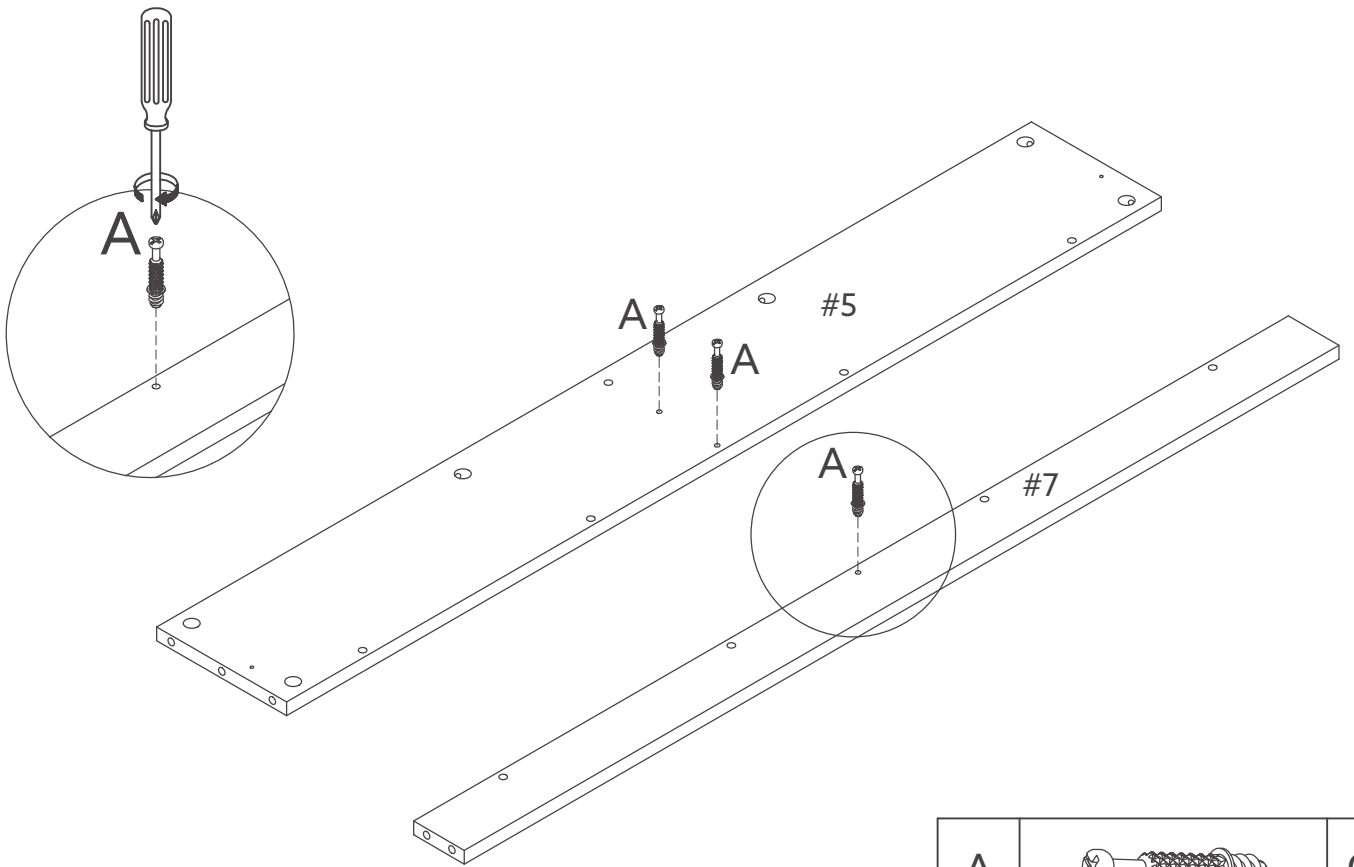

1.

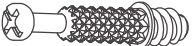

A		03
---	--	----

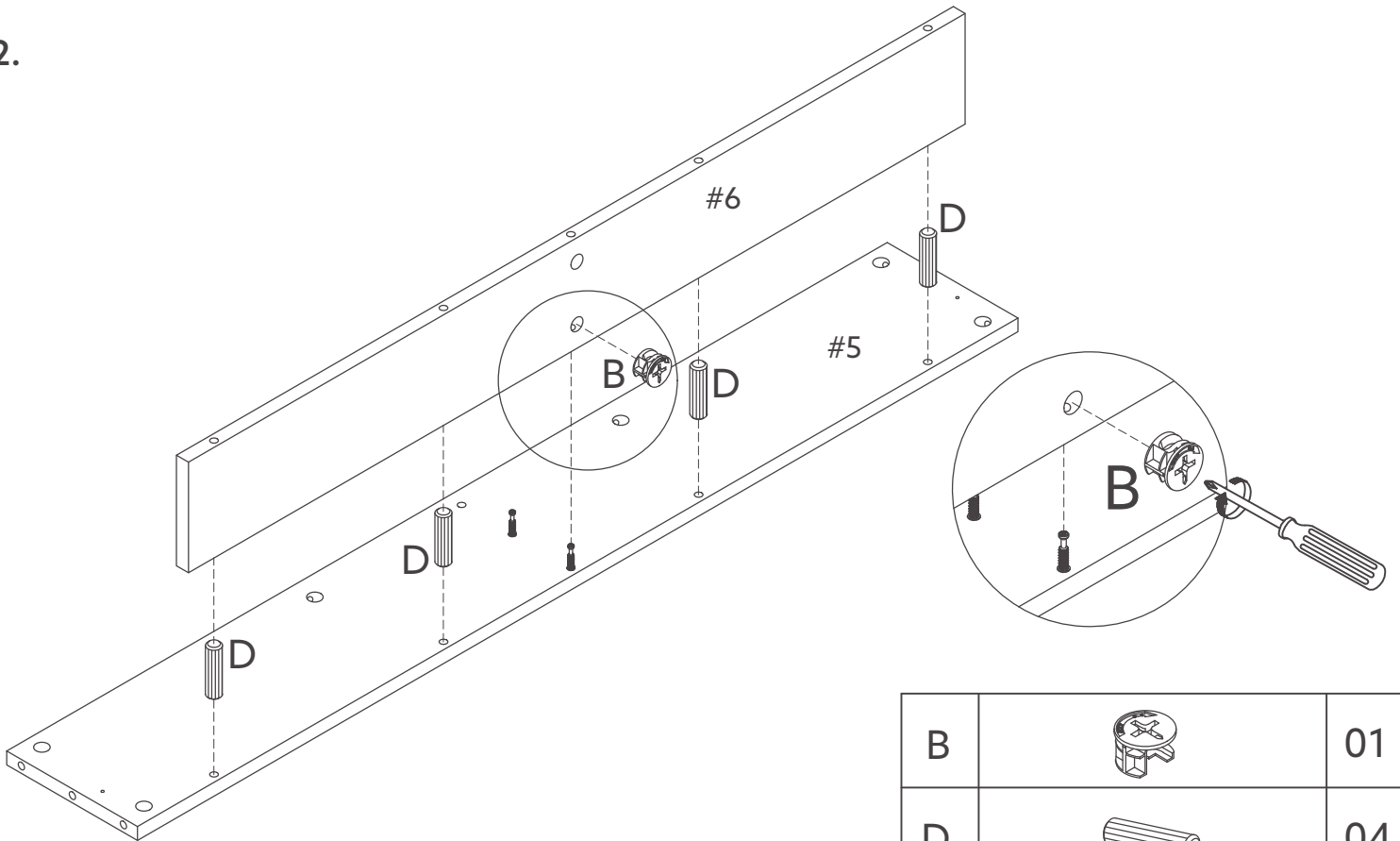
2.



B		01
D		04

3.

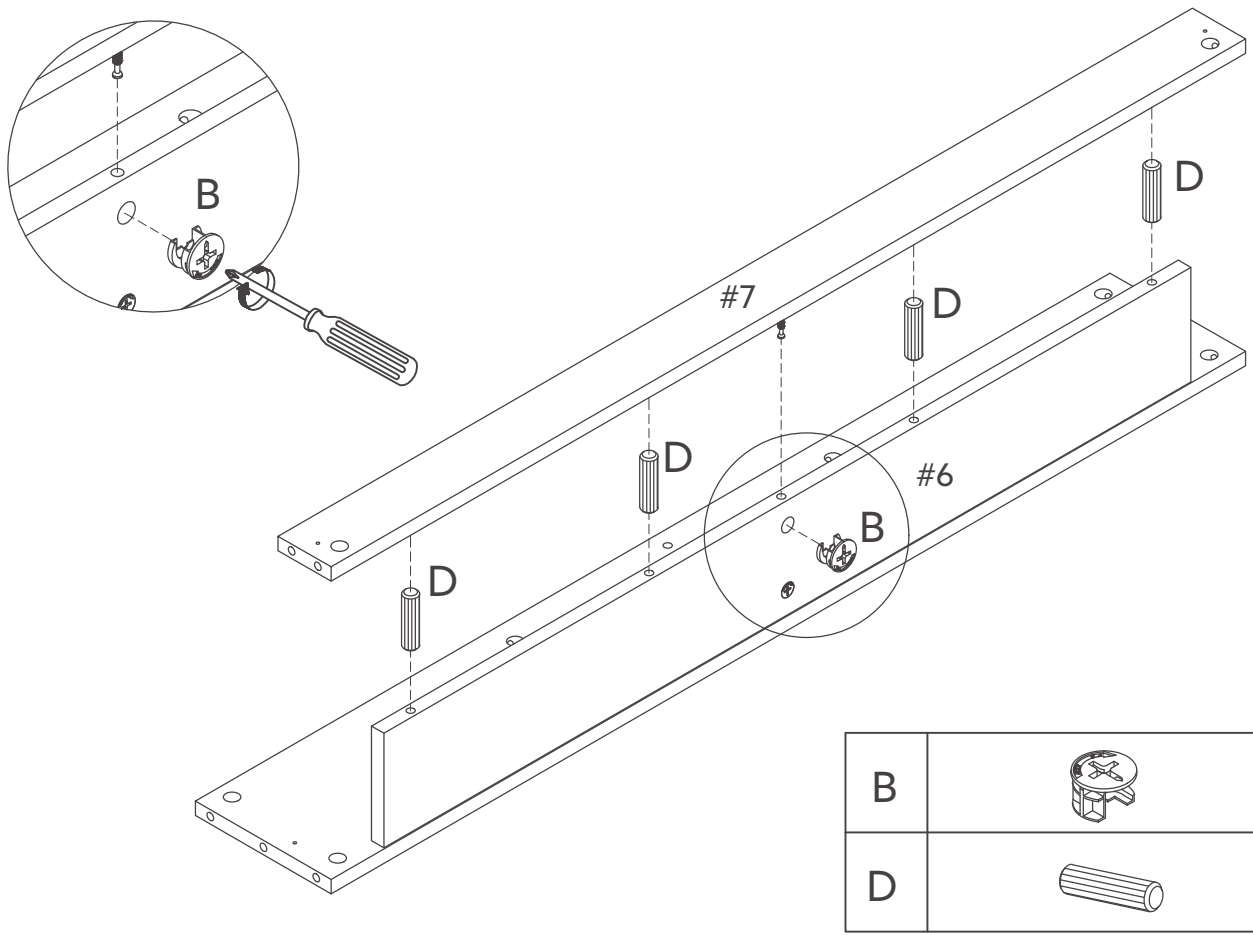

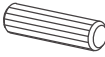
B		01
D		04

4.

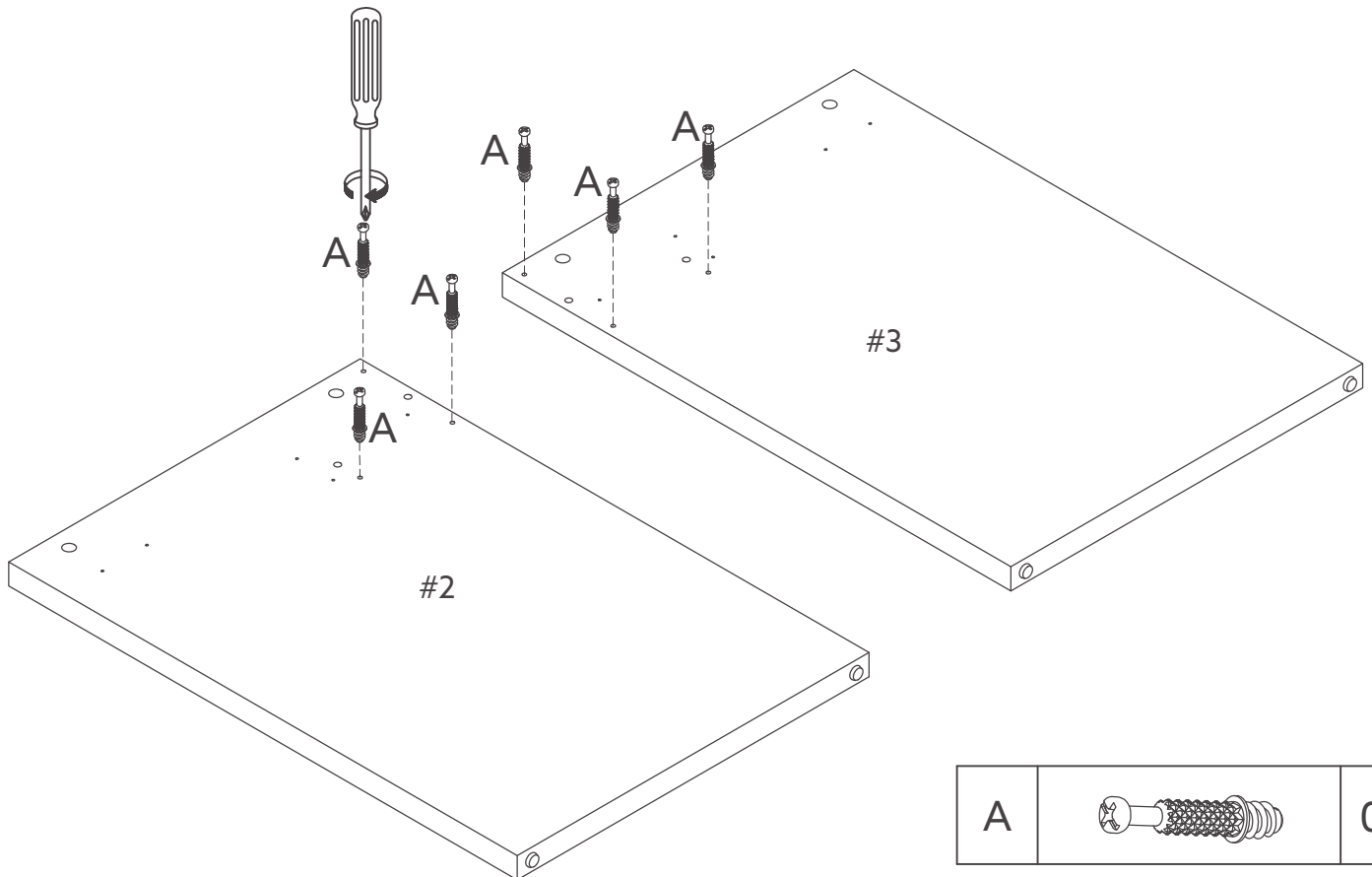

A		06
---	---	----

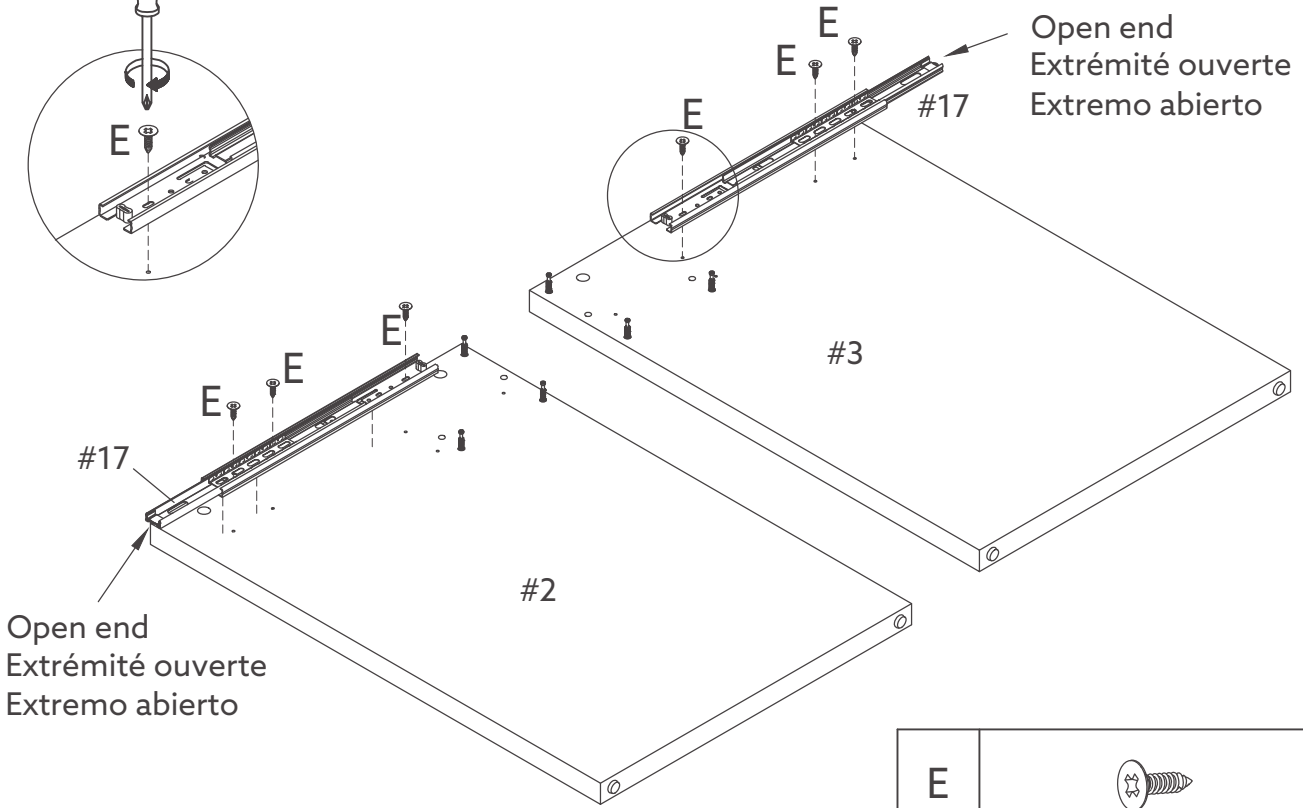
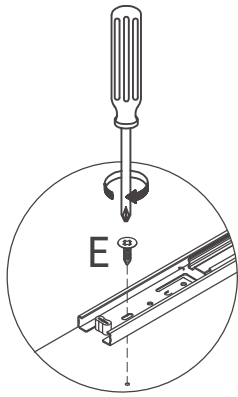

5.

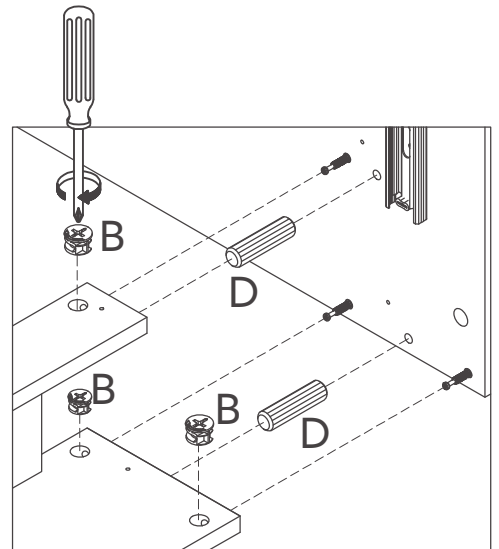
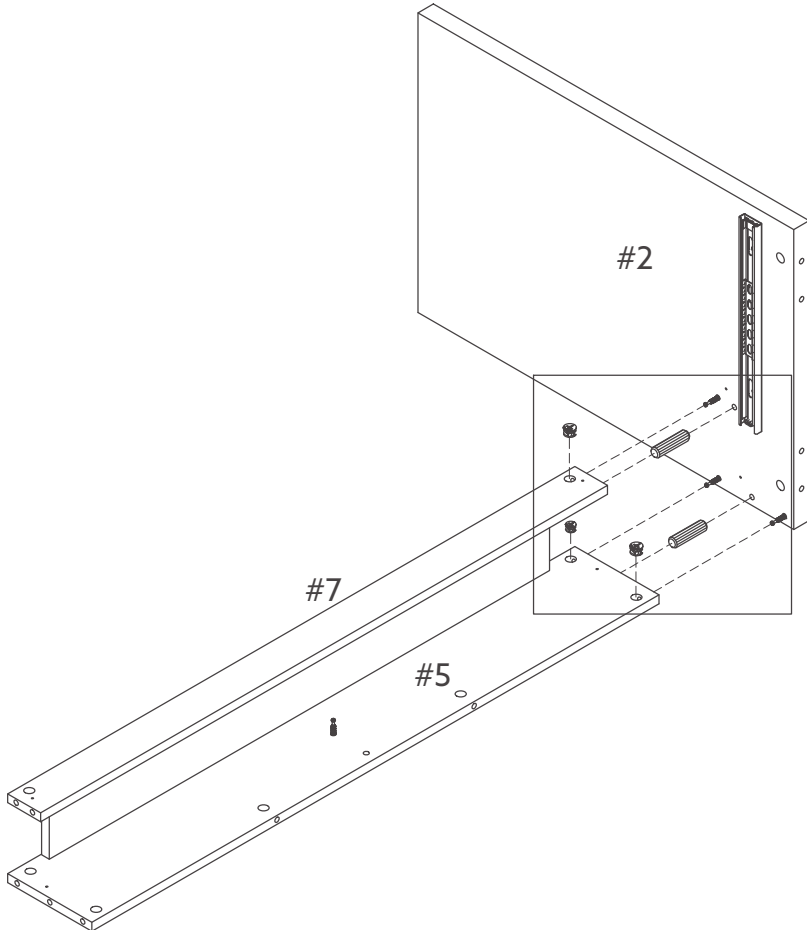

E		06
---	--	----

6.



B		03
D		02

7.

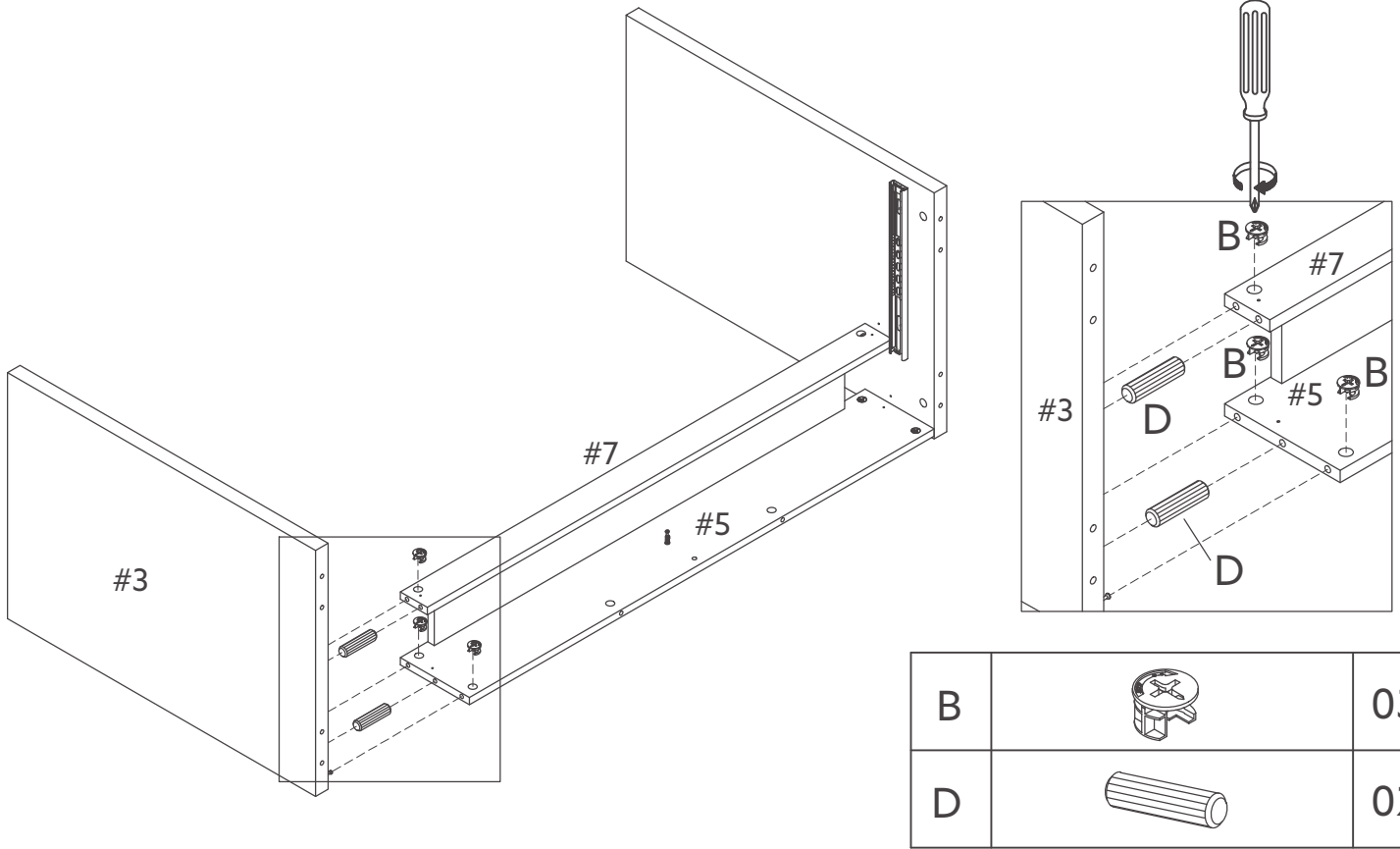

8.

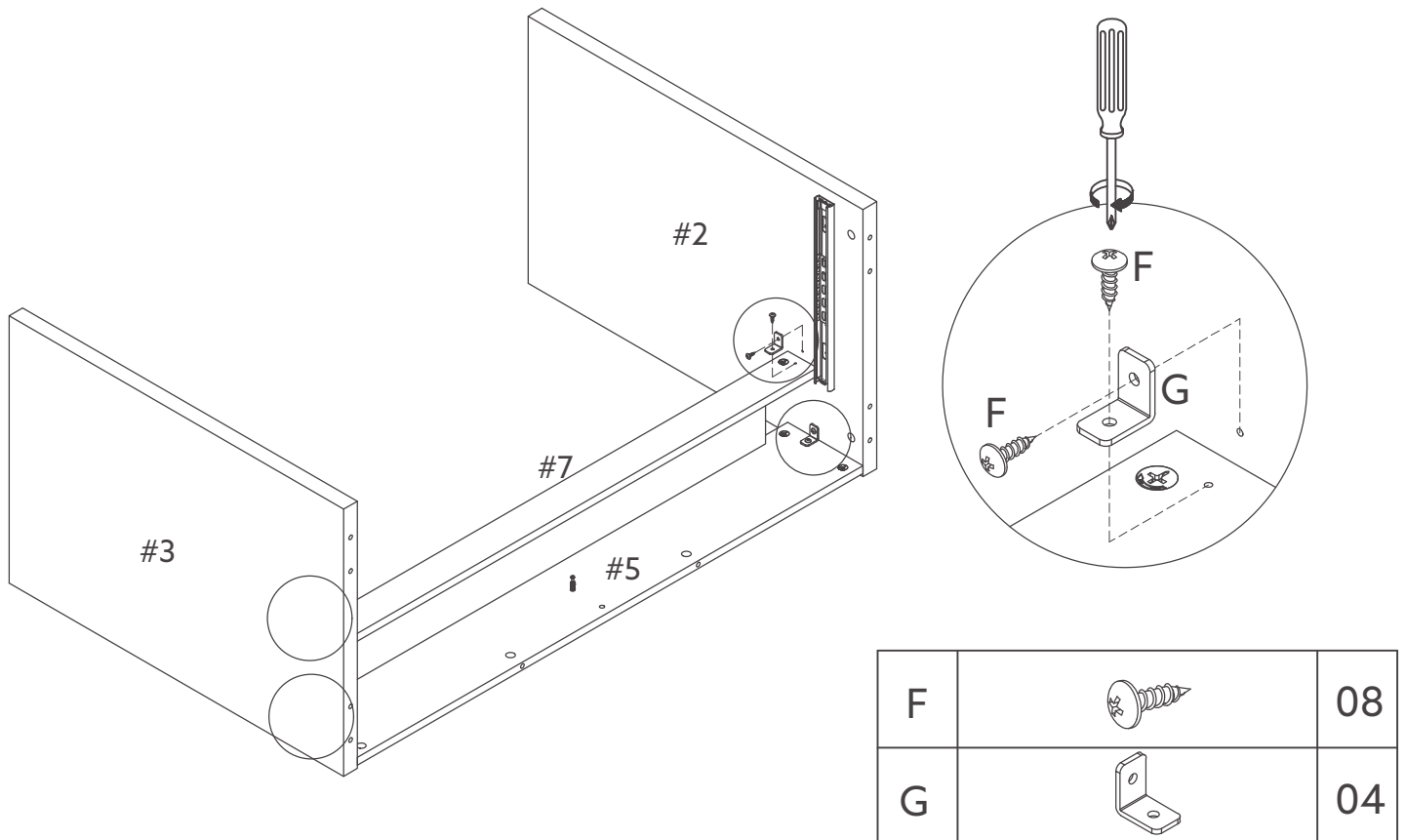

9.

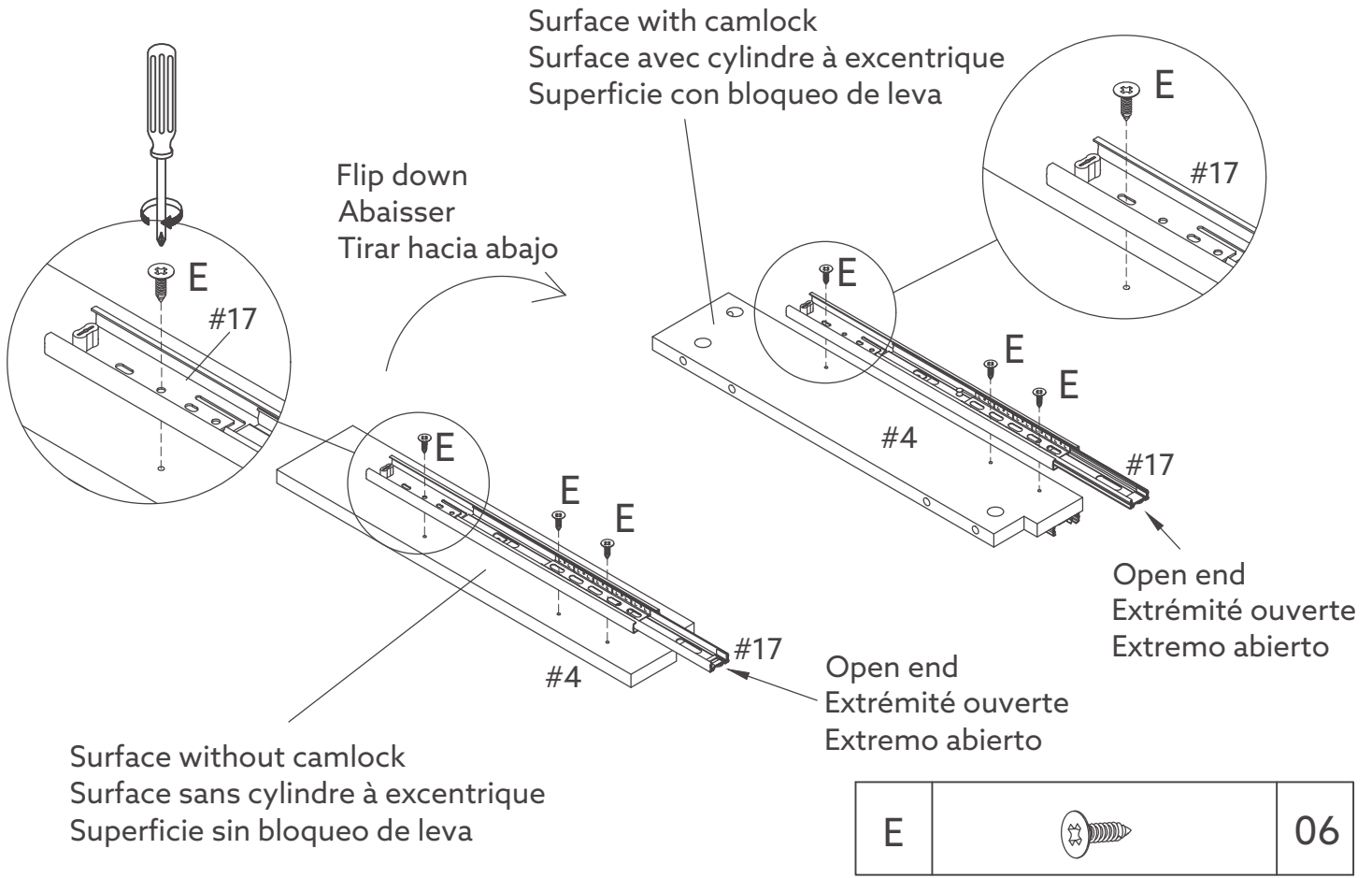

10.

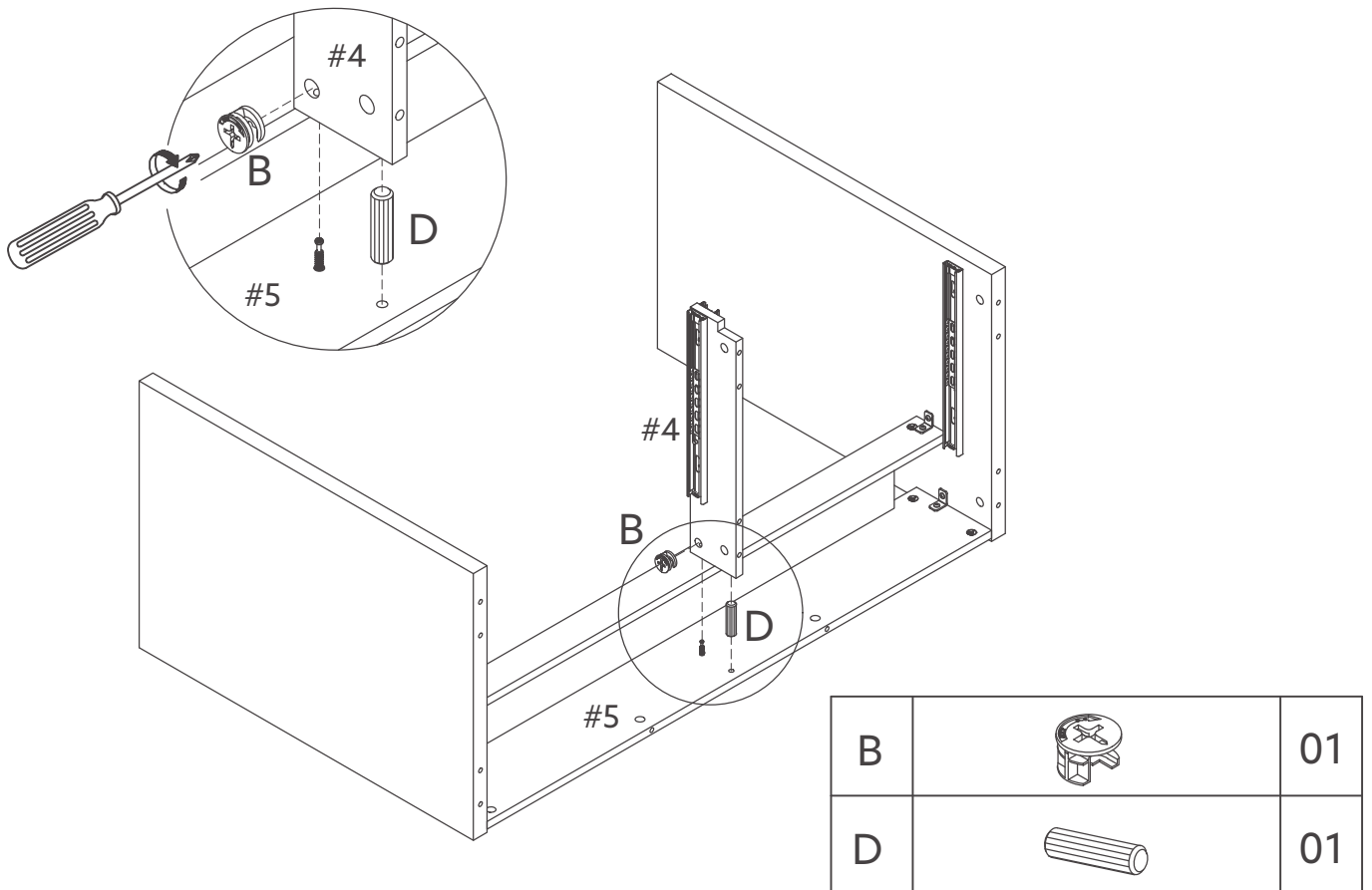

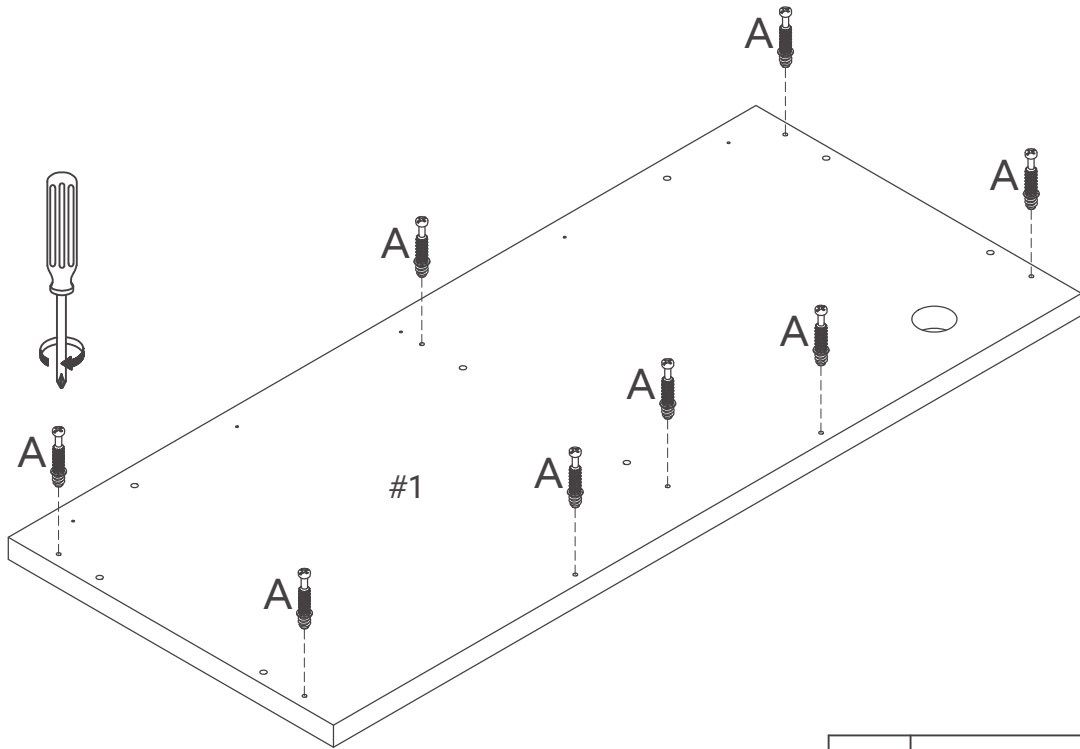

11.



A		08
---	--	----

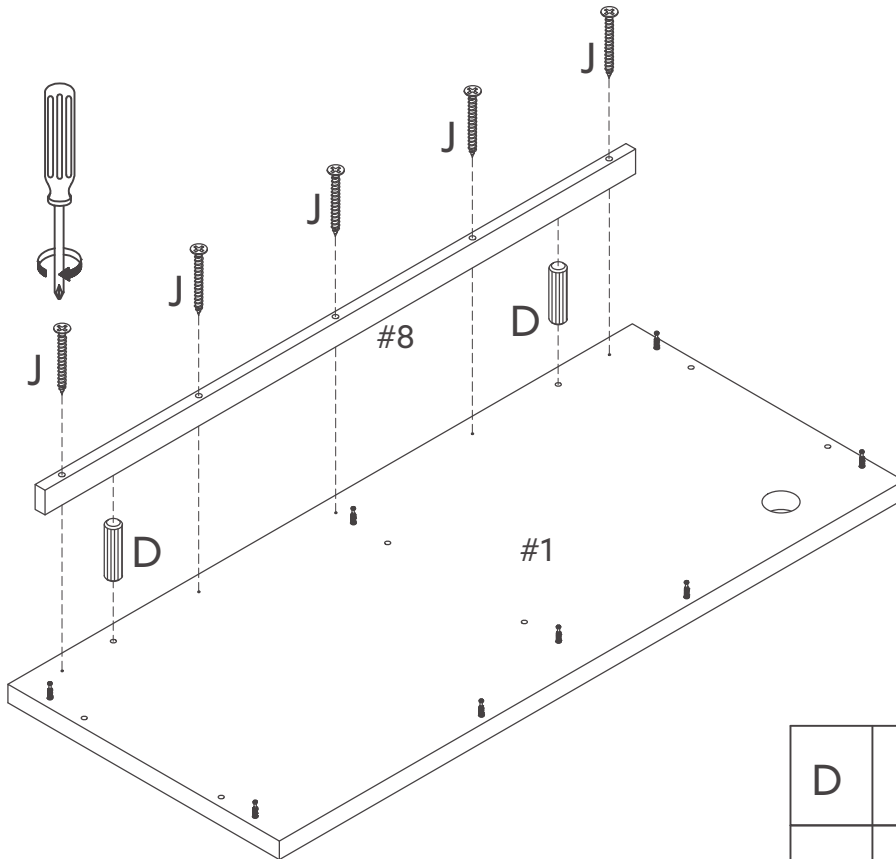

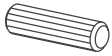
12.

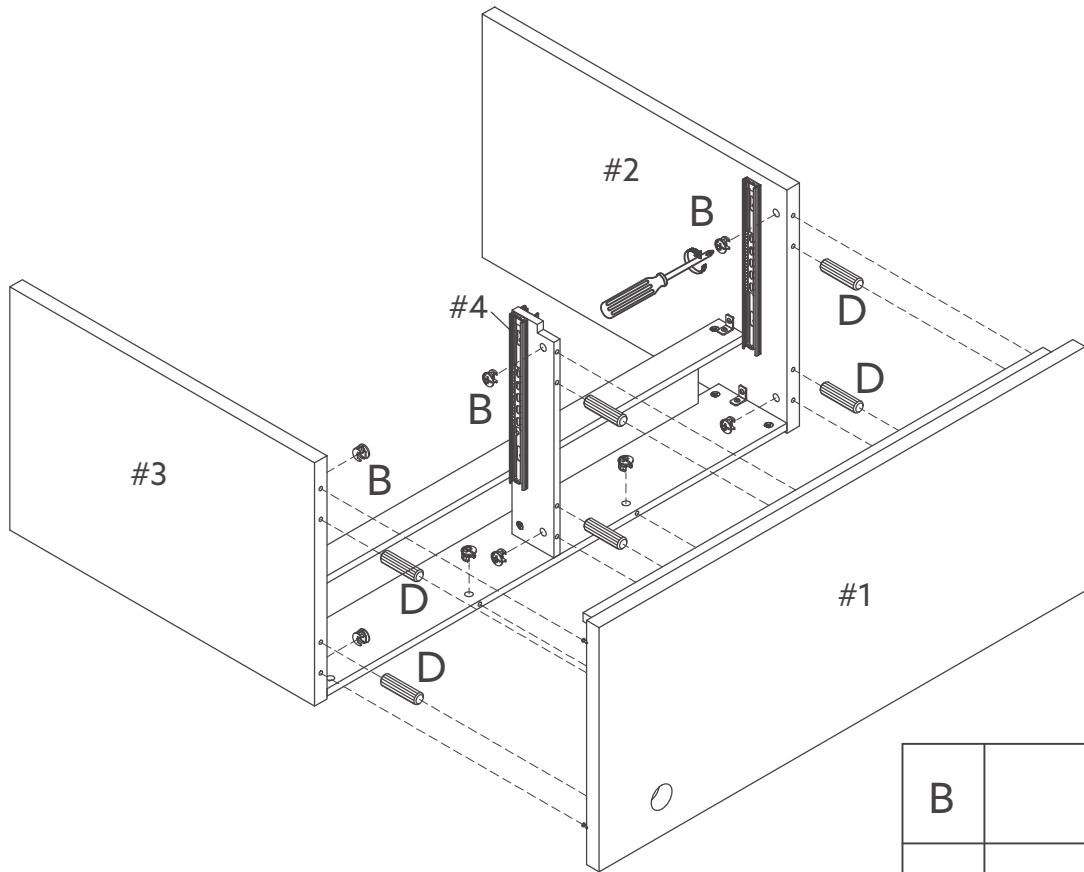

D		02
J		05

13.



B		08
D		06

14.

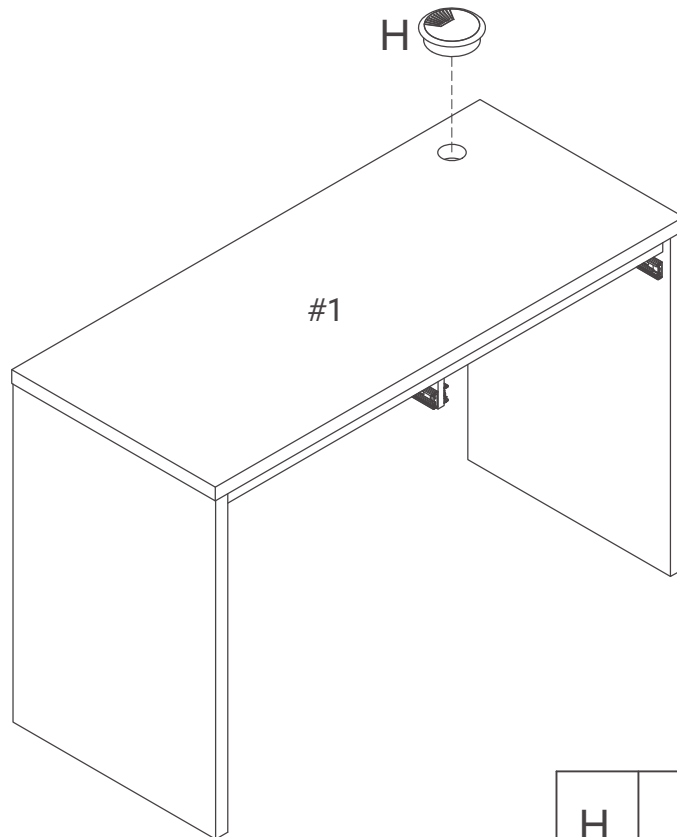

H		01
---	---	----

15.

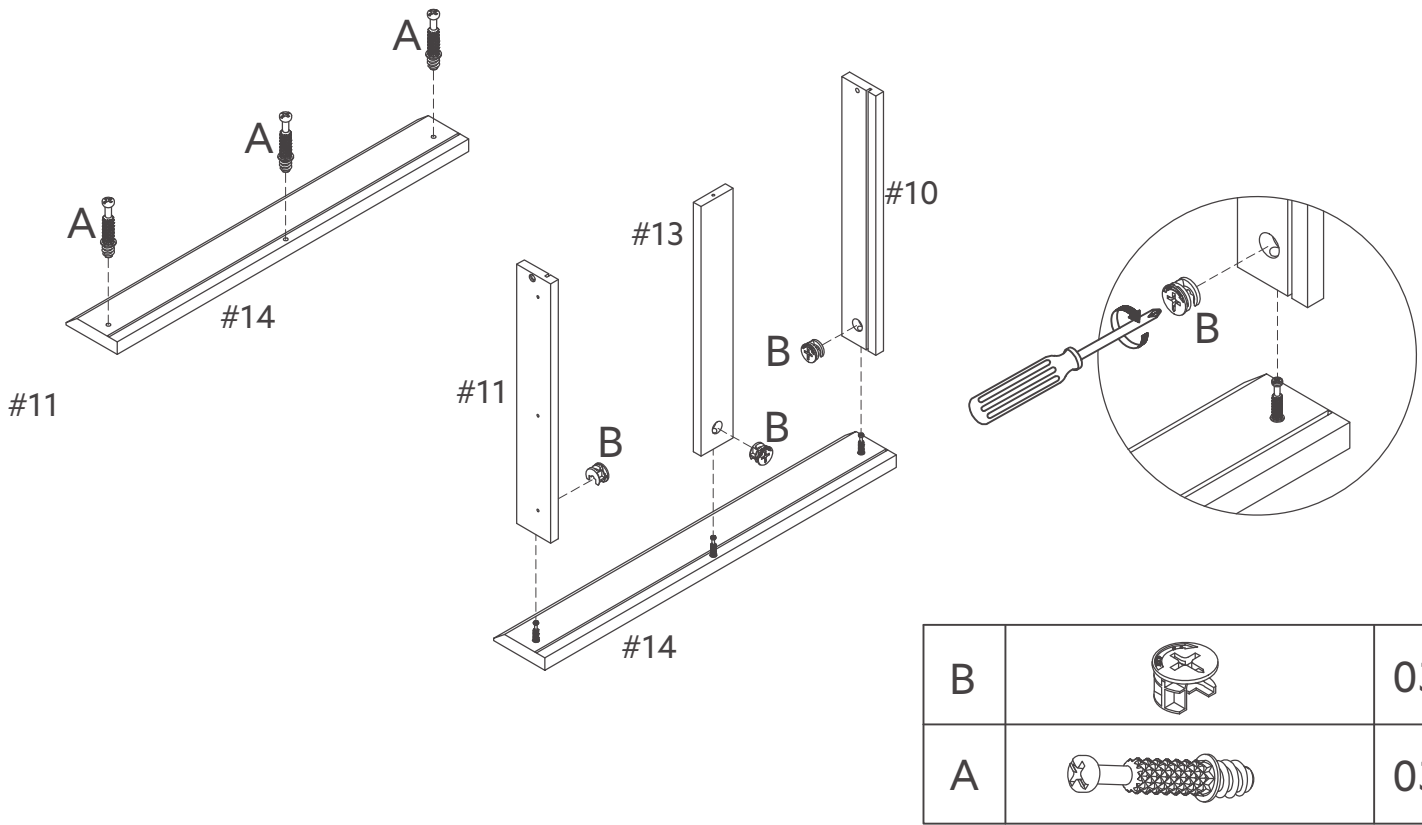

16.

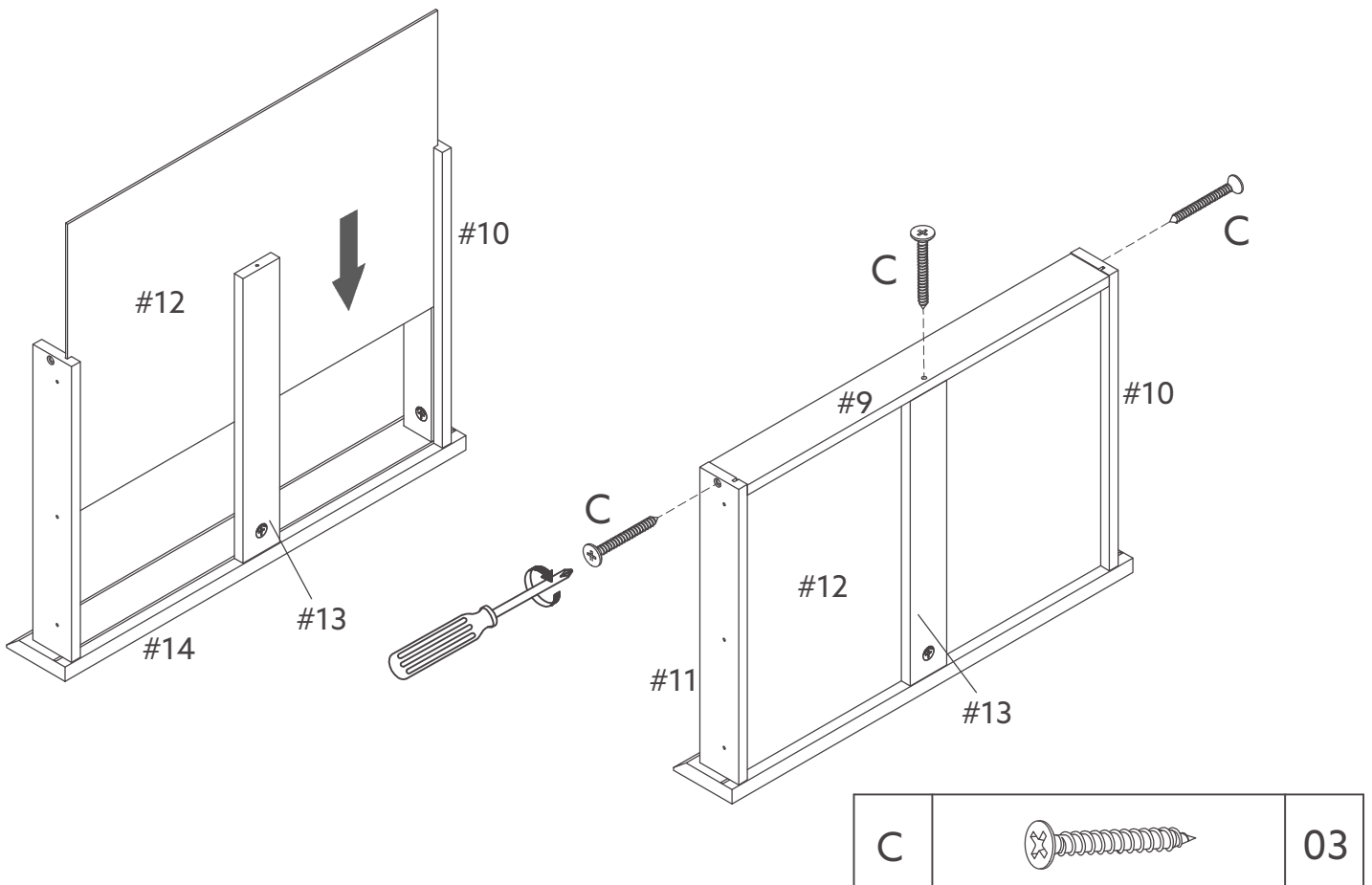

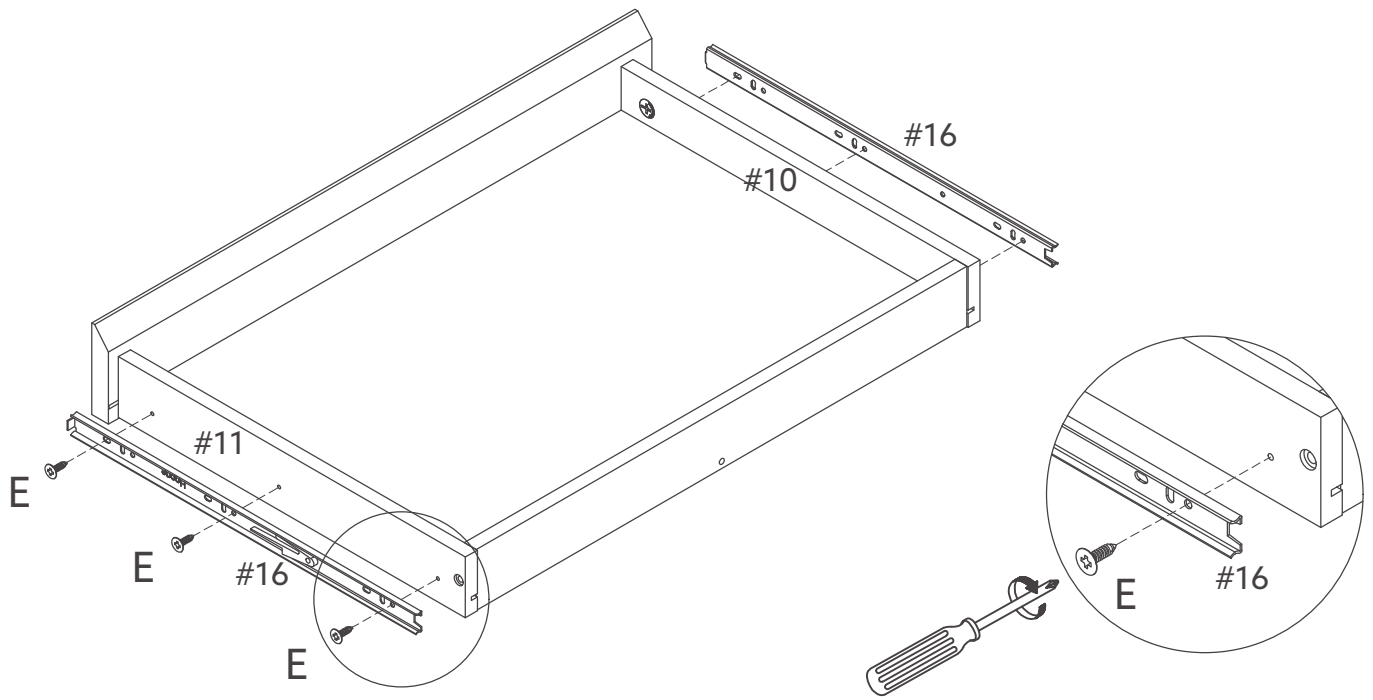

17.

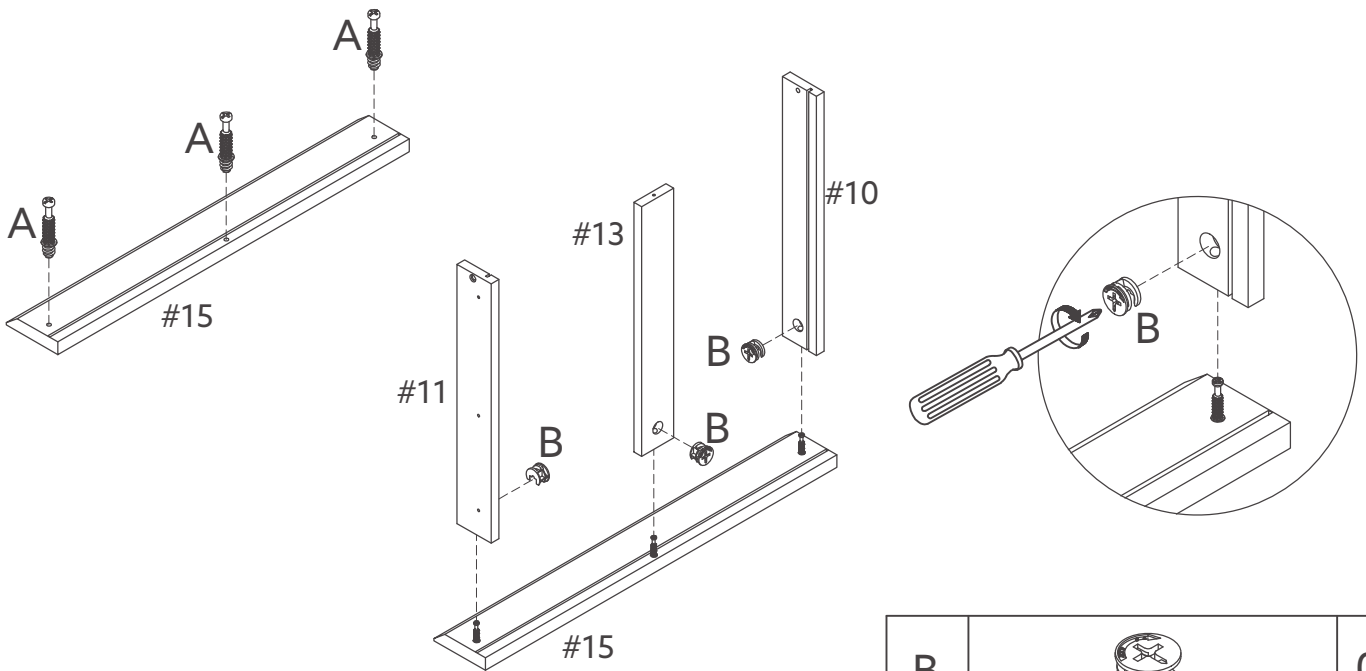

E		06
---	--	----

18.



B		03
A		03

19.

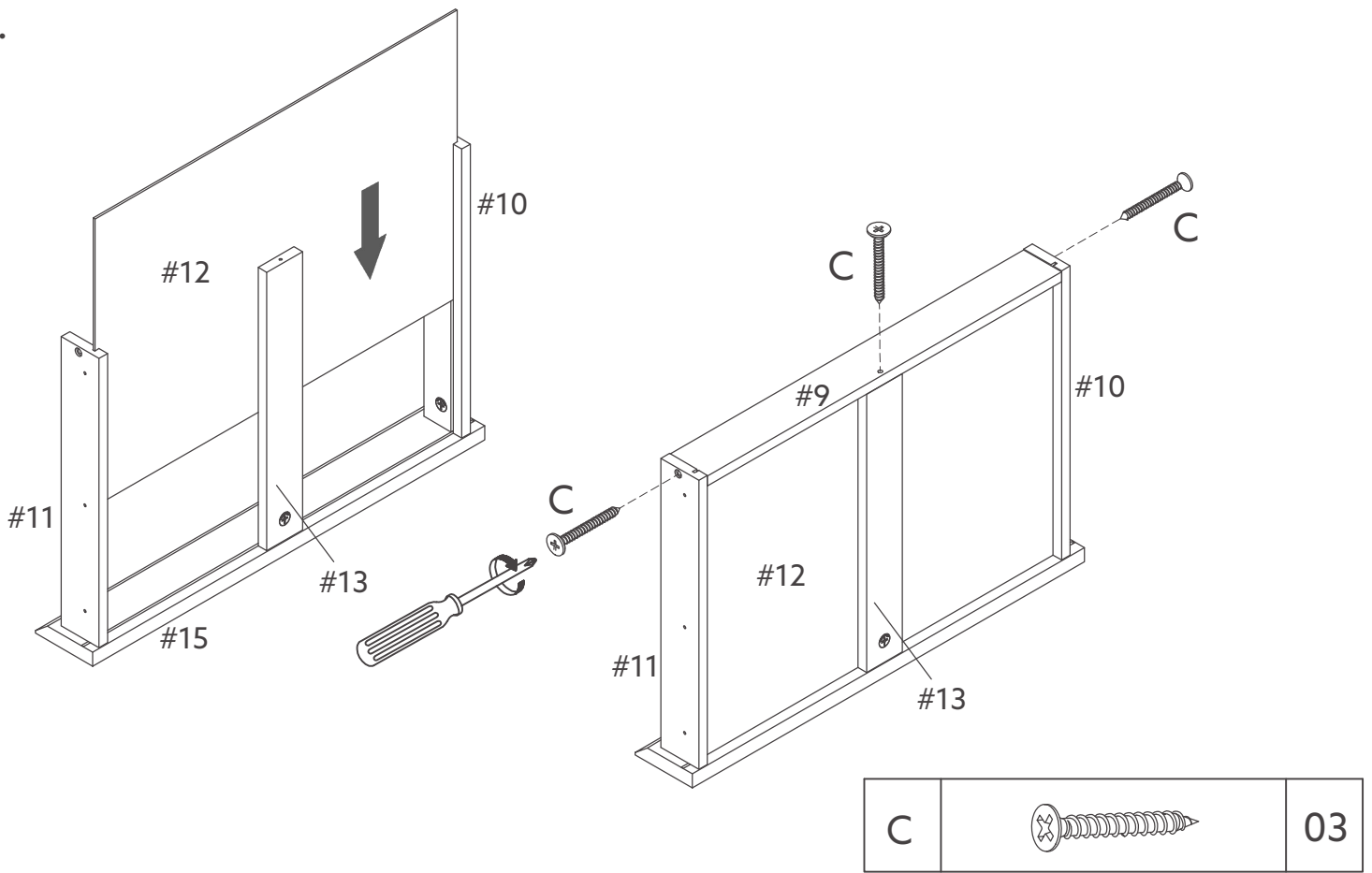

20.

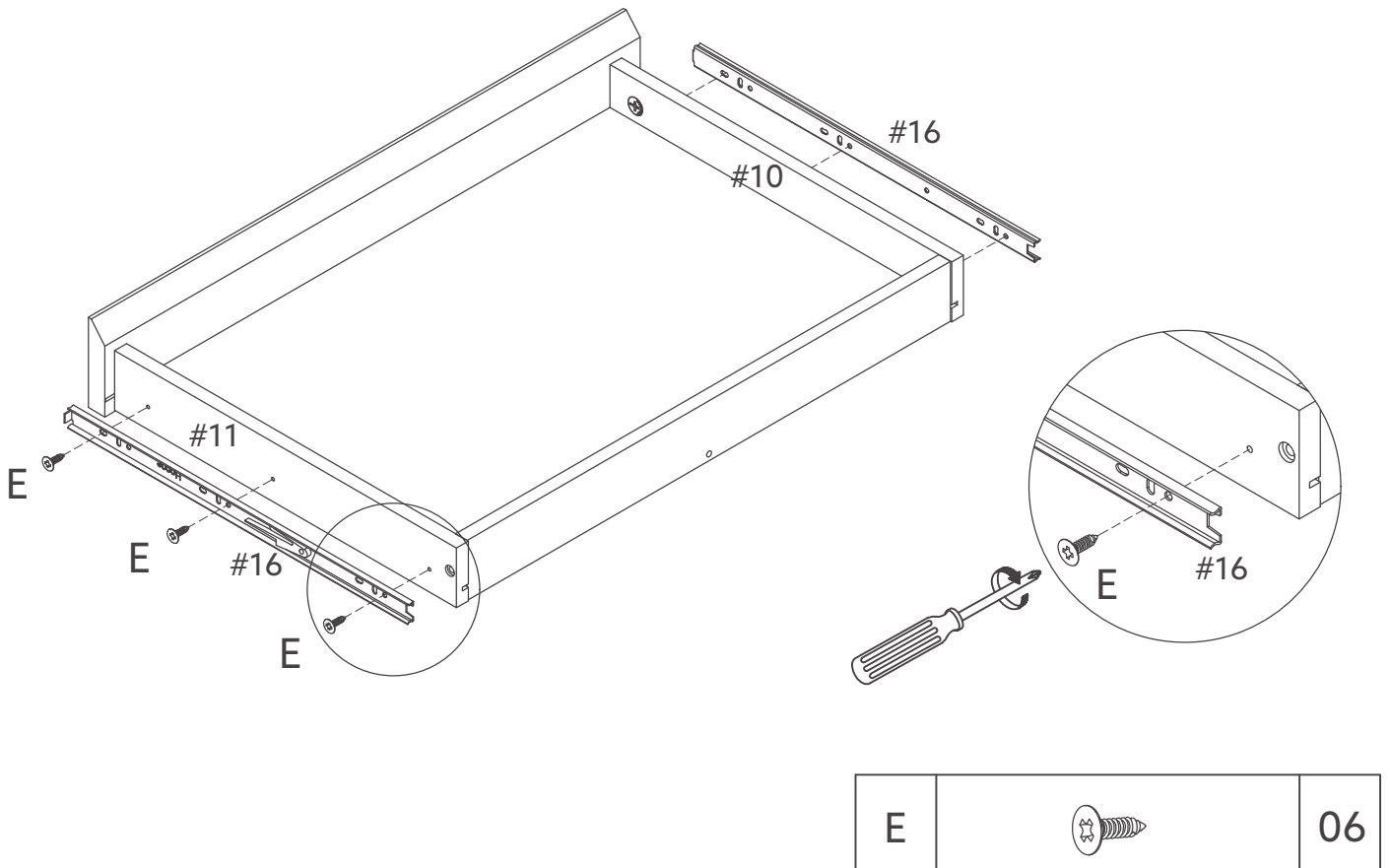

21.

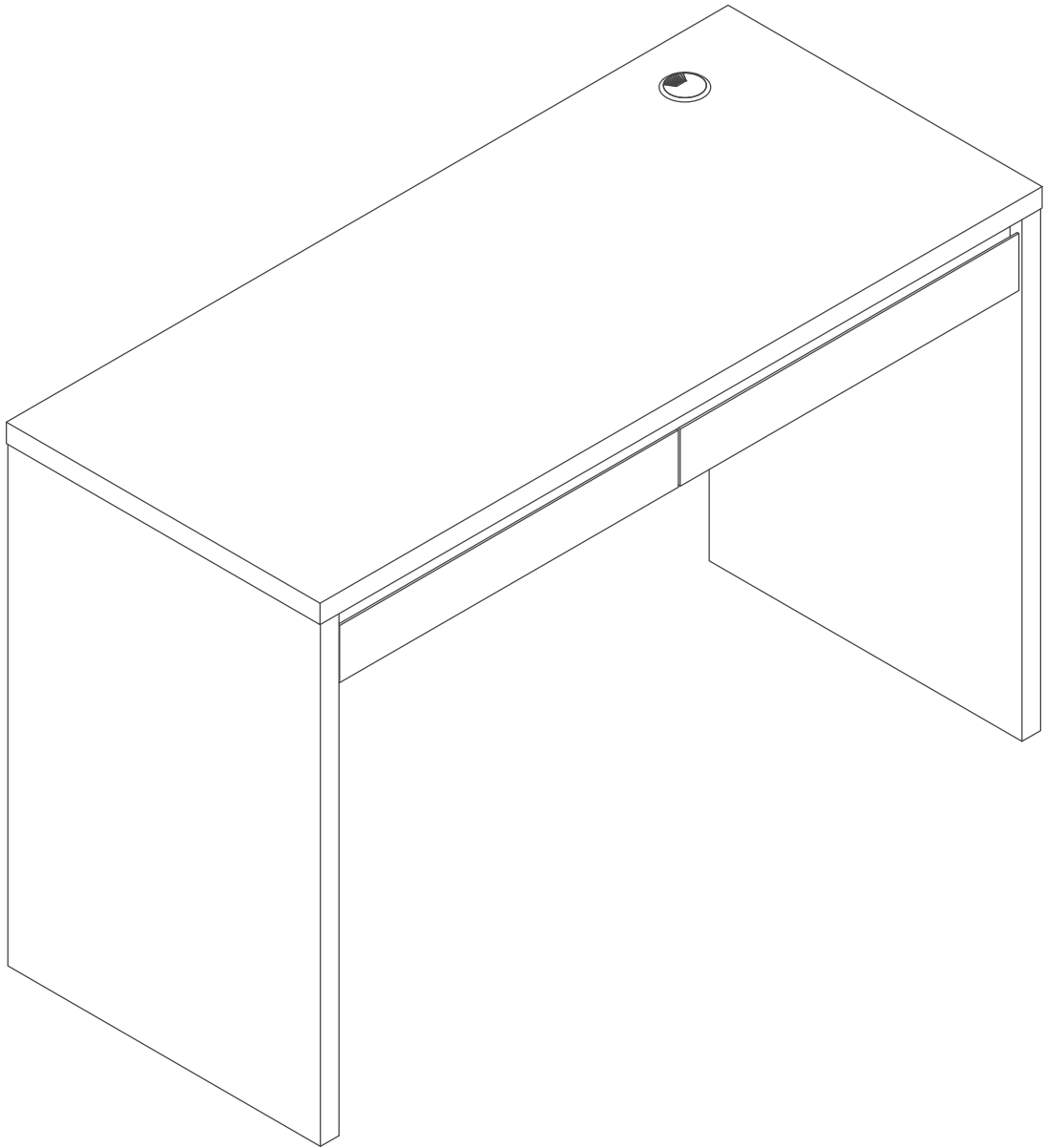

LIMITED 6 MONTHS WARRANTY

GARANTIE LIMITÉE DE 6 MOIS / GARANTÍA LIMITADA DE 6 MESES

WHAT IS COVERED

This product is covered under our manufacturer's 6 months limited warranty (Lion Home Décor Products). To ensure your complete satisfaction, this warrants to the original purchaser that the Lion supplied item is free from defects in material and workmanship, as of the date of purchase, and that it will, under normal use and proper care, remain so for six months after the date of purchase.

Replacement of missing or initially defective parts will be sent, at no charge, for a period of 30 days from the date of purchase with valid proof of purchase providing the parts are available in our warehouse and the item purchased is part of our current inventory.

QU'EST-CE QUI EST COUVERT

Ce produit est couvert sous une garantie limitée de 6 mois offerte par le fabricant. Afin d'assurer votre entière satisfaction, cela garantit à l'acheteur original que le produit fourni est exempt de défauts de matériaux et de fabrication à compter de la date d'achat.

Le remplacement de pièces manquantes ou défectueuses dès le départ sera envoyé, sans frais, pour une période de 30 jours suivant la date d'achat avec une preuve d'achat valide pourvu que les pièces soient disponibles dans notre entrepôt et que l'article acheté fait partie de notre inventaire actuel.

QUÉ ESTÁ CUBIERTO

Este producto está cubierto por la garantía limitada de 6 meses de nuestro fabricante. Para asegurar su total satisfacción, ésta garantiza al comprador original que el artículo proporcionado se encuentra libre de defectos materiales y de fabricación, a partir de la fecha de compra, y que permanecerá en tal estado, sometido a un uso normal y cuidados adecuados, durante los seis meses posteriores a la fecha de la compra.

Las partes faltantes o que presenten defectos al inicio de ese período de tiempo serán enviadas sin cargo, durante un lapso de 30 días a partir de la fecha de compra, mediante la presentación de un comprobante de compra válido, siempre que las partes estén disponibles en nuestro almacén y el artículo adquirido sea parte de nuestro inventario actual.

WHAT IS NOT COVERED

It remains the customer's responsibility for freight and packaging charges to and from the customer service center. Labor and material charges to remove or replace parts under this warranty are not covered.

This warranty does not cover: Furniture used for commercial purposes, failures caused by improper installation assembly or by improper care, unreasonable or abusive use, freeze damage, acts of God, rust, purchased parts or return freight and packaging charges. Proof of purchase (dated register receipt) is required for warranty claims.

QU'EST-CE QUI N'EST PAS COUVERT

Il y va de la responsabilité du client de couvrir les frais de transport et d'emballage vers et à partir du centre de service après-vente. Les frais de la main-d'œuvre et des matériaux pour retirer les pièces ou les remplacer sous cette garantie ne sont pas couverts.

Cette garantie ne couvre pas : les meubles utilisés à des fins commerciales, les défaillances causées par un mauvais assemblage ou entretien (sans dépasser les limites de poids), l'utilisation déraisonnable ou abusive, les dommages causés par le gel, la rouille, les frais de transport et d'emballage pour des pièces achetées ou retournées. Une preuve d'achat (reçu de caisse date) est requise pour les réclamations sous garantie.

QUÉ NO ESTÁ CUBIERTO

El cliente asumirá los costos de flete y empaque hacia y desde el centro de servicio de cliente. Los cargos de material y mano de obra para extraer o reemplazar partes en el marco de la garantía no están cubiertos.

Esta garantía no cubre: muebles utilizados con fines comerciales, fallas causadas por montaje de instalación inadecuados o uso indebido (se recomienda no exceder los límites de peso), uso no razonable o abusivo, daños por congelación, oxidación, partes compradas, flete de devolución y cargos de empaque. Se exigirá el comprobante de compra (la factura de registro con fecha) para hacer valer la garantía.

HOW TO OBTAIN SERVICE

For further information, please contact our customer service department, c/o Lion Home Décor Products, Inc., between 9:00 AM and 5:00 PM EST, Monday through Friday:

Email address: consumersupport@lion.com

COMMENT FAIRE POUR OBTENIR DU SERVICE

Pour de plus amples renseignements, veuillez communiquer avec notre département du service à la clientèle, entre 9 h et 17 h HNE, du lundi au vendredi.

Adresse de courriel : consumersupport@lion.com

CÓMO OBTENER SERVICIO

Si desea más información, póngase en contacto con nuestro departamento de servicio al cliente, de lunes a viernes entre las 9:00 a.m. y las 5:00 p.m., hora estándar de los Estados Unidos.

Correo electrónico: consumersupport@lion.com

MADE IN VIETNAM
FABRIQUE AU VIETNAM
HECHO EN VIETNAM

GOC-20437

INSTAGRAM: @LIONHOMEDÉCOR
TWITTER: LION HOME DÉCOR

THANK YOU FOR YOUR PURCHASE!

We LOVE seeing our products in your home. Take a photo and share it with us using the hashtag #LionLiving for a chance to be featured on our Instagram!

FACEBOOK: LION HOME DÉCOR
PINTEREST: LION HOME DÉCOR





DESK
BUREAU
ESCRITORIO