

USAGE INSTRUCTION

TRIENA 30" PAD BACK FOLDING BAR STOOL

01832ESP-01-AS-U

OPENING

Pull up the front of cushion and press down the back of cushion.

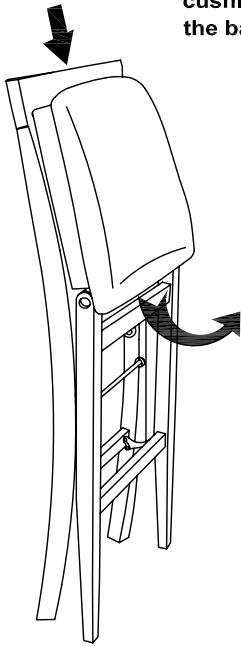

Direct press down the metal brace and back of cushion until the end for move the front leg out.

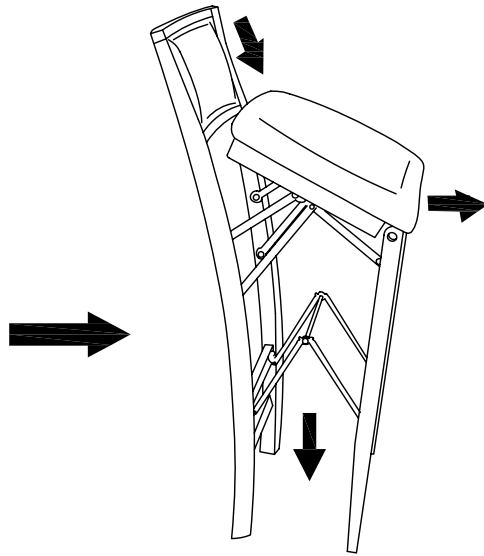

Completed

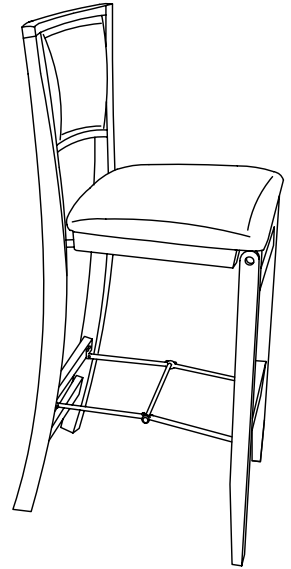

FOLDING

Pull up the metal brace and back of the cushion, then push the front of cushion.

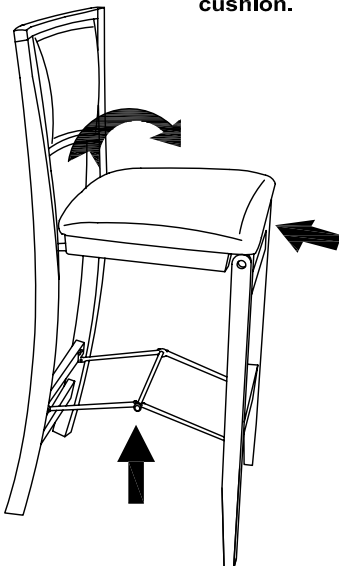

Direct push the front of cushion until the end and the cushion back will rise up.

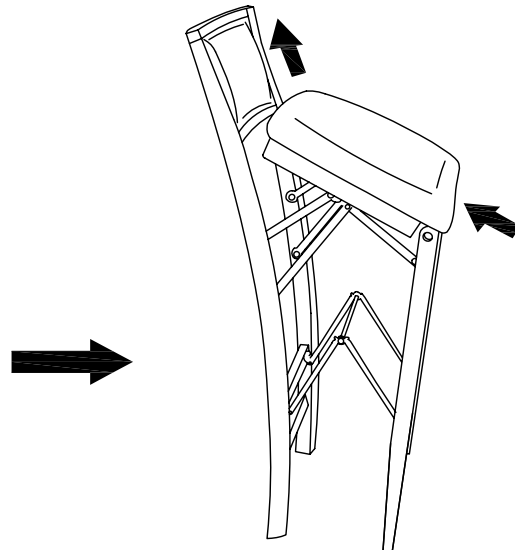

Completed

