

# 58901CH

## PART LIST

CODE	QTY
A	1
B	1
C	1
D	1
E	1
F	1
G	1
H	1
I	1
J	1
K	2
L	1
M	4
N	5
O	5
P	5
Q	5
R	1
S	1
T	1
U	5

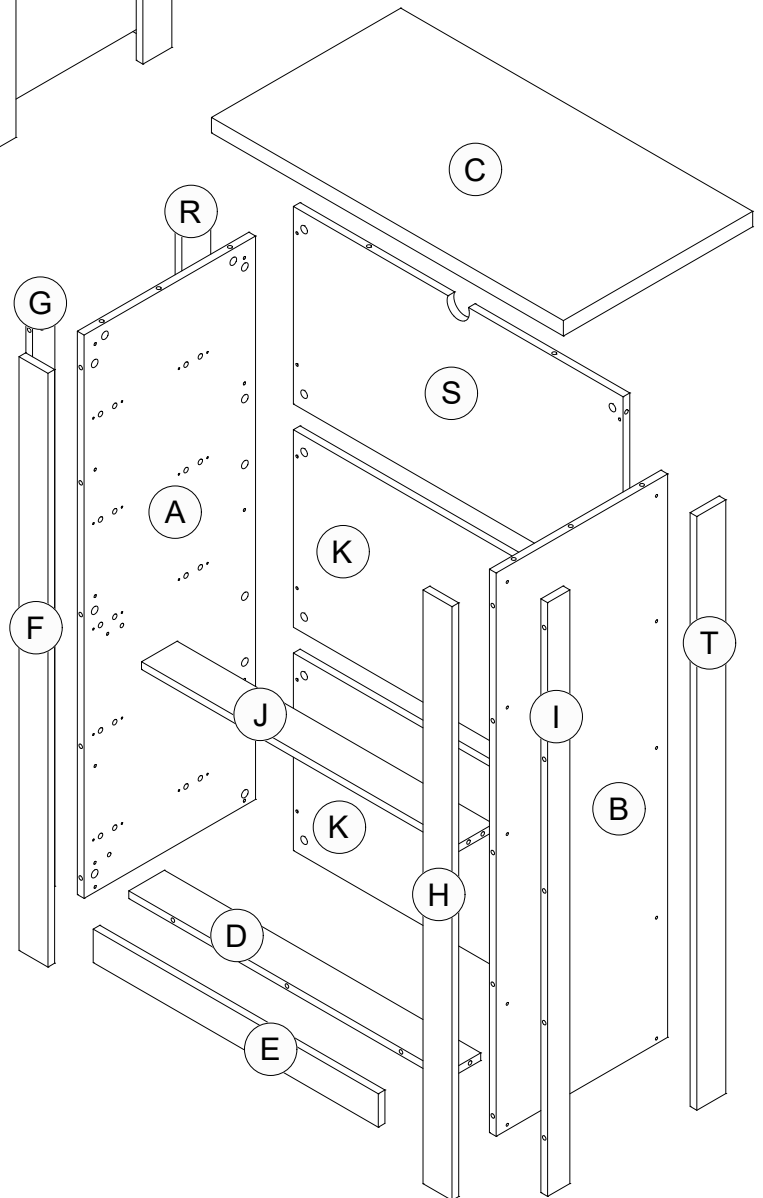
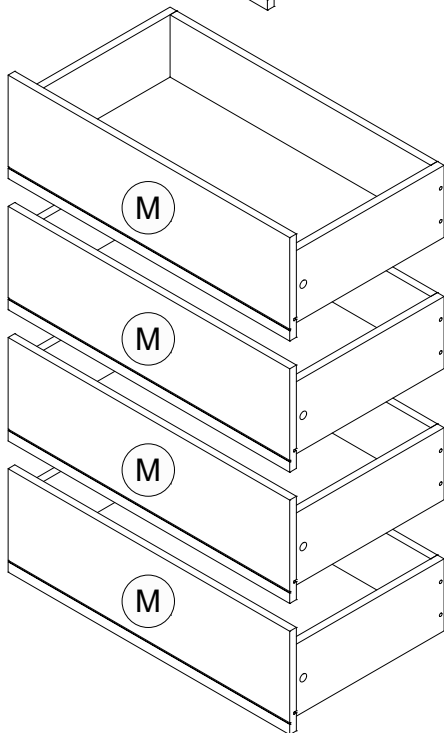
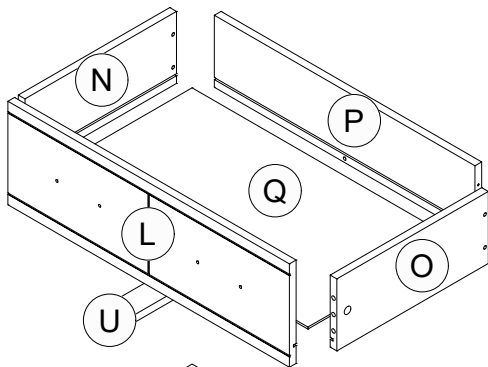
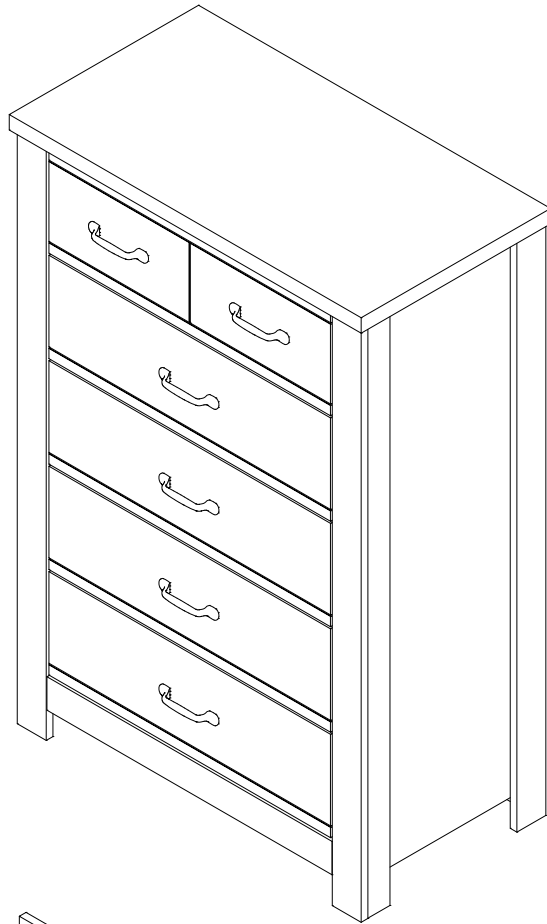

## NOTES ON ASSEMBLY / NOTES POUR L'ASSEMBLAGE / NOTAS SOBRE EL ENSAMBLE

- To ensure ease of assembly read all instructions before assembly and follow step by step illustrations.
- Keep instructions for future use.
- Adult assembly required. ⚠
- Due to the presence of small parts during assembly, keep out of reach of children until assembly is complete.

- Pour assurer l'assemblage facile veuillez lire toutes les instructions avant l'assemblage et veuillez suivre les illustrations pour chaque étapes.
- Veuillez garder ces instructions pour l'usage ulterieur.
- Assemblage requis pas un adulte. ⚠
- Due a la presence de petite pieces durant l'assemblage, veuillez garder hors de porter des enfants jusqu'a ce que l'assemblage soit completer.

- Para garantizar la facilidad de ensamble lea las instrucciones antes de iniciar y siga paso a paso las ilustraciones.
- Guarde las instrucciones para futuras referencias.
- El ensamble requiere de un adulto. ⚠
- Debido a que hay piezas pequeñas, mantenga fuera del alcance a los niños durante el ensamble, hasta que haya terminado.

## MAINTENANCE TIPS / CONSEILS D'ENTRETIEN / CONSEJOS DE MANUTENIMIENTO

- Never let liquids or damp cloths sit on this furniture.
- Never use chemical cleaning products. They can damage the finish. For cleaning, use only a slightly damp cloth and wipe dry.
- To avoid dulling of the finish, do not place furniture in direct sunlight.
- Do not put plastic or rubber rings under appliances. Use cloth of felt protectors.
- To clean, use a soft or slightly damp cloth, then wipe with a clean, dry cloth.

- Ne jamais laisser de liquide ou linge humide sur le meuble.
- Ne jamais utiliser de nettoyeurs à base de produits chimiques, cela va endommager le fini. Utiliser seulement un linge légèrement humide.
- Ne pas placer le meuble directement au soleil pour prévenir le ternissement.
- Évitez de déposer des appareils avec des rondelles de plastique ou de caoutchouc. Utilisez un protecteur en tissu ou en feutre.
- Pour nettoyer, utilisez un linge doux ou légèrement humecté. Essuyez par la suite avec un linge propre et sec.

- Nunca deje un líquido o un trapo húmedo sobre el mueble.
- Nunca utilice limpiadores a base de químicos, estos dañaran le acabado. Use sólo un paño húmedo.
- No esponga el mueble directamente al sol para prevenir empañamiento.
- Evite apoyar aparatos con redondeles de plástico o de goma. Utilizar un protector de tela o de fieltro.
- Para limpiar, utilice un trapo suave o ligeramente humedecido. Seque luego con un trapo limpio y seco.

# WARNING AVERTISSEMENT / ADVERTENCIA

Serious or fatal crushing injuries can occur from furniture tip-over. To help prevent tip-over:

- It is important to place the safety bracket included.
- Place heaviest items in the lowest storage space.
- Never allow children to climb or hang on drawers, doors, or shelves.
- Never open more than one drawer at a time.
- If a heavy object is placed on top or inside the furniture, consider this risk.

Use of tip-over restraints reduce, but does not eliminate, the risk of tip-over.

---

Des blessures graves ou fatales peuvent résulter de basculement du meuble. Afin de prévenir le basculement :

- Il est important d'installer le crochet de sécurité inclus.
- Placer les items les plus lourds dans les espaces de rangement du bas.
- Ne jamais laisser un enfant grimper sur les tiroirs,
- les portes et les tablettes ou s'accrocher à ceux-ci.
- Ne jamais ouvrir plus d'un tiroir à la fois.
- Si un objet lourd est placé sur l'unité ou à l'intérieur, considérez le risque de basculement.

L'utilisation de dispositif antibasculement réduit les risques de basculement, sans les éliminer totalement.







---

El volcadura del mueble puede ser causa de lesiones graves o de un atropellamiento fatal. Para evitar la volcadura :

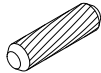

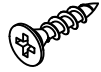
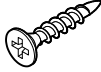

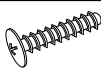
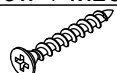
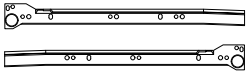
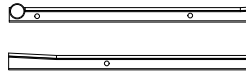

- Es importante instalar el gancho de seguridad.
- Ponga las cosas pesadas en los compartimentos más bajos.
- Nunca permita que un niño se suba o se cuelgue en cajones, puertas o estantes.
- Nunca abra más de un cajón a la vez.
- Si un objeto pesado está colocado dentro o sobre el mueble, considere
- el riesgo de que se puede voltear.

El uso de sujetadores para evitar la volcadura sólo puede disminuir el riesgo de una volcadura, pero no lo elimina.

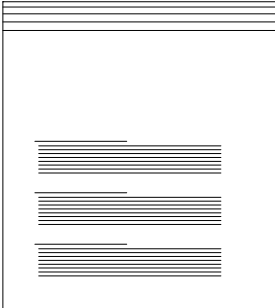
# HARDWARE QUINCAILLERIE / HERRAJE

(1) <i>Wood Dowel <math>\phi</math>8x30mm</i>  43 pcs	(2) <i>Minifix Bolt</i>  61 pcs	(3) <i>Minifix Cam</i>  61 pcs
(4) <i>Screw <math>\phi</math>3.5x15mm</i>  50 pcs	(5) <i>Screw <math>\phi</math>4x20mm</i>  40 pcs	(6) <i>PVC Block - 35mm</i>  20 pcs
(7) <i>Screw <math>\phi</math>4x38mm</i>  25 pcs	(8) <i>Handle - 96mm</i>  6 pcs	(9) <i>Handle Screw <math>\phi</math>4x19mm</i>  12 pcs
(10) <i>Screw <math>\phi</math>4x28mm</i>  20 pcs	(11) <i>Drawer Slide 12"</i>  5 sets	(12) <i>Drawer Slide 12"</i>  5 sets



## FURNITURE TIPPING RESTRAINT SEGURO CONTRA VOLCADO DE MUEBLES DISPOSITIF DE SÉCURITÉ POUR MEUBLES

 x 1	(13) <i>Mounting L-Bracket</i>  1 pc	(14) <i>Flat Washer <math>\phi</math>6x16mm</i>  1 pc
	(15) <i>Screw #10x16mm</i>  1 pc	(16) <i>Screw <math>\phi</math>4x38mm</i>  1 pc

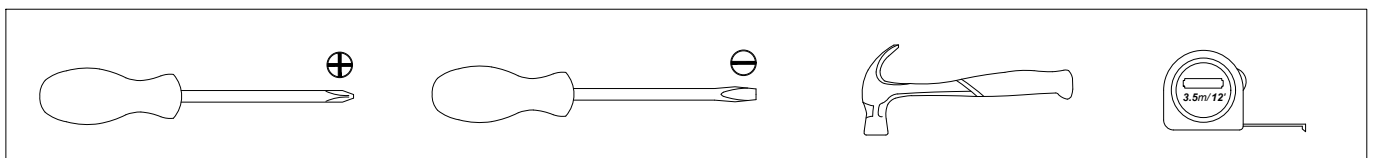
## TOOLS NOT INCLUDED OUTILS PAS INCLUS / HERRAMIENTAS NO INCLUIDAS



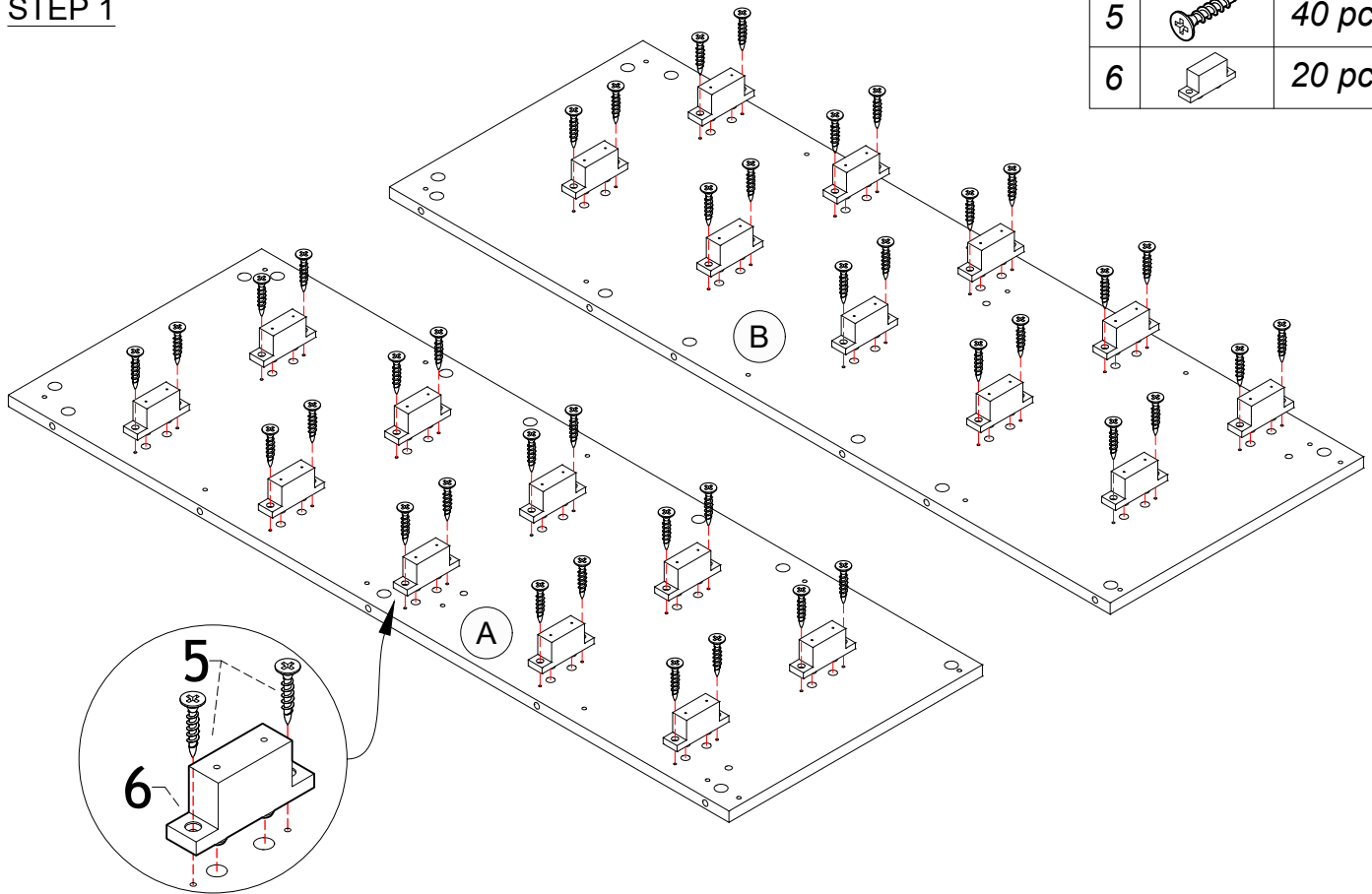

## STEP 1

5		40 pcs
6		20 pcs



## STEP 2

4		30 pcs
11		5 sets

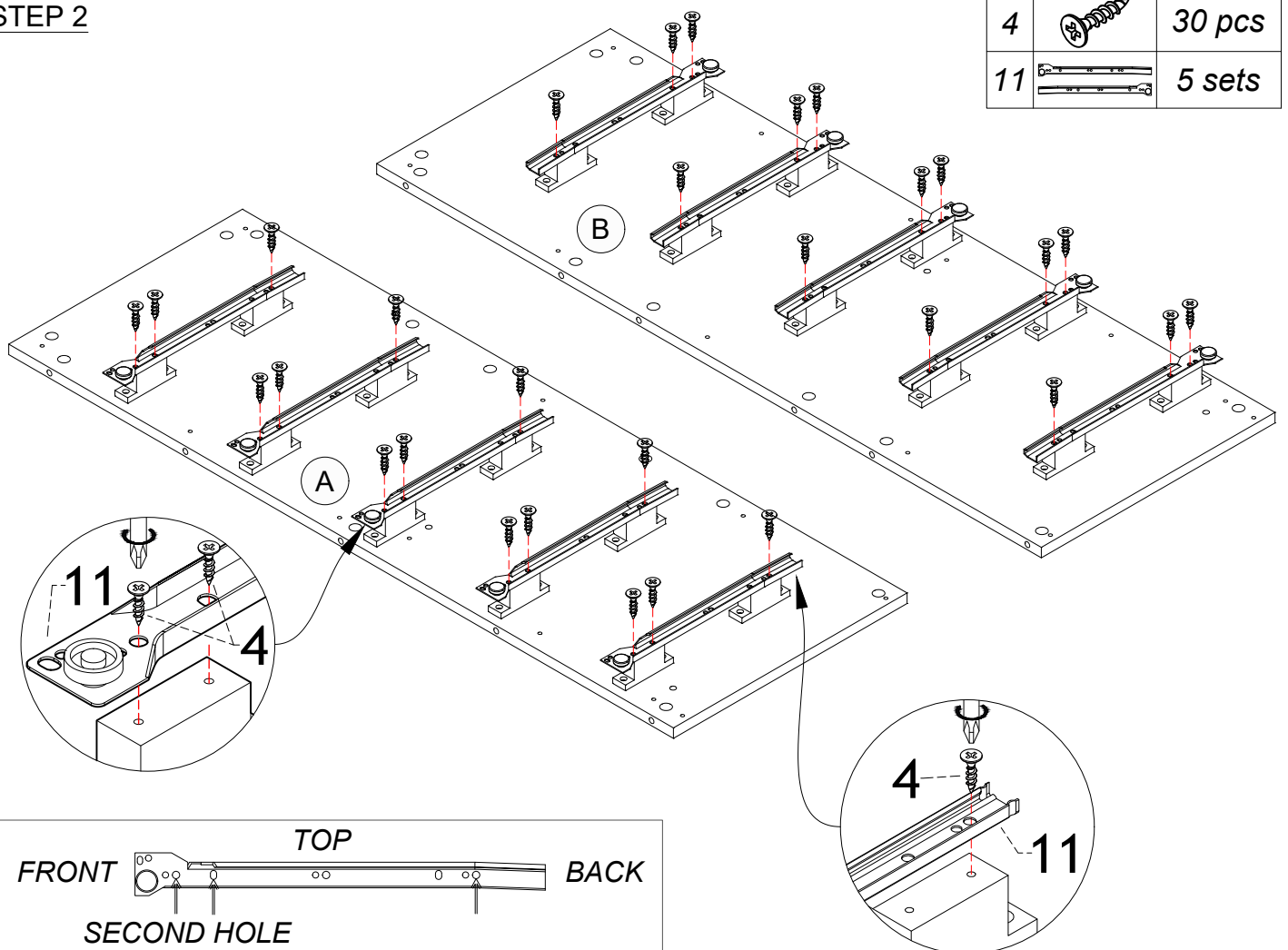

PLEASE ENSURE TO FIX THE SCREWS AS PER ABOVE POINTED HOLES INSTRUCTION TO AVOID DISTORTION OF OVERALL LOOK OF PRODUCTS

**STEP 3**

2		4 pcs
---	--	-------

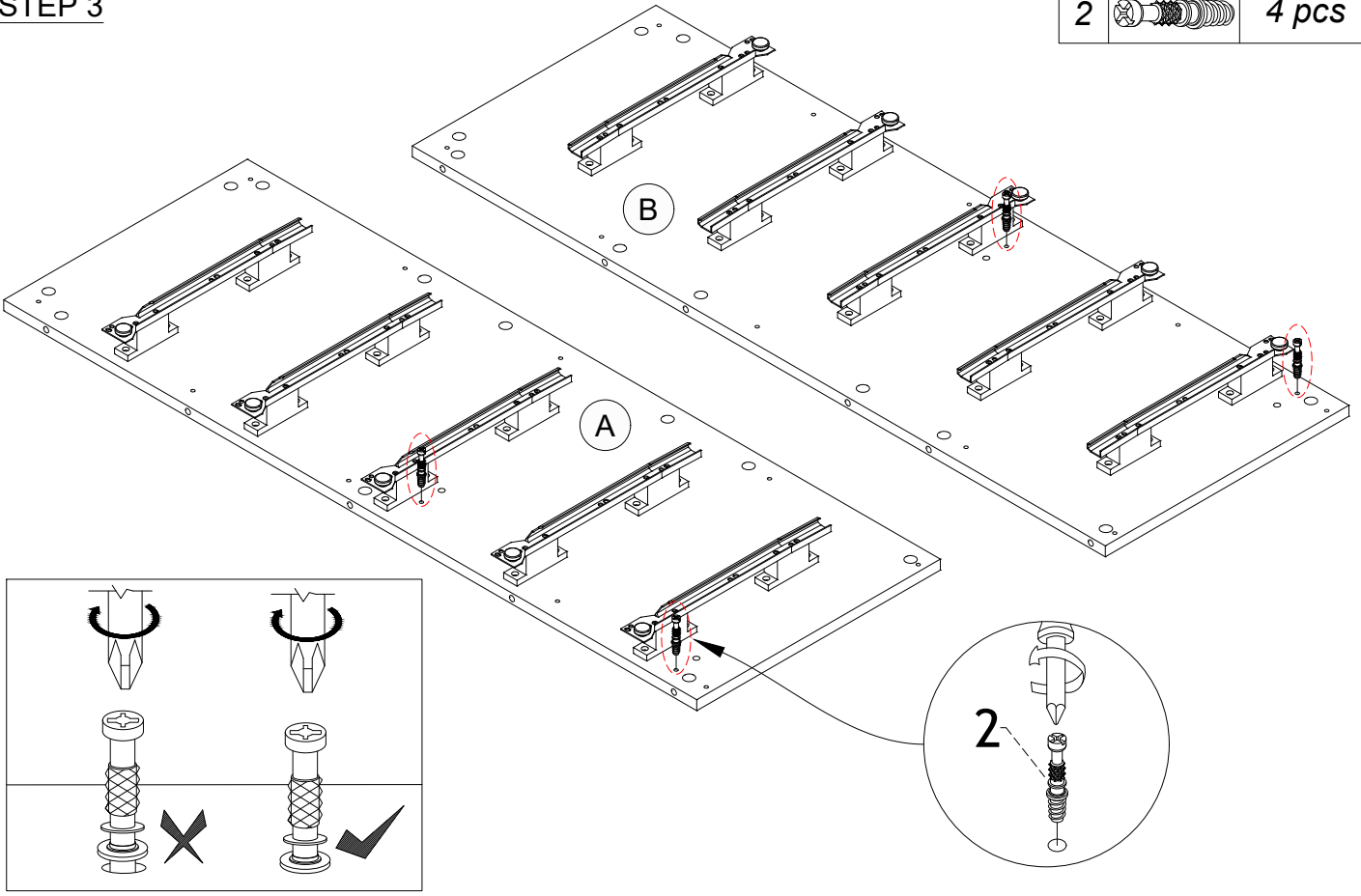

**STEP 4**

1		4 pcs
---	---	-------

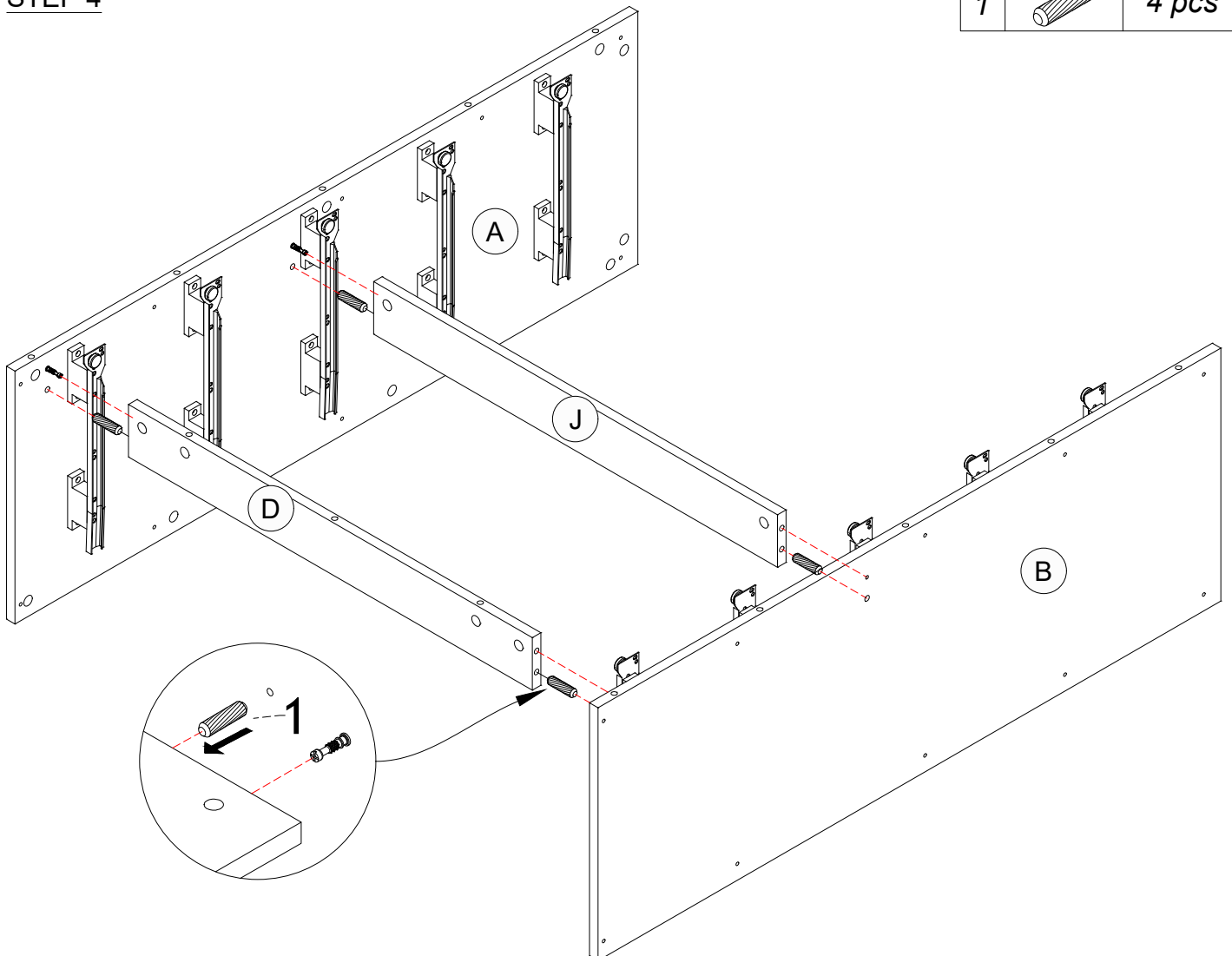

STEP 5

3  4 pcs

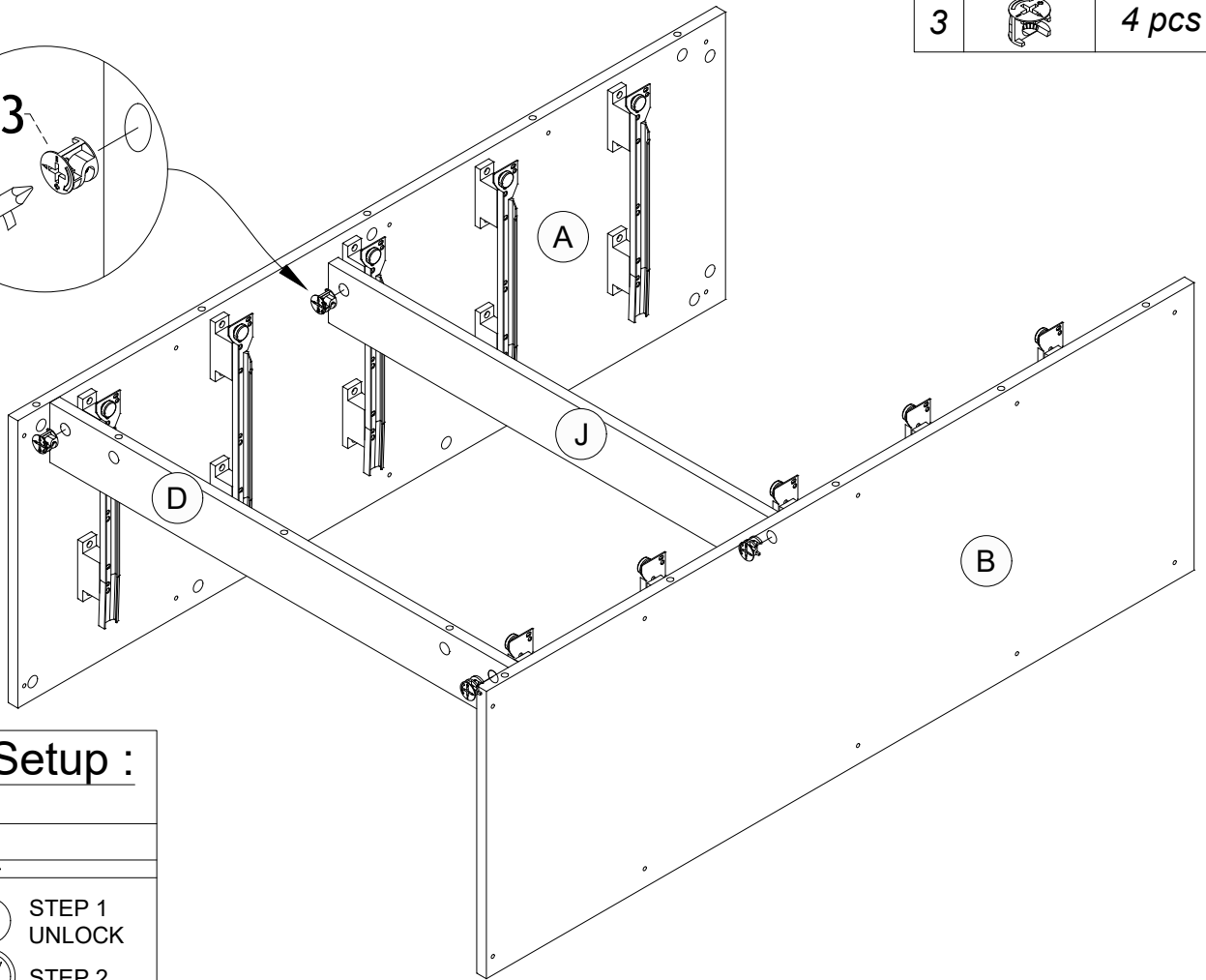
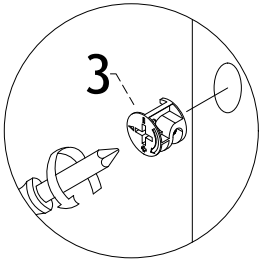

Minifix Setup :



STEP 1  
UNLOCK



STEP 2



STEP 3  
LOCK

STEP 6

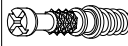
2  12 pcs

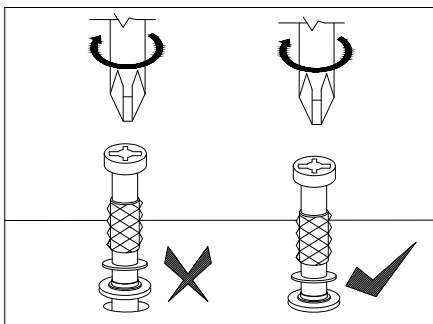
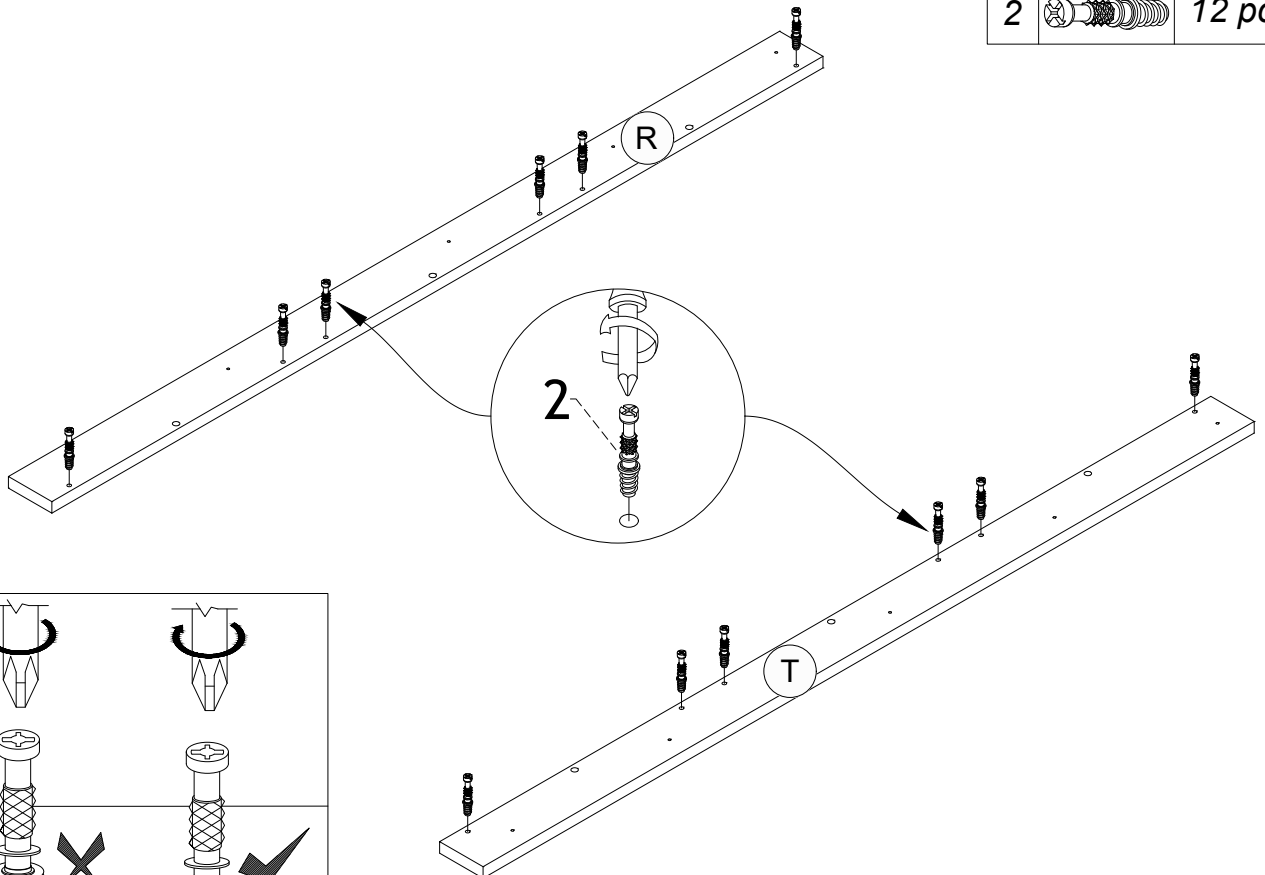

**STEP 7**



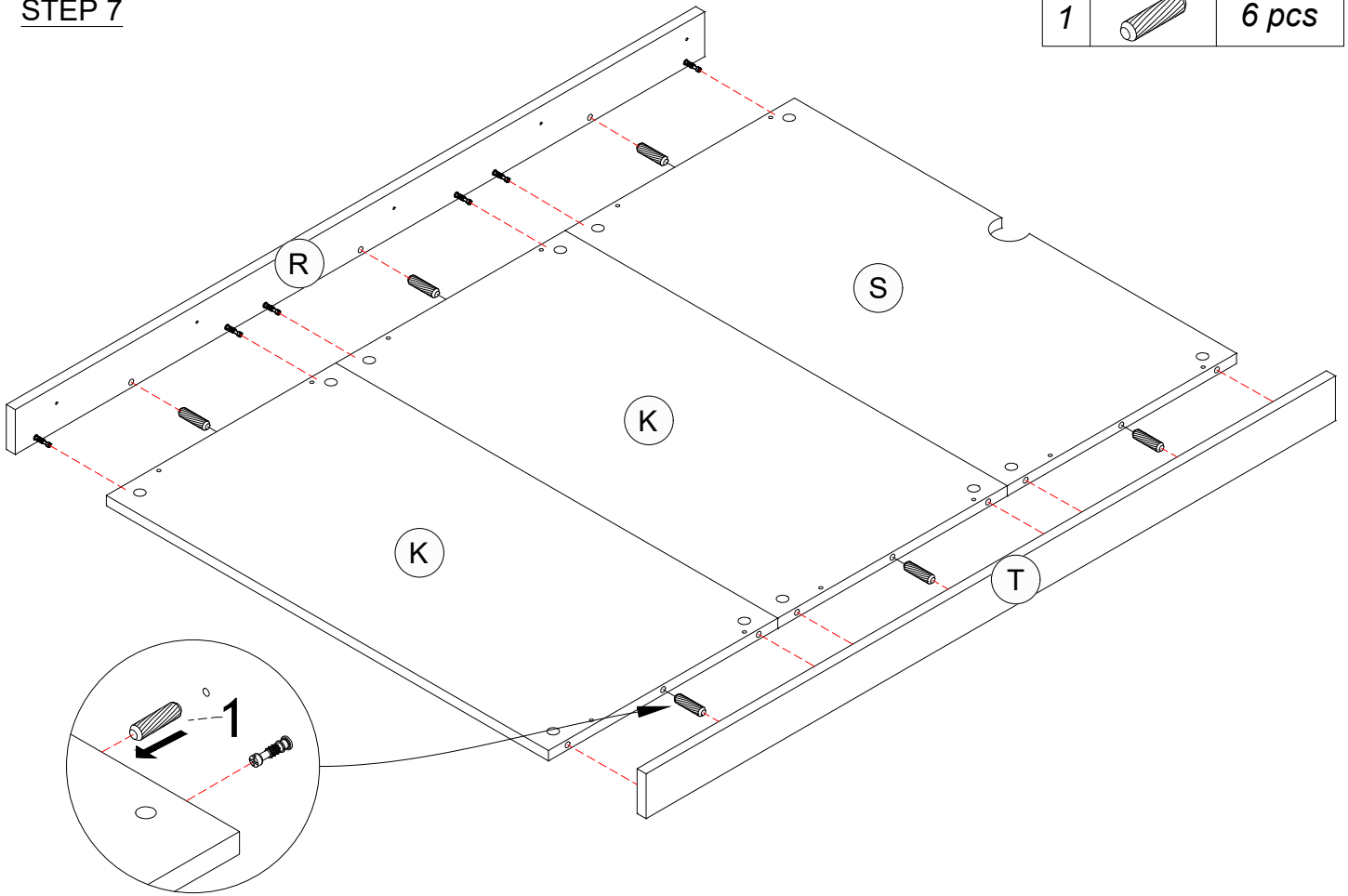

1		6 pcs
---	--	-------

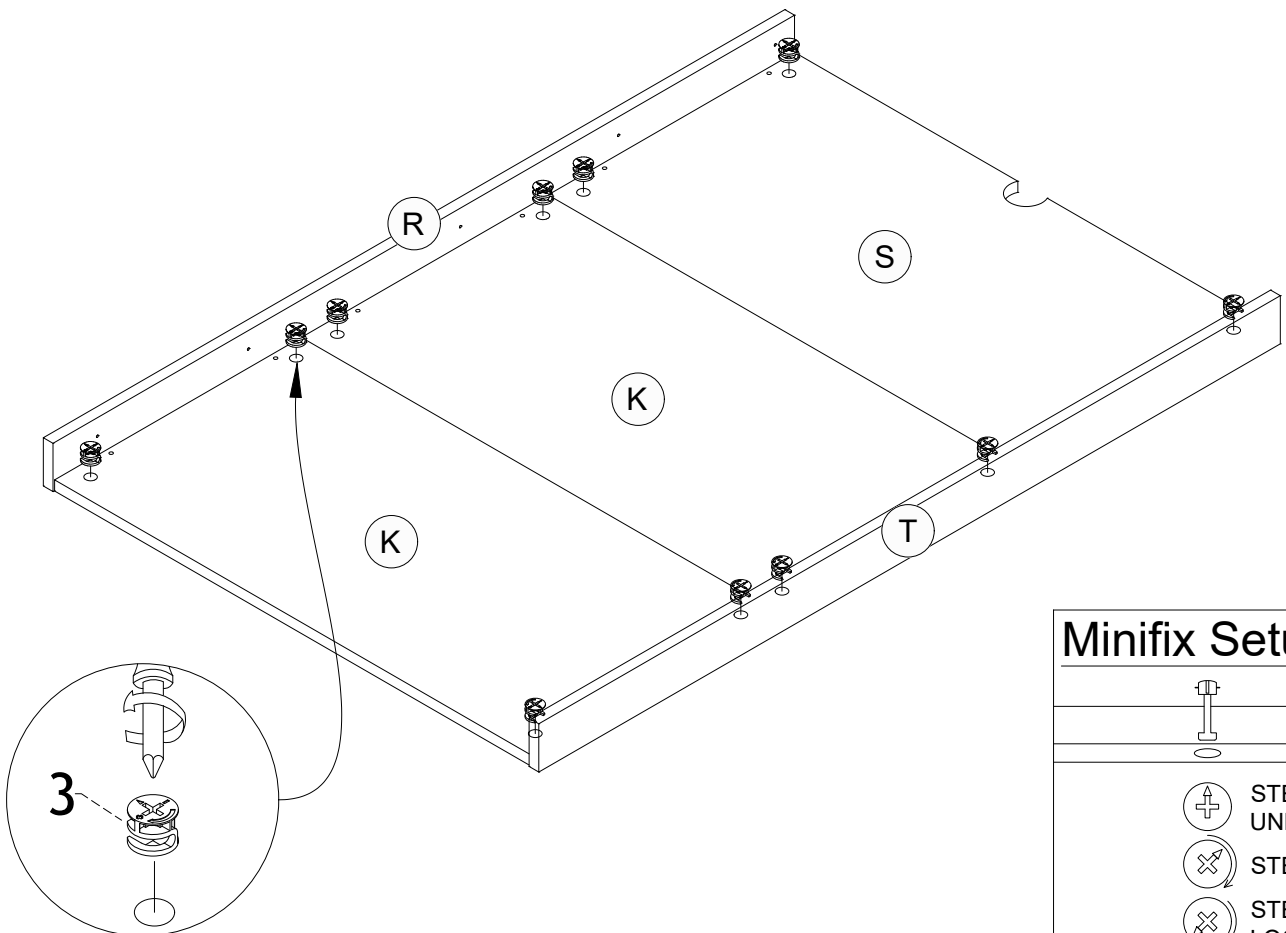

**STEP 8**

3		12 pcs
---	---	--------



<b>Minifix Setup :</b>	
	
	STEP 1 UNLOCK
	STEP 2
	STEP 3 LOCK



**STEP 9**

2  12 pcs

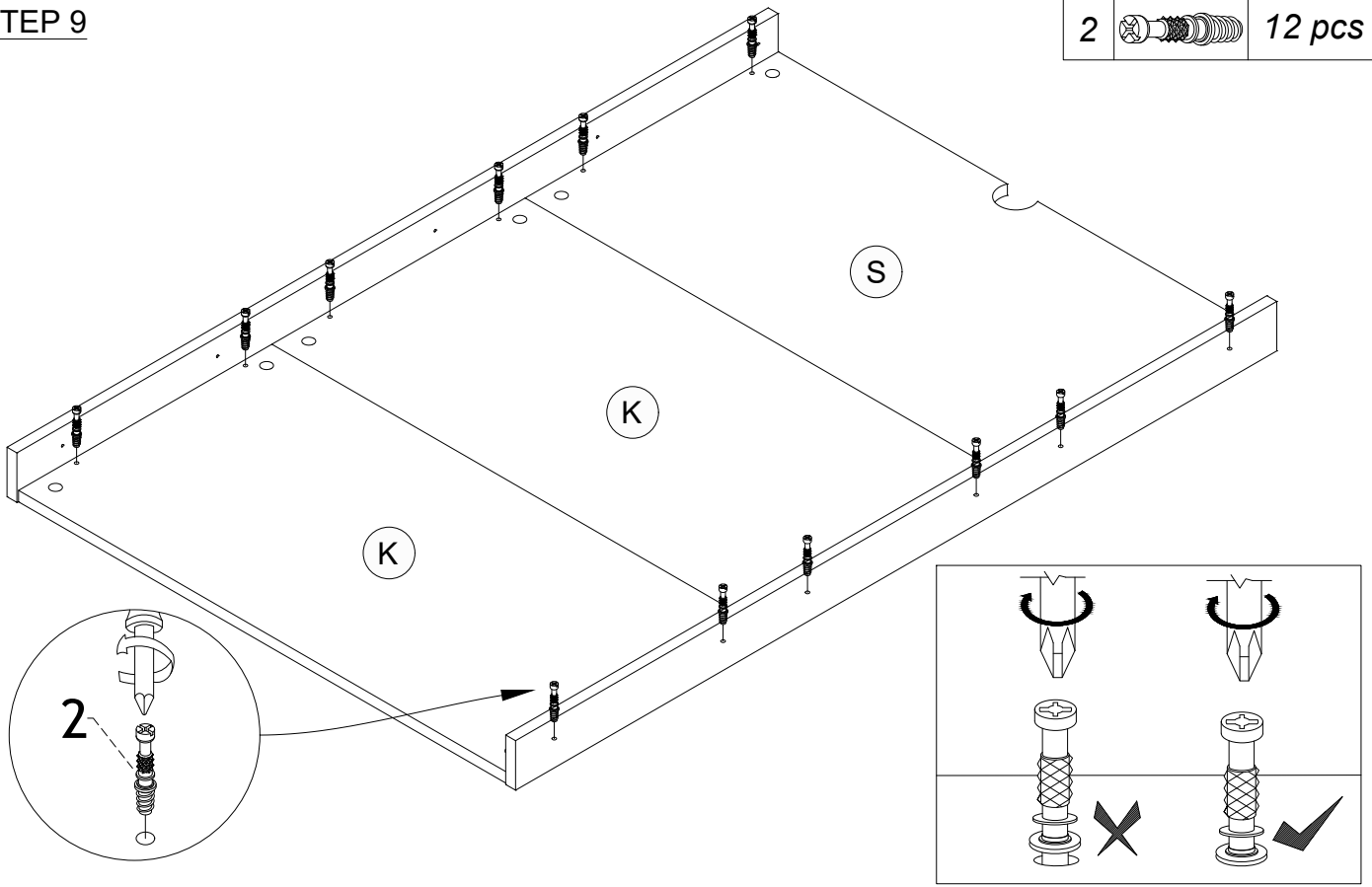

**STEP 10**

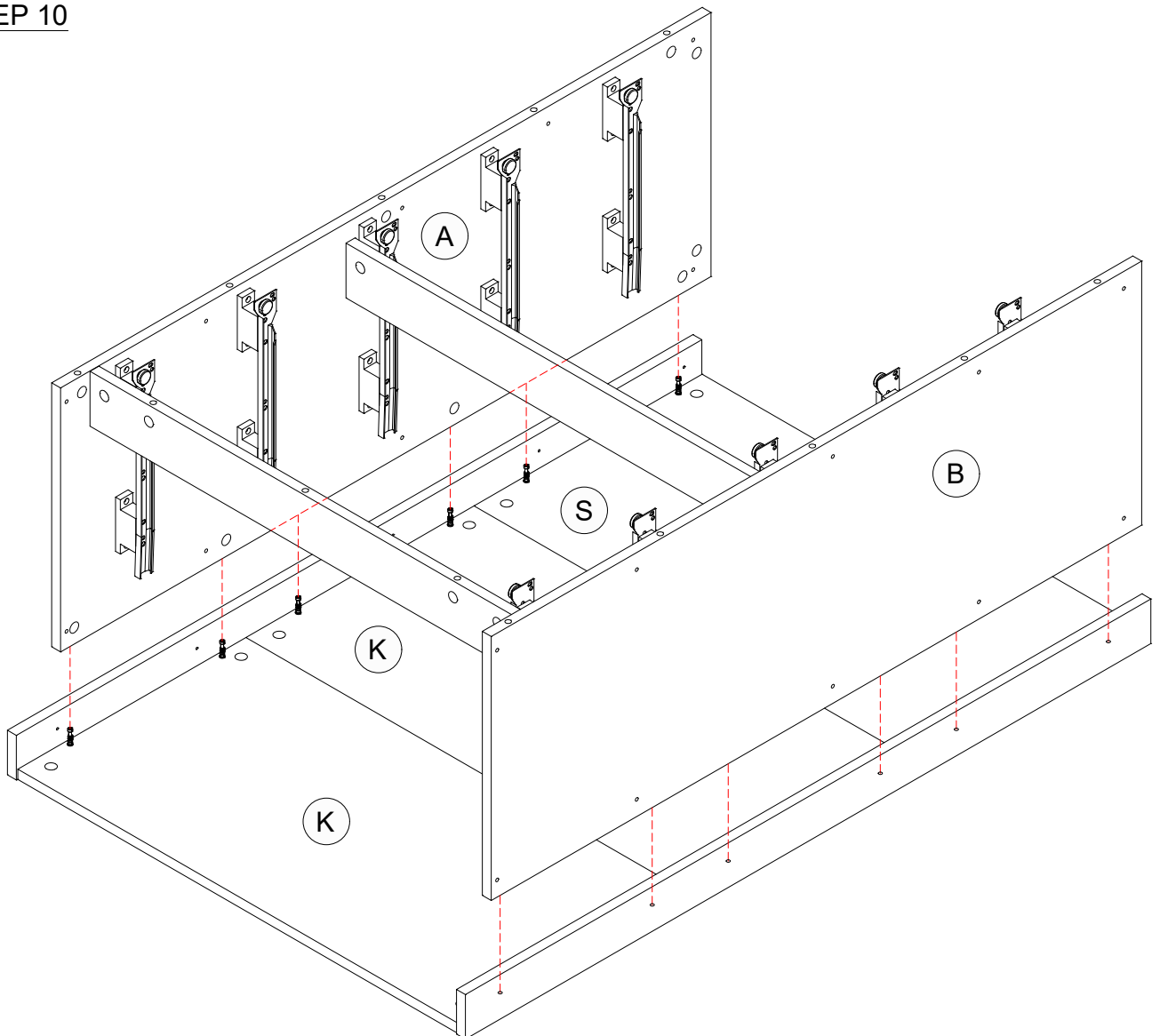



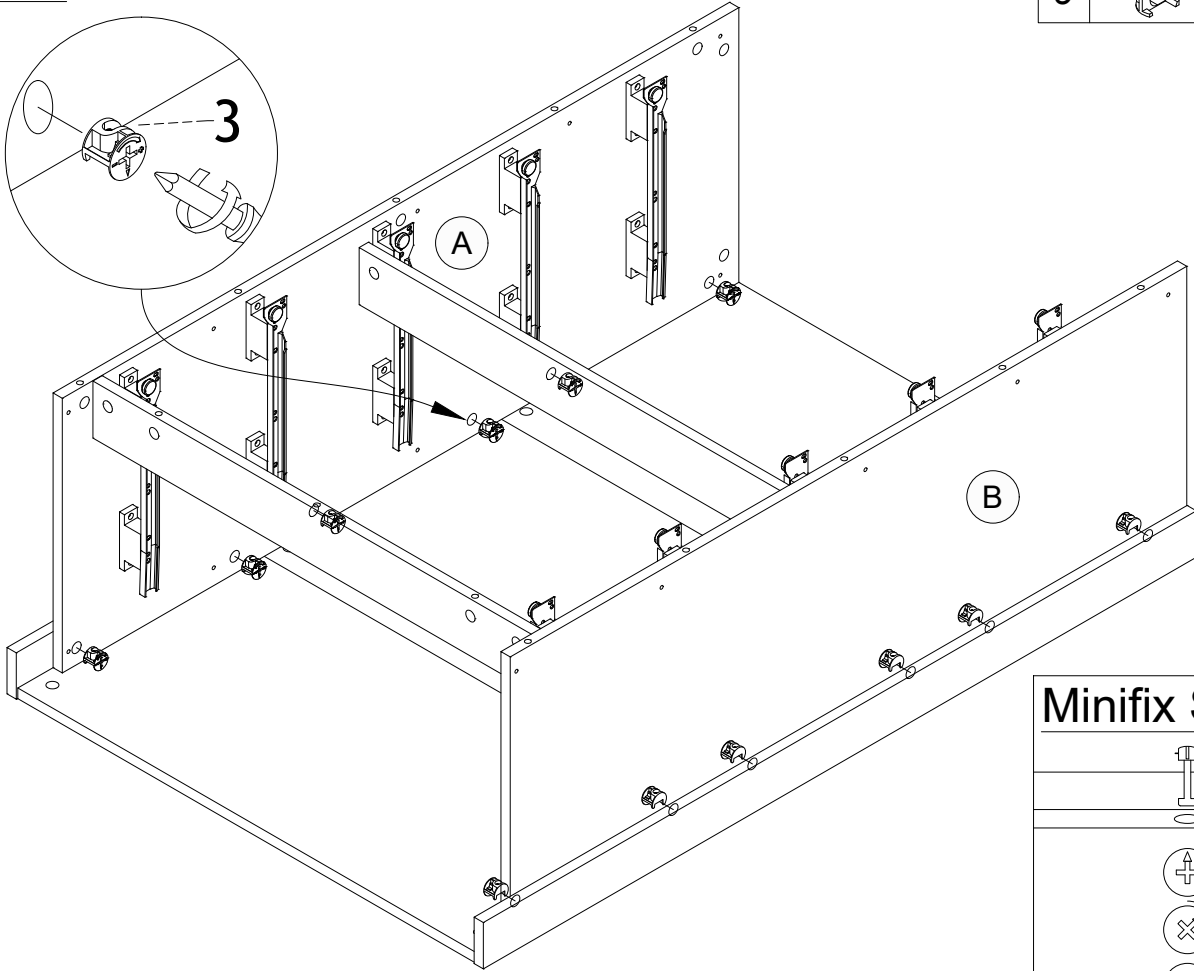

STEP 11

3  12 pcs



**Minifix Setup :**

	
	STEP 1 UNLOCK
	STEP 2 LOCK
	STEP 3 LOCK

STEP 12

10  10 pcs

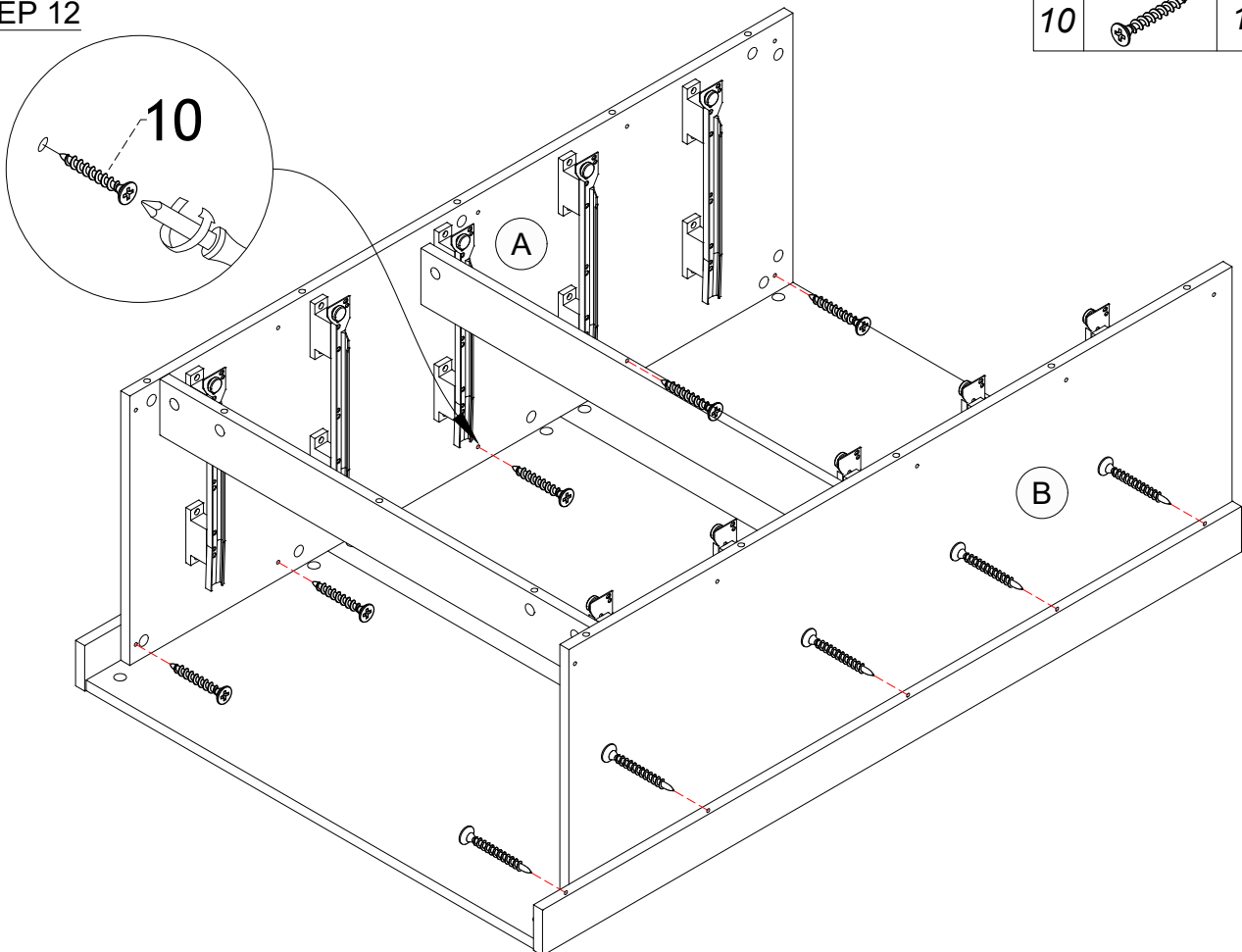

STEP 13

2		12 pcs
---	--	--------

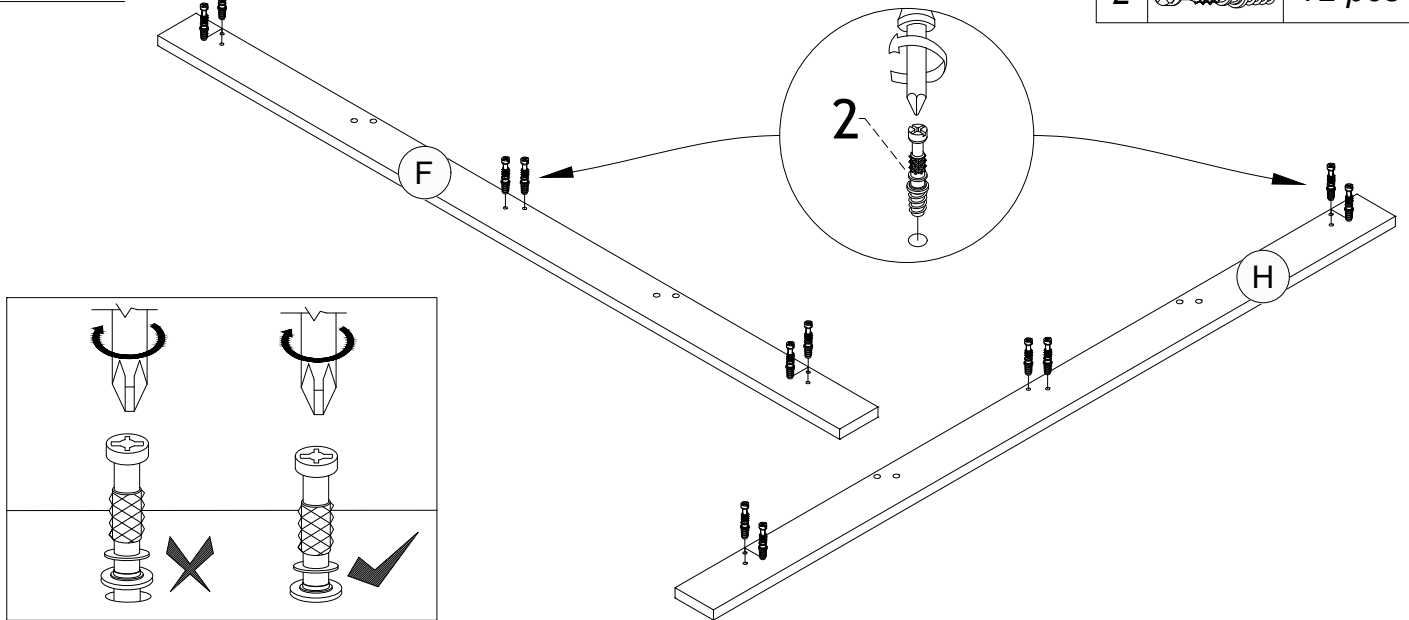

STEP 14

1		4 pcs
---	---	-------

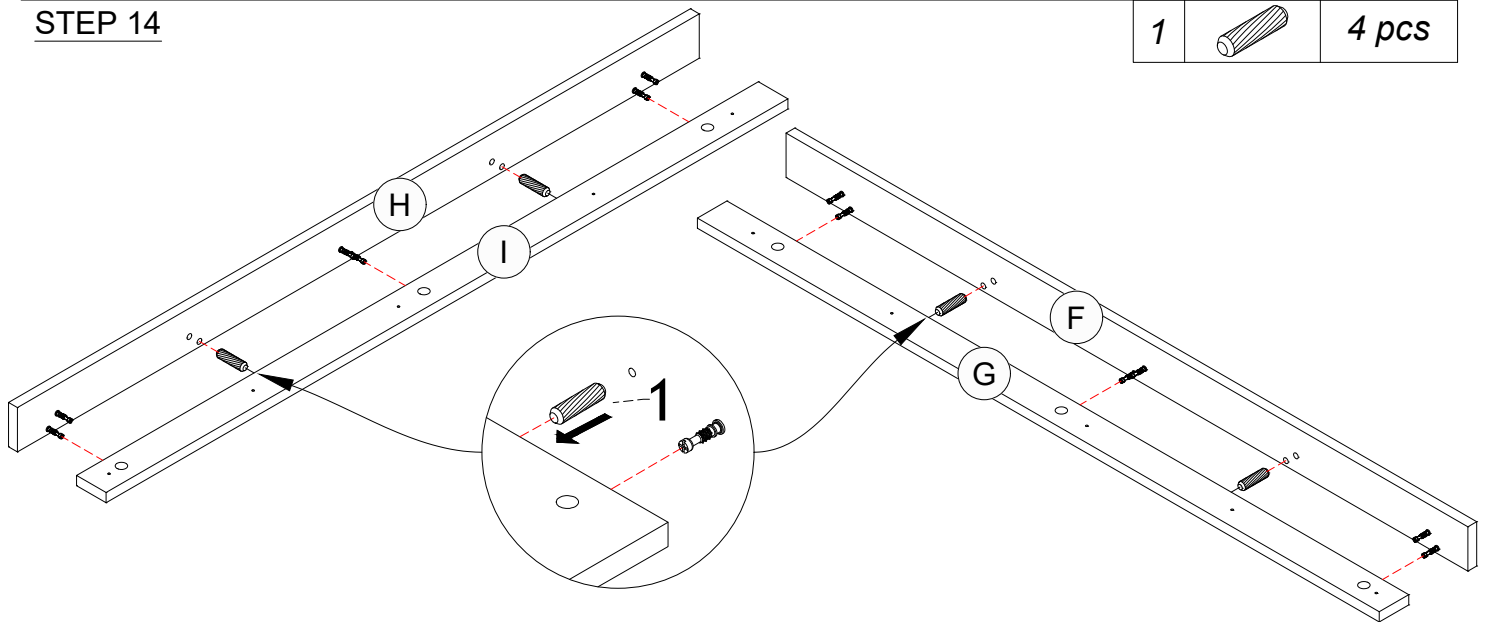



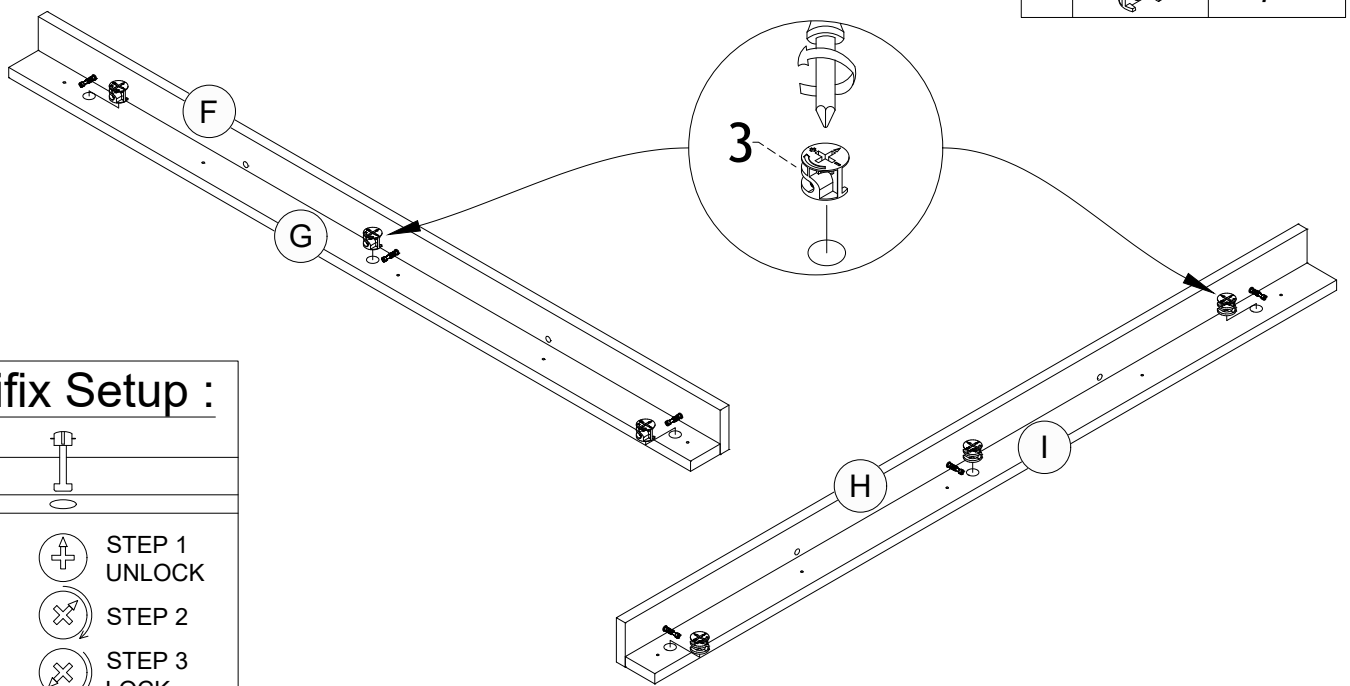

STEP 15

3		6 pcs
---	---	-------



**Minifix Setup :**

	
	STEP 1 UNLOCK
	STEP 2
	STEP 3 LOCK

STEP 16

1		4 pcs
---	--	-------

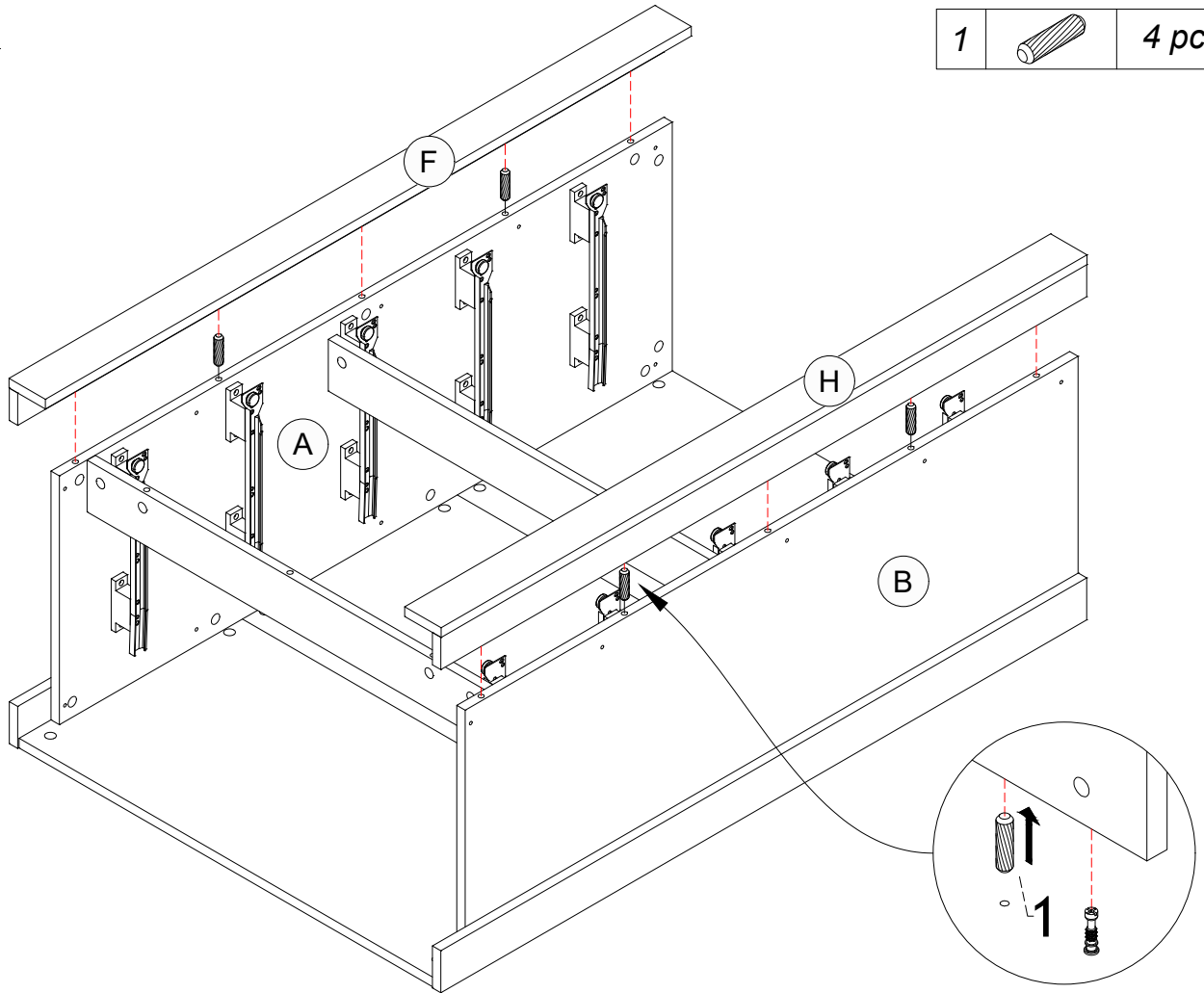



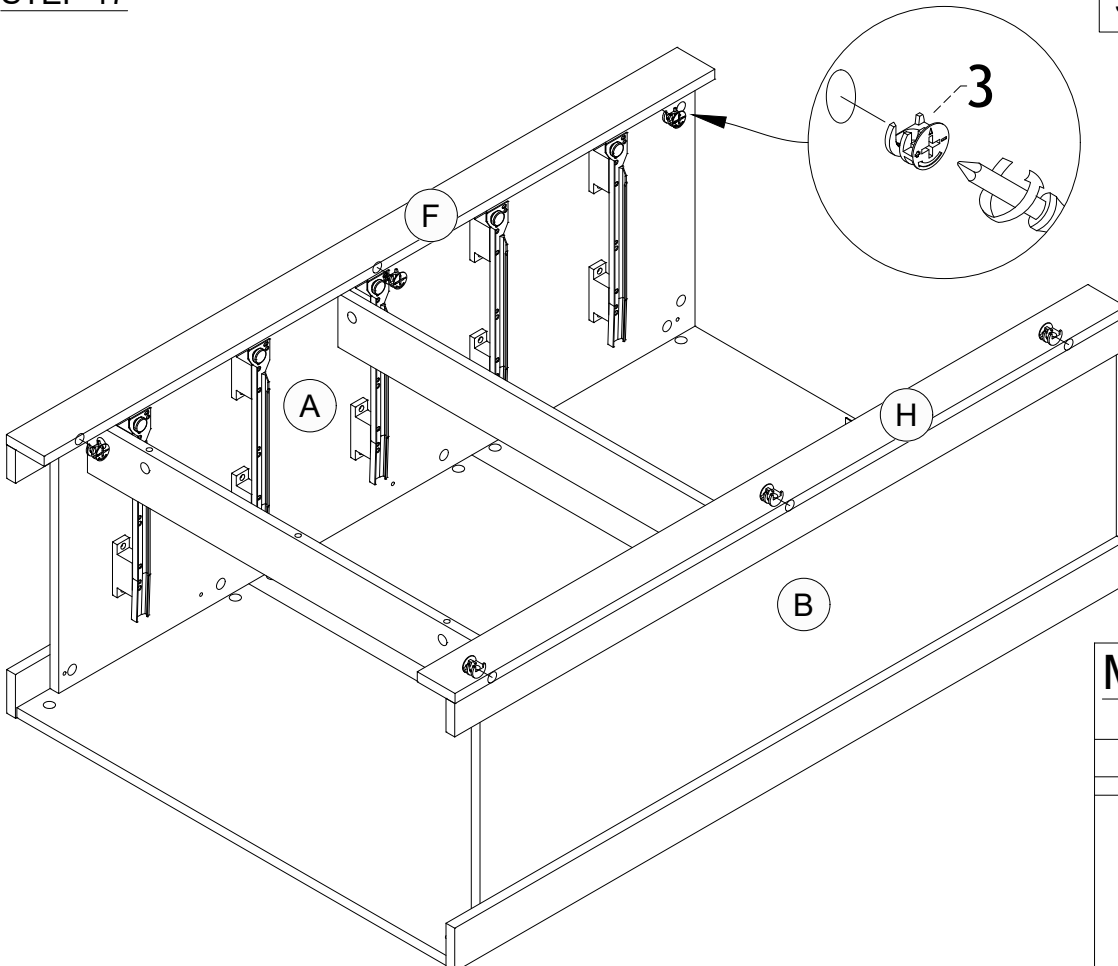

STEP 17

3		6 pcs
---	---	-------



**Minifix Setup :**

	
	STEP 1 UNLOCK
	STEP 2
	STEP 3 LOCK

STEP 18

10		10 pcs
----	--	--------

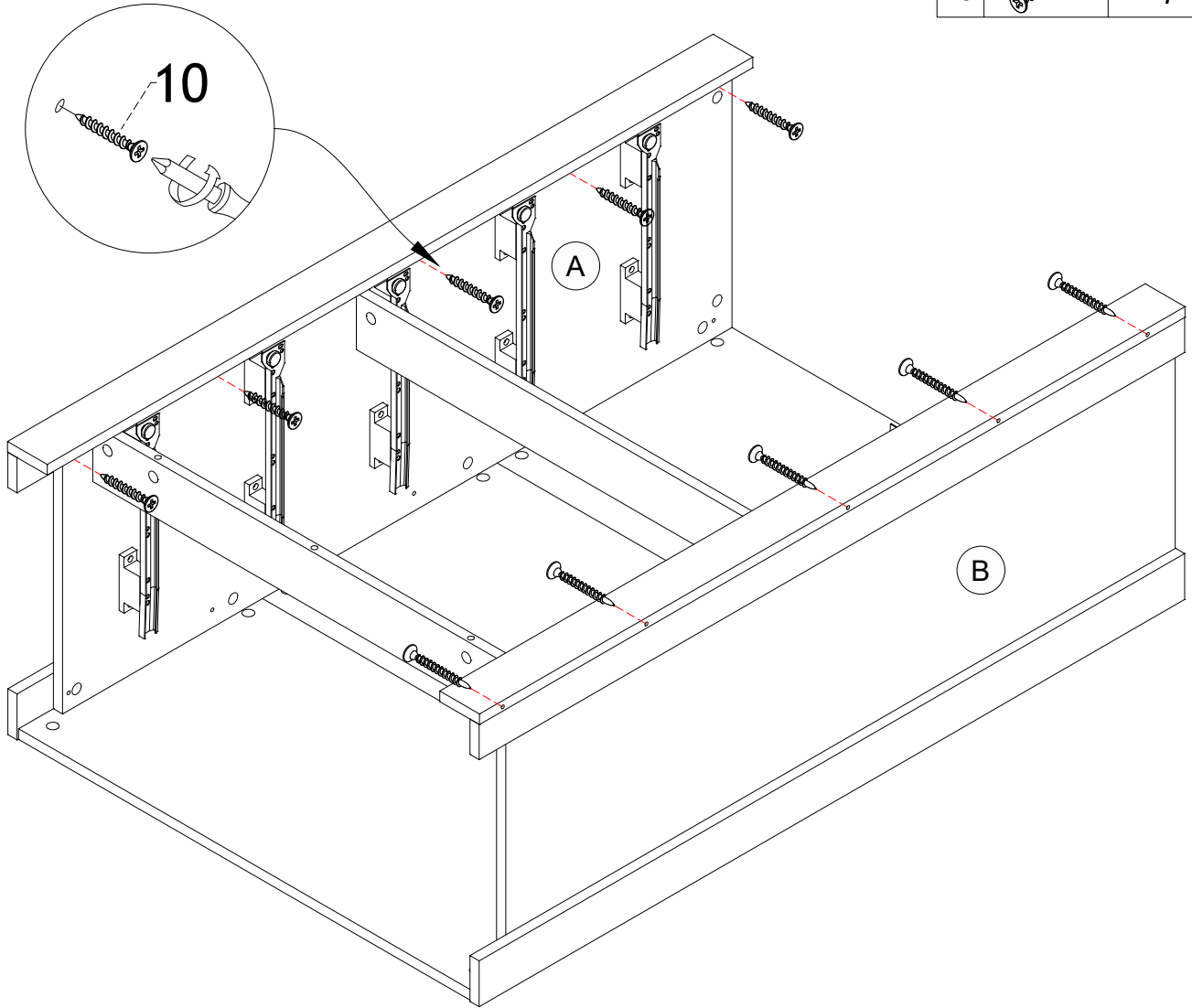

STEP 19

2		2 pcs
---	---	-------

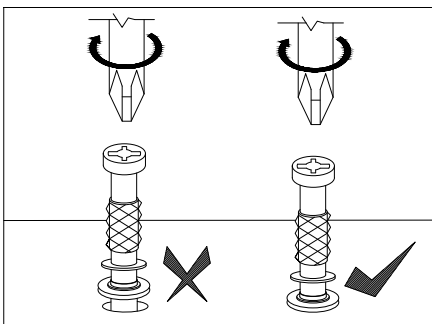
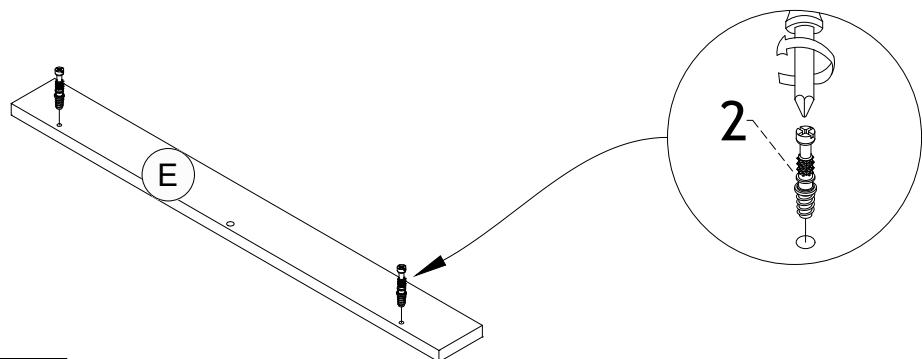

STEP 20



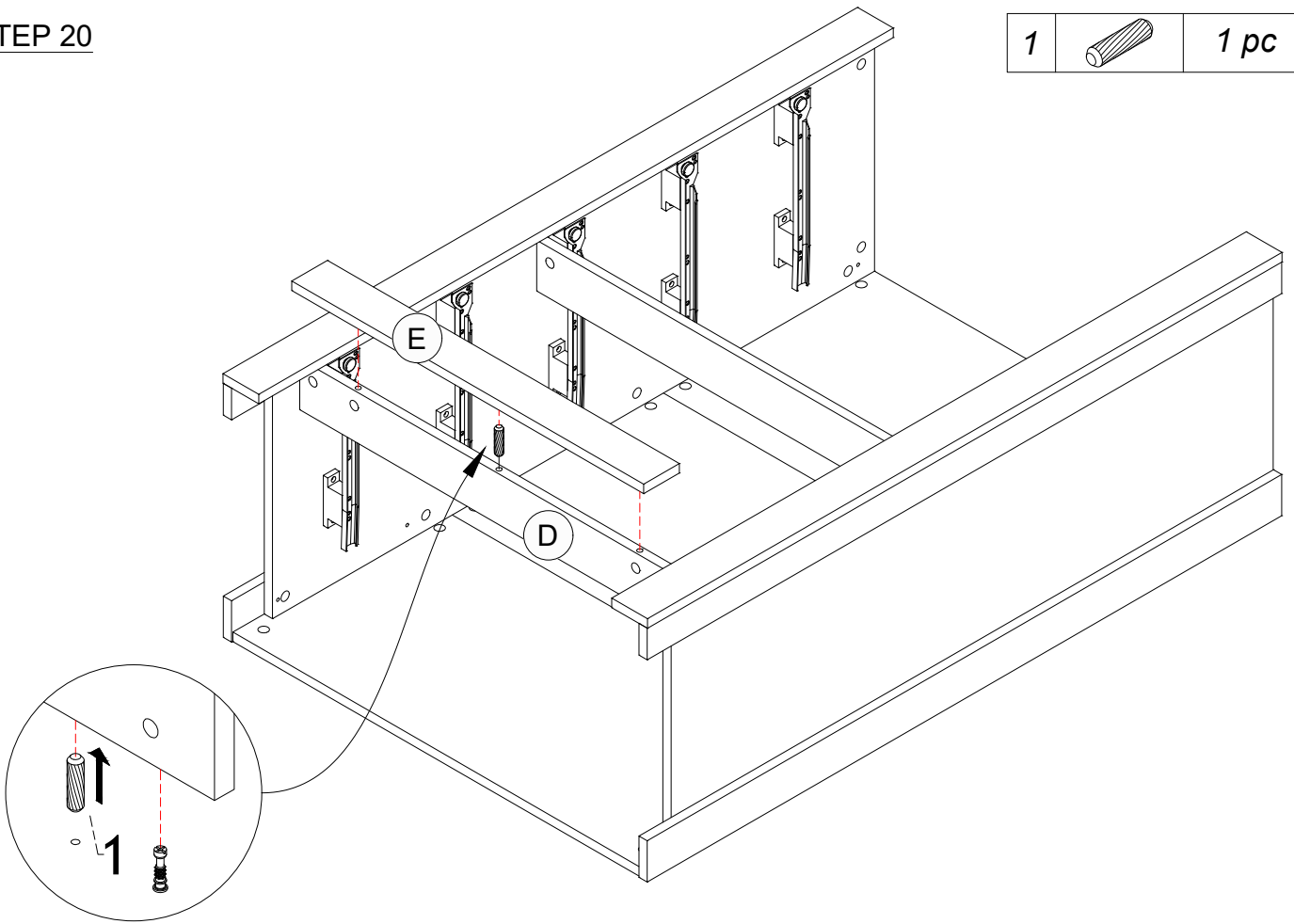

1		1 pc
---	--	------



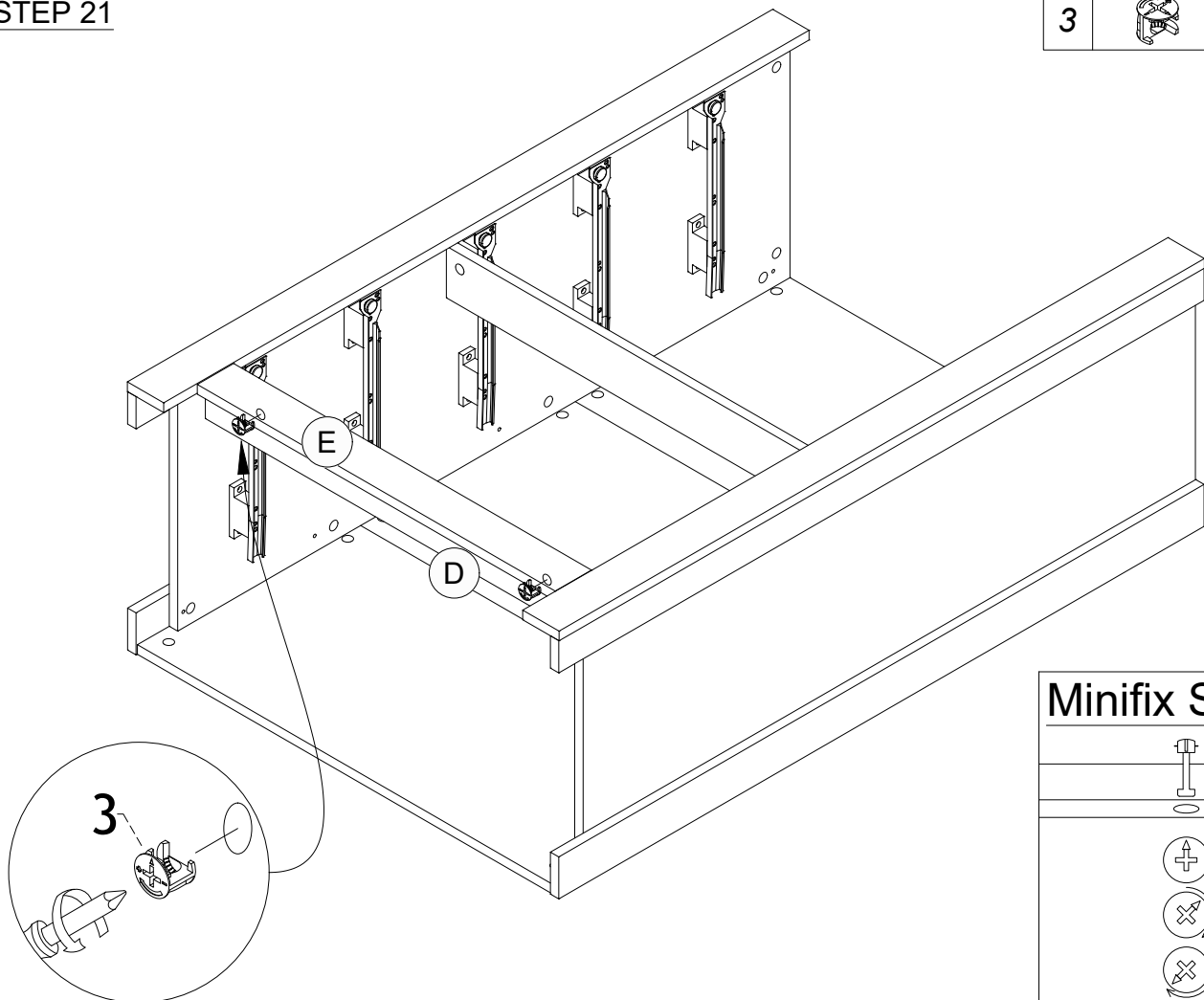



STEP 21

3		2 pcs
---	---	-------



<b>Minifix Setup :</b>	
	
	STEP 1 UNLOCK
	STEP 2
	STEP 3 LOCK

STEP 22

2		4 pcs
13		1 pc
14		1 pc
15		1 pc

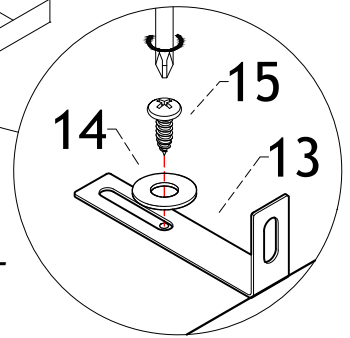
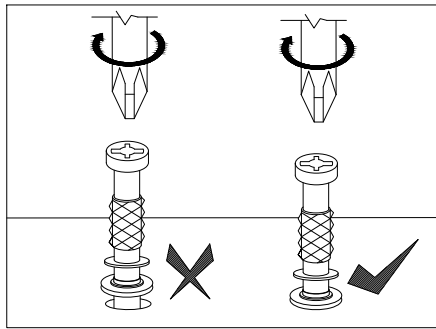
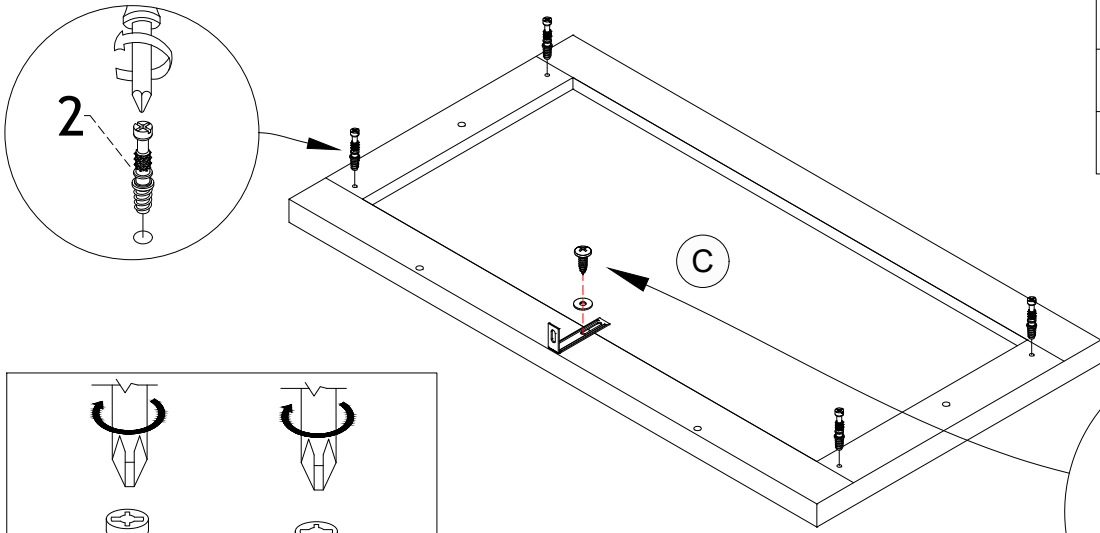

DO NOT FIT TOO TIGHT.

STEP 23

1		4 pcs
---	---	-------

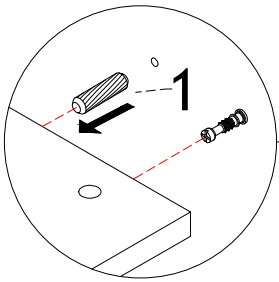
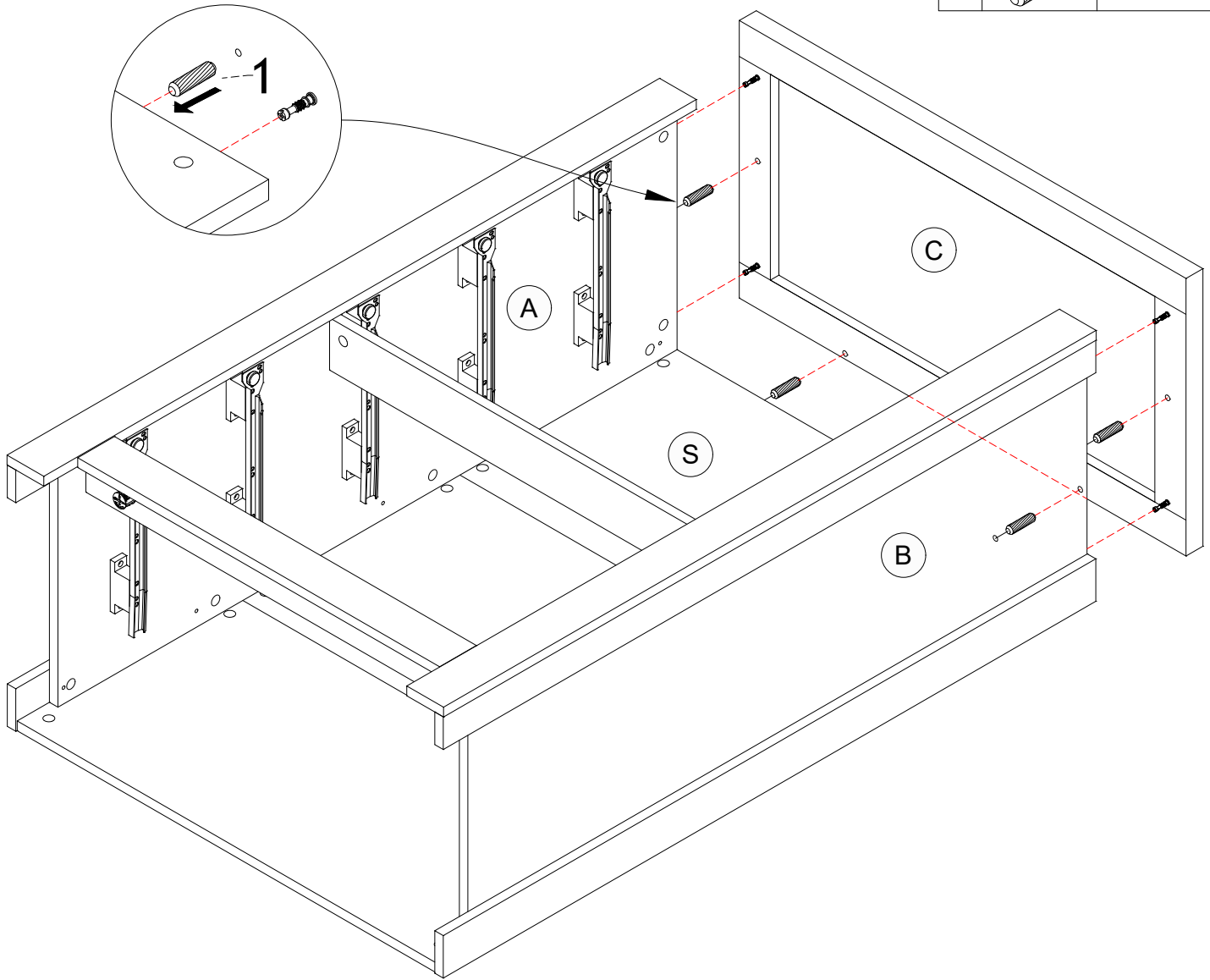



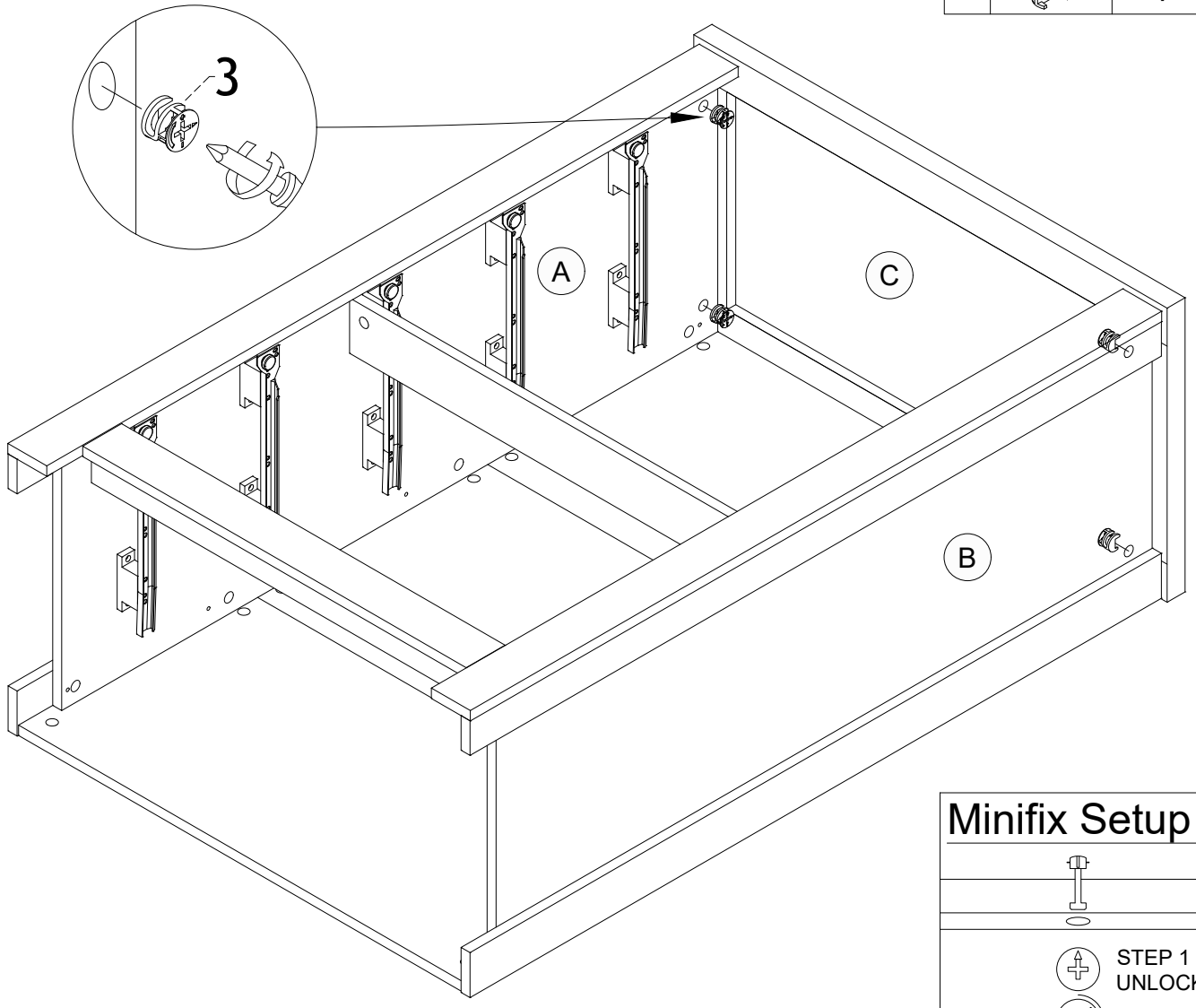

STEP 24

3		4 pcs
---	--	-------



**Minifix Setup :**

	
	STEP 1 UNLOCK
	STEP 2
	STEP 3 LOCK

STEP 25

2		15 pcs
---	---	--------

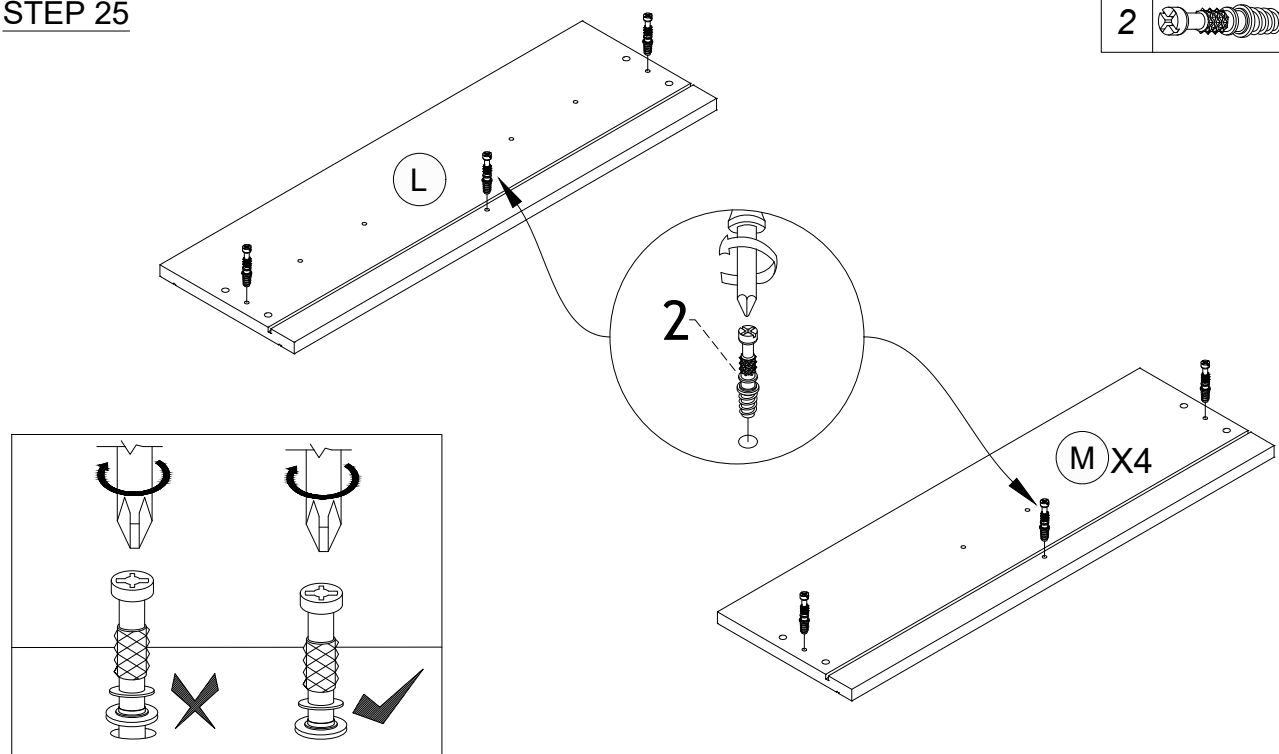

(5x)



STEP 26

1		20 pcs
---	--	--------

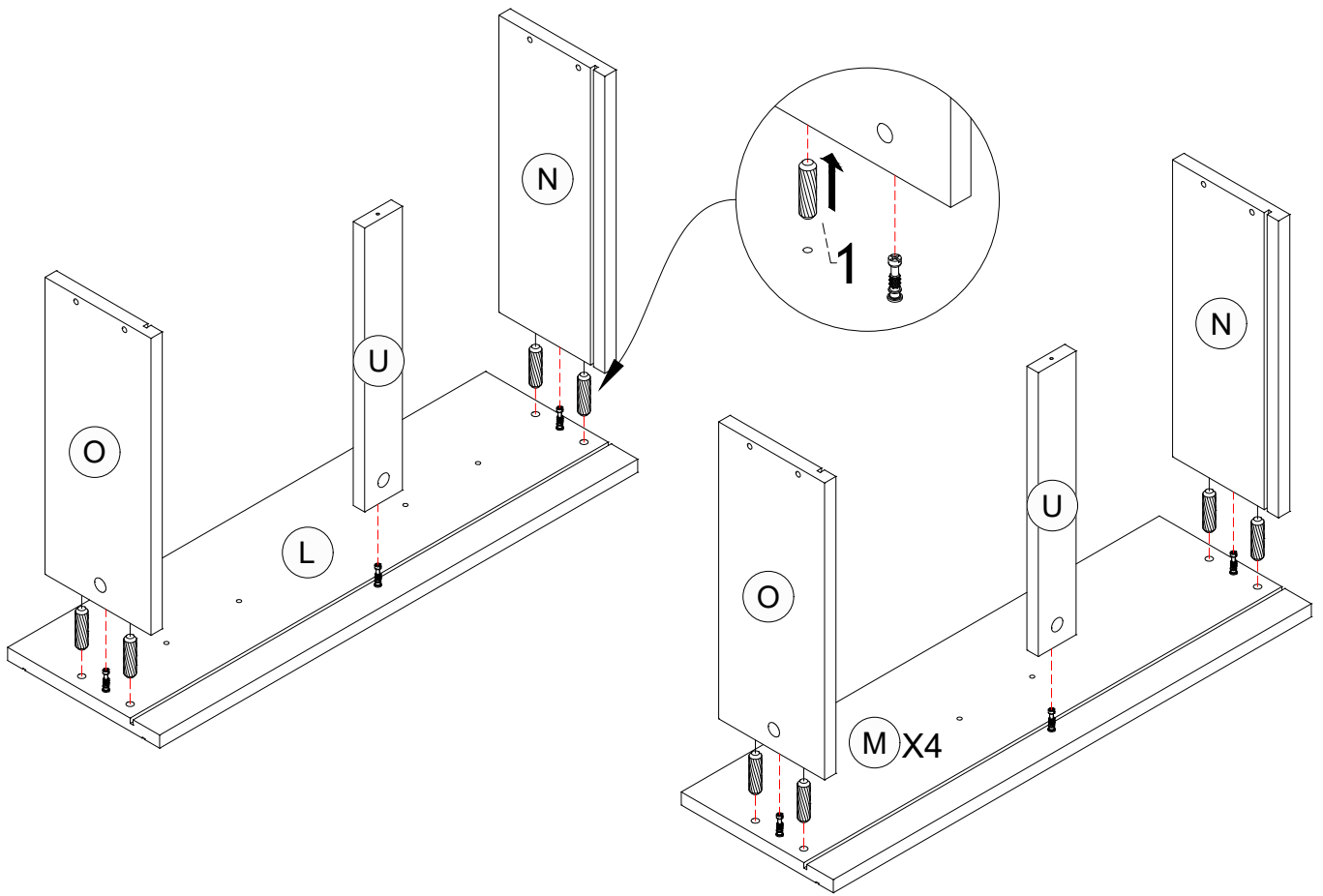

(5x)

STEP 27

3		15 pcs
---	---	--------

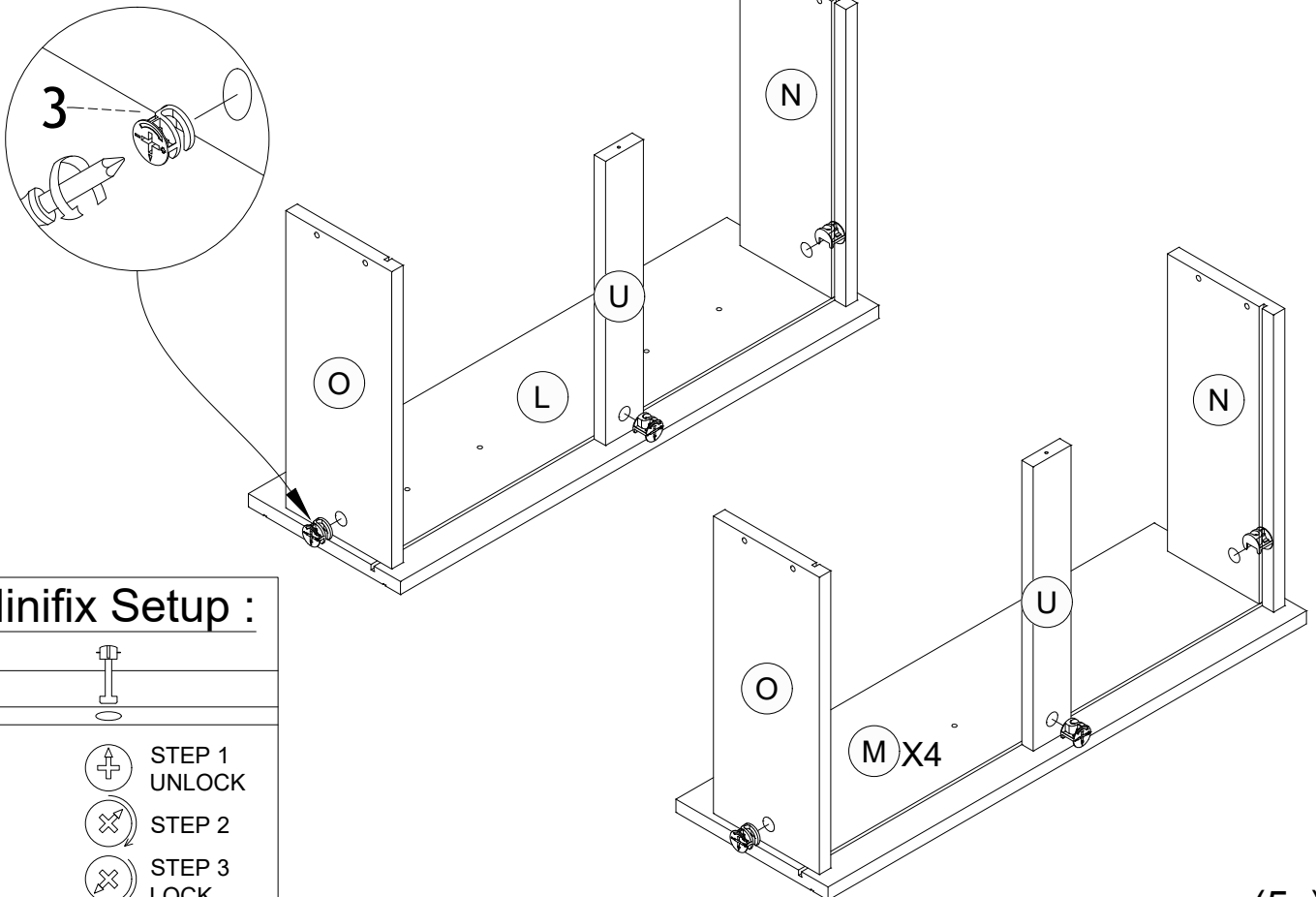

(5x)

Minifix Setup :



-  STEP 1  
UNLOCK
-  STEP 2
-  STEP 3  
LOCK

STEP 28

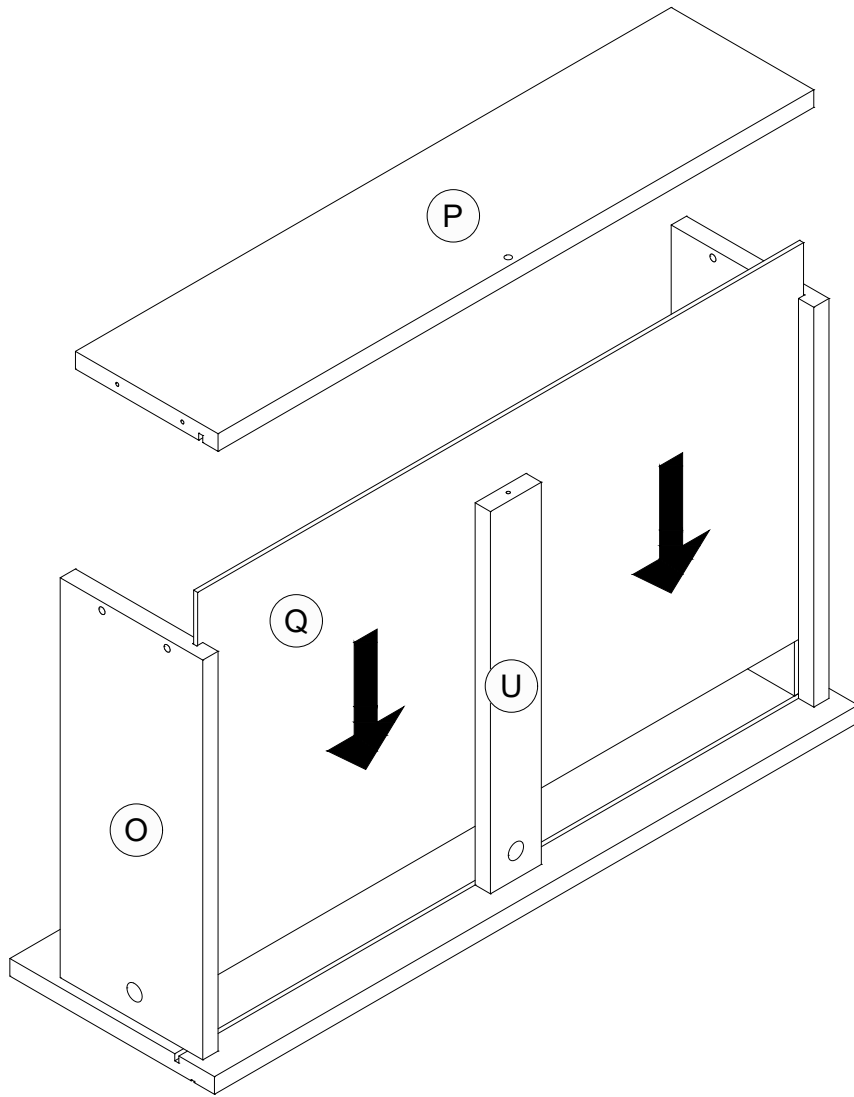

(5x)

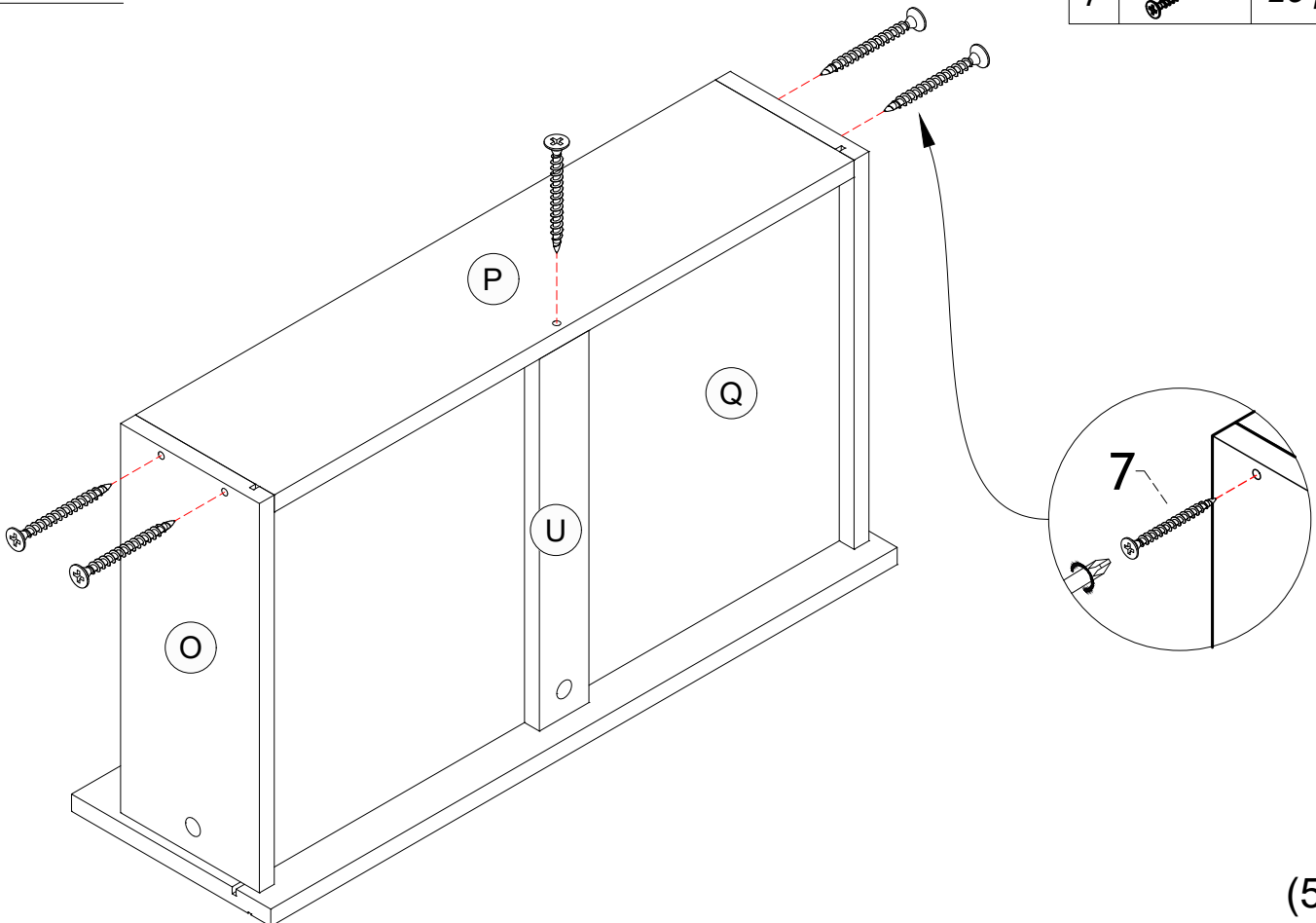

STEP 29

7		25 pcs
---	---	--------





(5x)

STEP 30

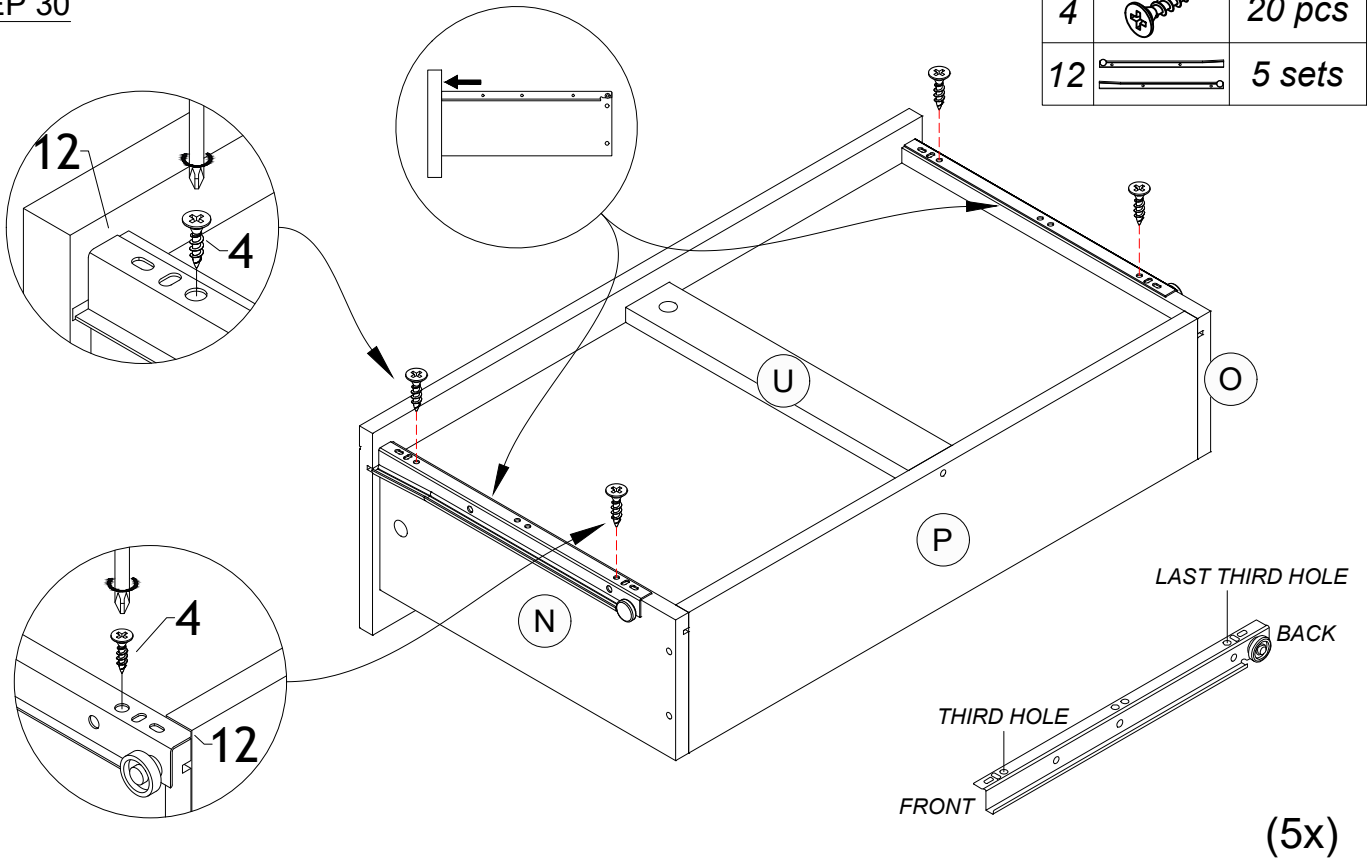
4		20 pcs
12		5 sets



STEP 31

8		6 pcs
9		12 pcs

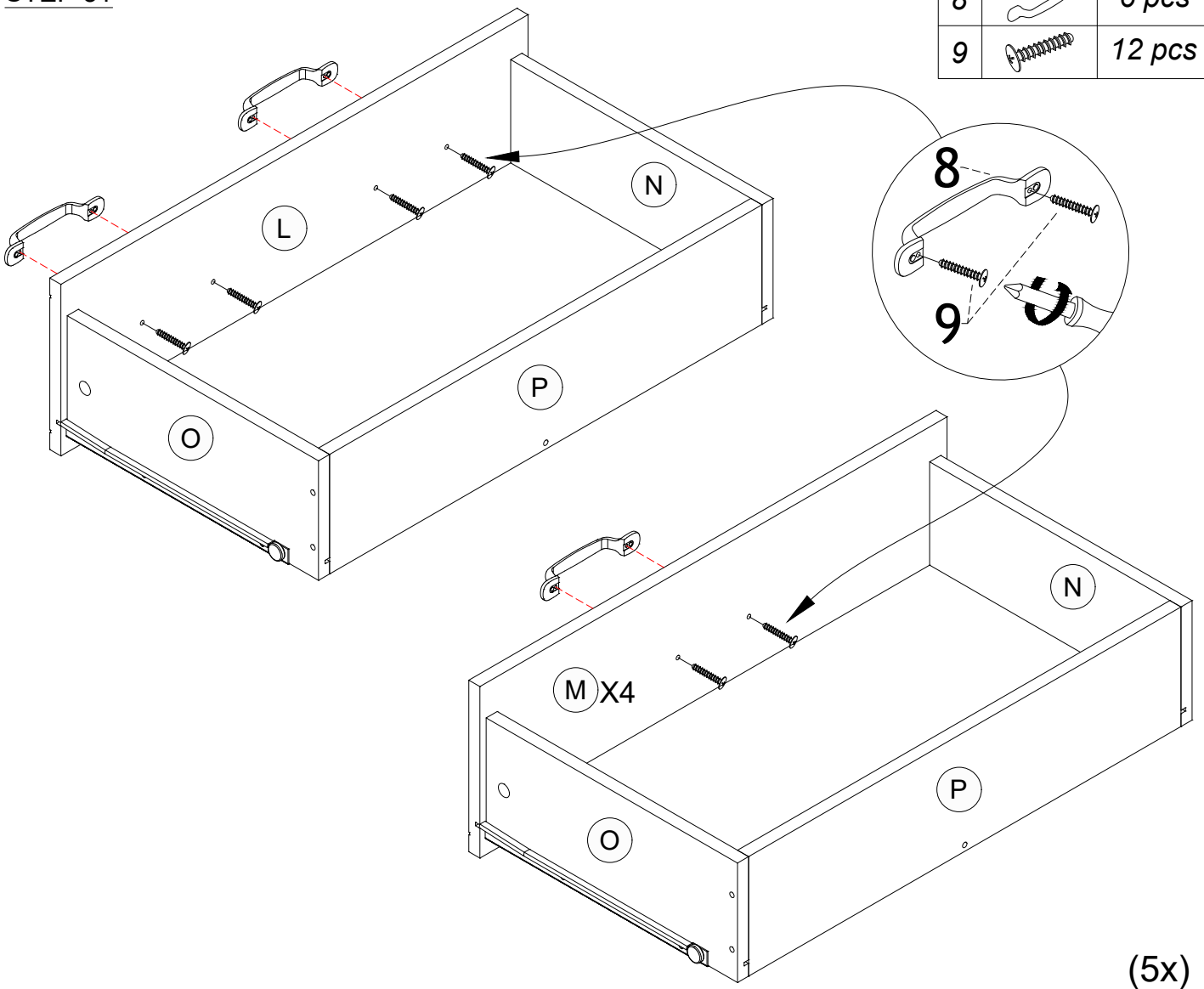

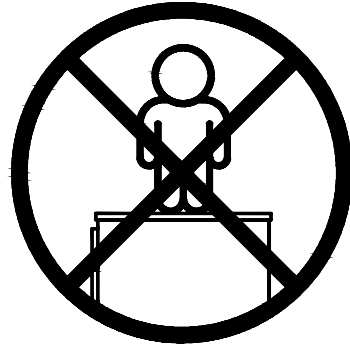
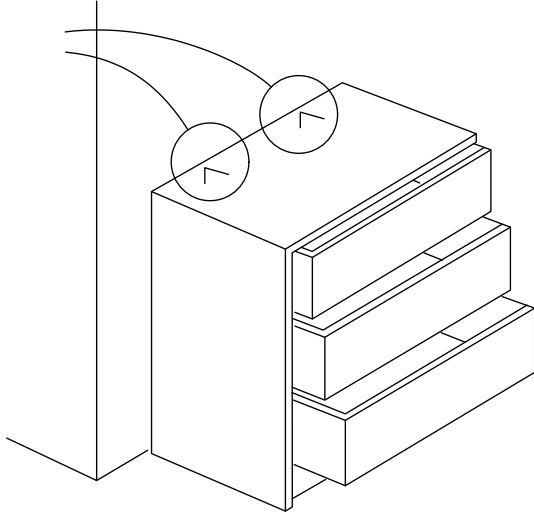

---

**IMPORTANT: THIS UNIT MUST BE SECURE TO THE WALL TO HELP PREVENT TIPOVER. FOLLOW THESE INSTRUCTIONS TO INSTALL THE ANTI-TIPPING SAFETY BRACKET PROVIDED WITH THIS PRODUCT.**

**IMPORTANTE: ESTA UNIDAD DEBE ESTAR SEGURA A LA PARED PARA AYUDAR A PREVENIR EL TIPOVER. SIGA ESTAS INSTRUCCIONES PARA INSTALAR EL SOPORTE DE SEGURIDAD ANTI-TIPPING PROPORCIONADO CON ESTE PRODUCTO.**

**IMPORTANT : CETTE UNITÉ DOIT ÊTRE SÉCURITAIRE JUSQU'AU MUR POUR AIDER À PRÉVENIR LA BASCULEMENT. SUIVEZ CES INSTRUCTIONS POUR INSTALLER LE SUPPORT DE SÉCURITÉ ANTI-BASCULEMENT FOURNI AVEC CE PRODUIT.**



STEP 32

16		1 pc
----	--	------

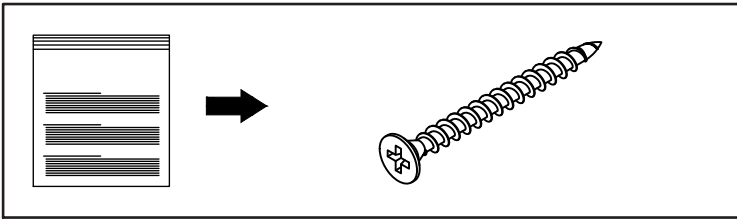

**Drywall anchor that supplied with this product is general purpose wall plug only.**

Consult your local hardware store for appropriate anchors for the type of wall you intend to securely attach the safety bracket.

**Ancla de paneles de yeso que se suministra con este producto es enchufe de pared de propósito general solamente.**

Consulte a su ferretería local para obtener los anclajes adecuados para el tipo de muro que desea fijar el soporte de seguridad.

**Ancre de cloison sèche qui a fourni avec ce produit est prise de mur d'usage général seulement.**

Consultez votre quincaillerie locale pour trouver des ancrs appropriées pour le type de mur que vous avez l'intention de attacher le support de sécurité.

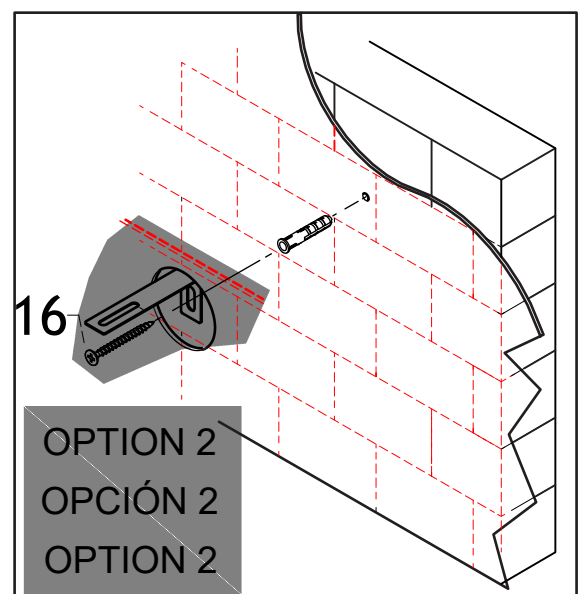
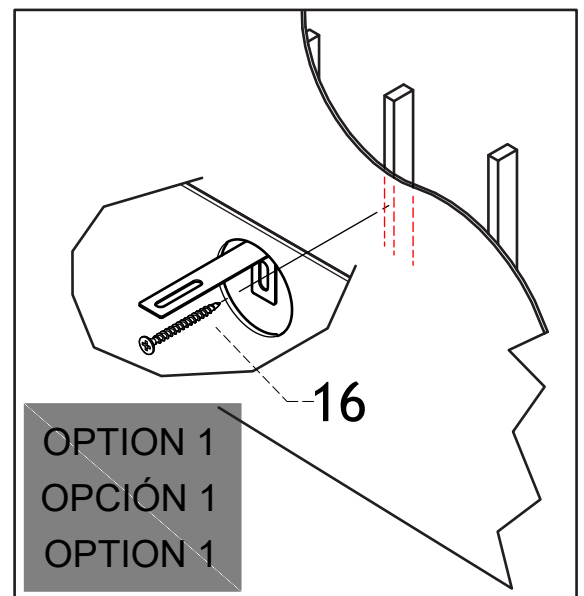
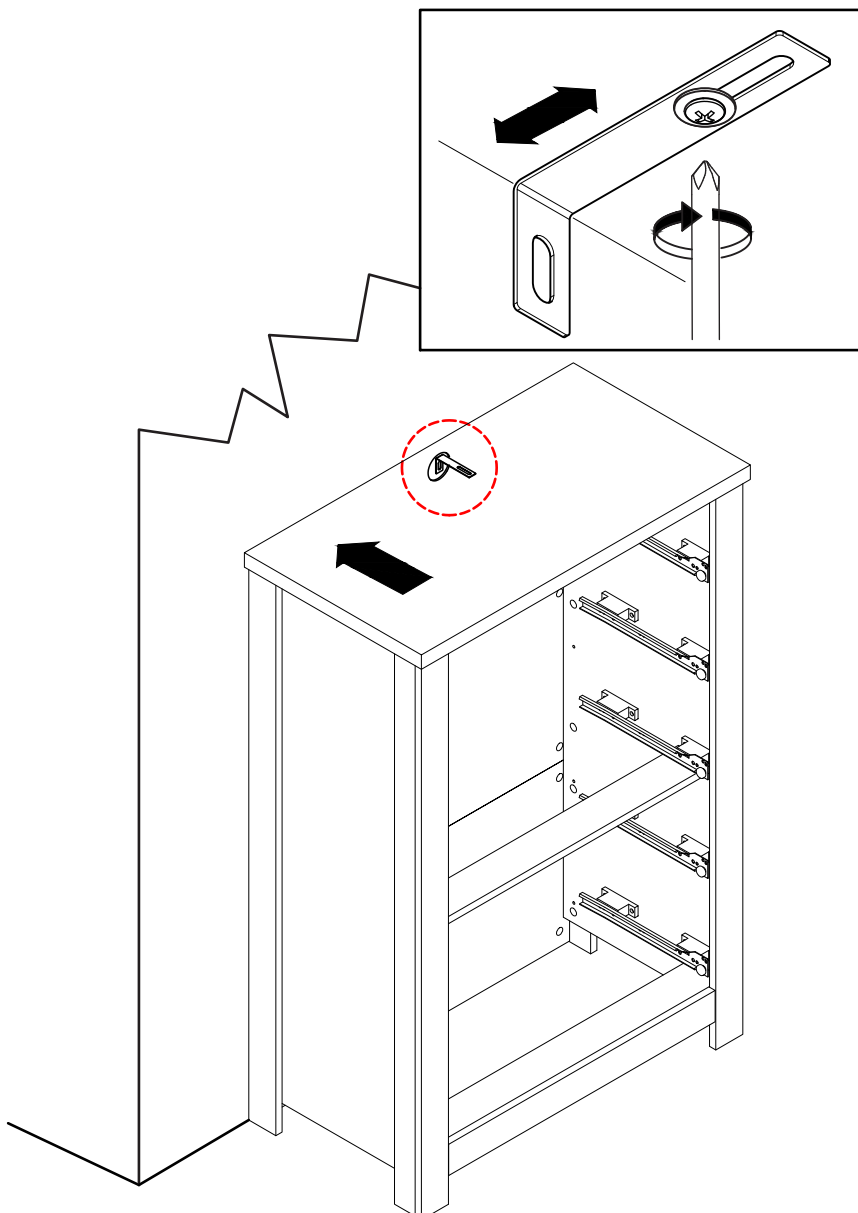

### **OPTION 1: Attachment into a wall stud (preferred method)**

Using a stud finder, locate a stud in the wall. Place your unit against the wall, with the safety bracket aligned in this location. To make driving the screw easier, you can drill a 3mm diameter pilot hole through the safety bracket into the stud. Drive the screw through the safety bracket into the wall stud. Tighten the screw that was not fully tightened in step 9.

### **OPTION 2: Attachment into masonry**

Locate your unit where desired against a wall and mark the wall through the safety bracket, then move your unit aside. Drill a 6mm diameter hole into the wall. Tap the wall anchor into the hole until it is flush. Move your unit into location and fasten the wall bracket to the wall anchor with the screw. Tighten the screw that was not fully tightened in step 9.

### **OPCION 1: Adjunto en un perno de pared (método preferido)**

Con un buscador de pernos, localice un perno en la pared. Coloque la unidad contra la pared, con el soporte de seguridad alineado en esta ubicación. Para facilitar la conducción del tornillo, puede perforar un orificio piloto de 3 mm de diámetro a través del soporte de seguridad en el perno. Conduzca el tornillo a través del soporte de seguridad en el perno de pared. Apriete el tornillo que no estaba completamente apretado en el paso 9

### **OPCION 2: Fijación en la albañilería**

Localice su unidad donde desee contra una pared y marque la pared a través del soporte de seguridad, luego a un lado su unidad. Taladre un orificio de 6 mm de diámetro en la pared. Toque el ancla de la pared en el agujero hasta que está al ras. Mueva la unidad a la ubicación y fije el soporte de pared al anclaje de pared con el tornillo. Apriete el tornillo que no estaba completamente apretado en el paso 9.

### **OPTION 1 : Fixation dans un goujon de mur (méthode préférée)**

À l'aide d'un stud finder, localisez un goujon dans le mur. Placez votre appareil contre le mur, avec le support de sécurité alignés à cet endroit. Pour faciliter la conduite de la vis, vous pouvez percer un trou pilote de 3 mm de diamètre à travers le support de sécurité dans le goujon. Conduisez la vis à travers le support de sécurité dans le goujon du mur. Serrez la vis qui n'a pas été entièrement serrée à l'étape 9.

### **OPTION 2 : Fixation en maçonnerie**

Localisez votre appareil lorsque vous le souhaitez contre un mur et marquez le mur à travers le support de sécurité, puis déplacez votre unité de côté. Percez un trou de 6 mm de diamètre dans le mur. Appuyez sur l'ancre murale dans le trou jusqu'à ce qu'il est flush. Déplacez votre unité dans l'emplacement et attachez le support de mur à l'ancre de mur avec la vis. Serrez la vis qui n'a pas été entièrement serrée à l'étape 9.

## STEP 33

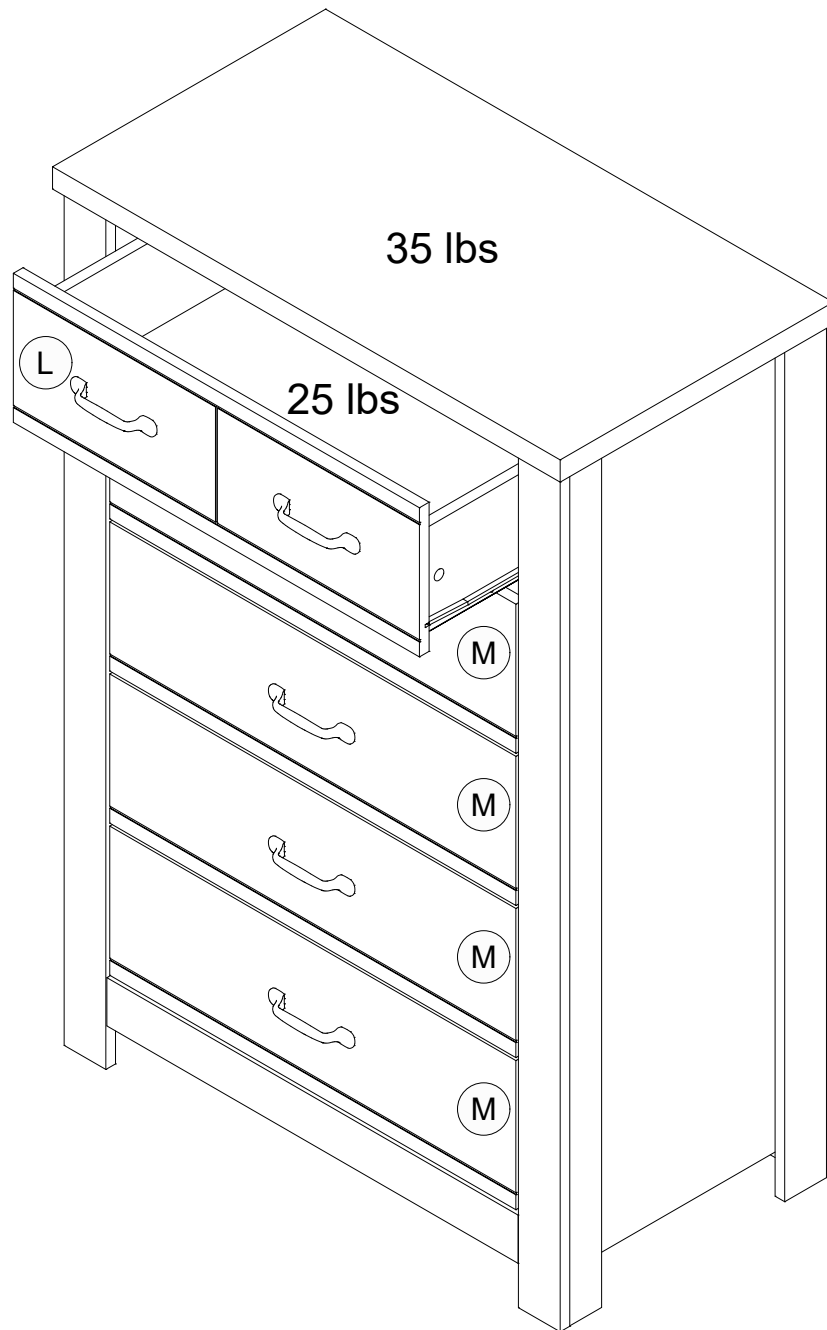

This product is designed to withstand the weight vindicated on the plan. We are not responsible for the breakage of parts or any injury caused by failure to comply with this recommendation.

Este producto está diseñado para soportar el peso indicado en el plan. No somos responsables de la rotura de piezas o cualquier lesión causada por el incumplimiento de esta recomendación.

Ce produit est conçu pour résister au poids indiqué sur le plan. Nous ne sommes pas responsables de la rupture de pièces ou de toute blessure causée par le non-respect de cette recommandation.

