

98876

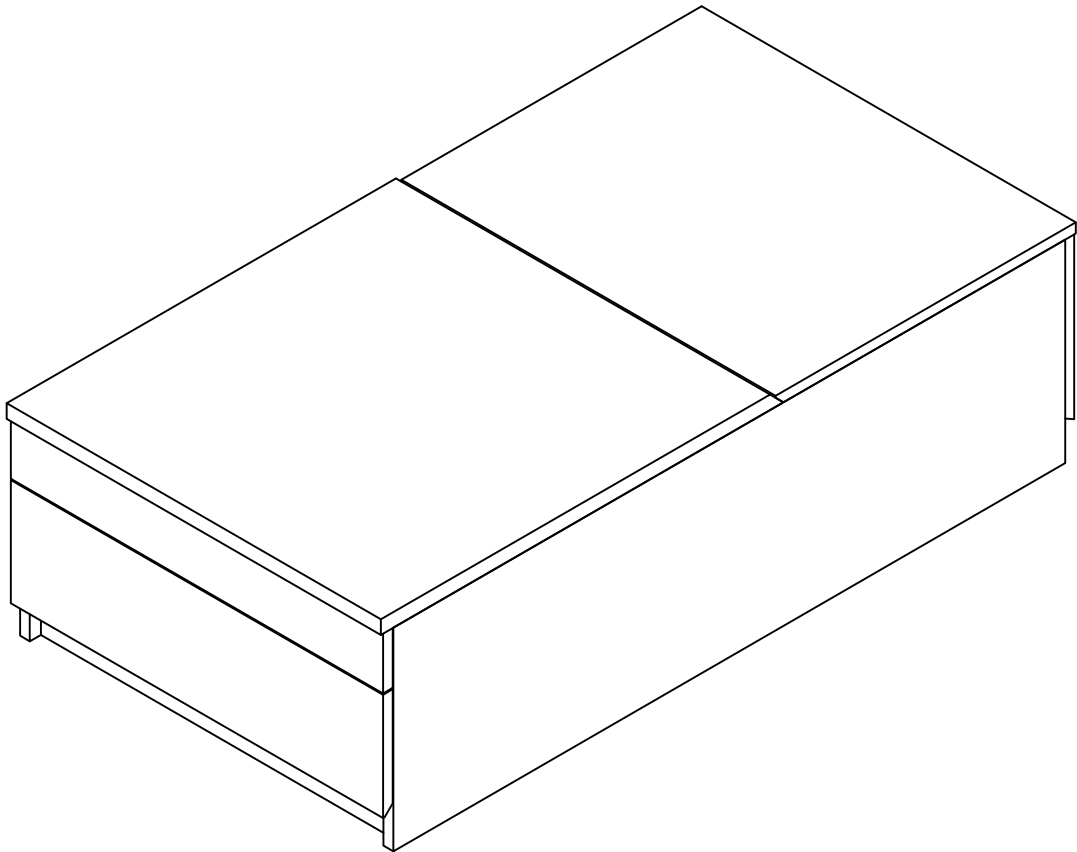

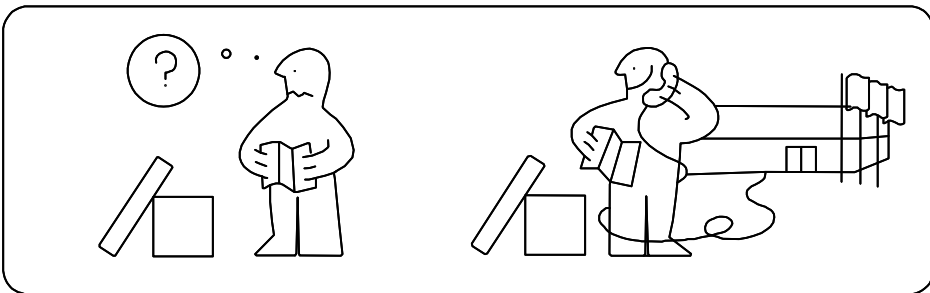

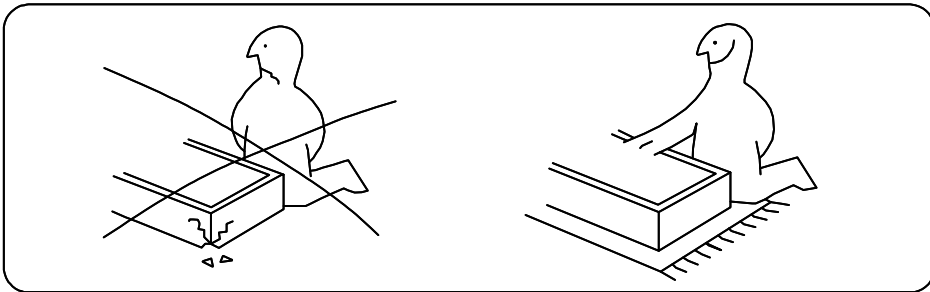
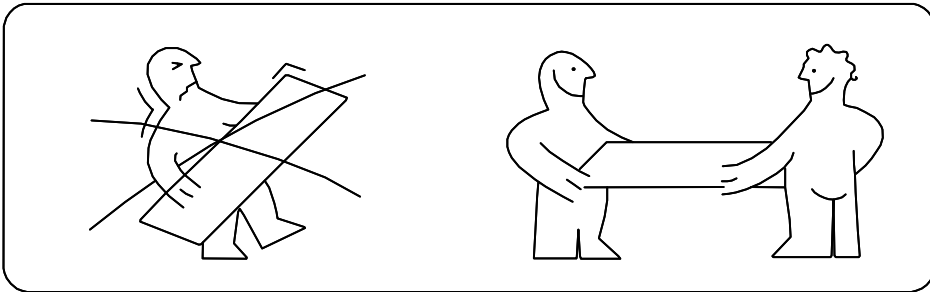
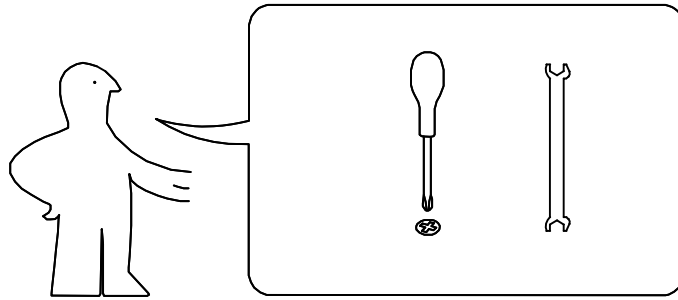
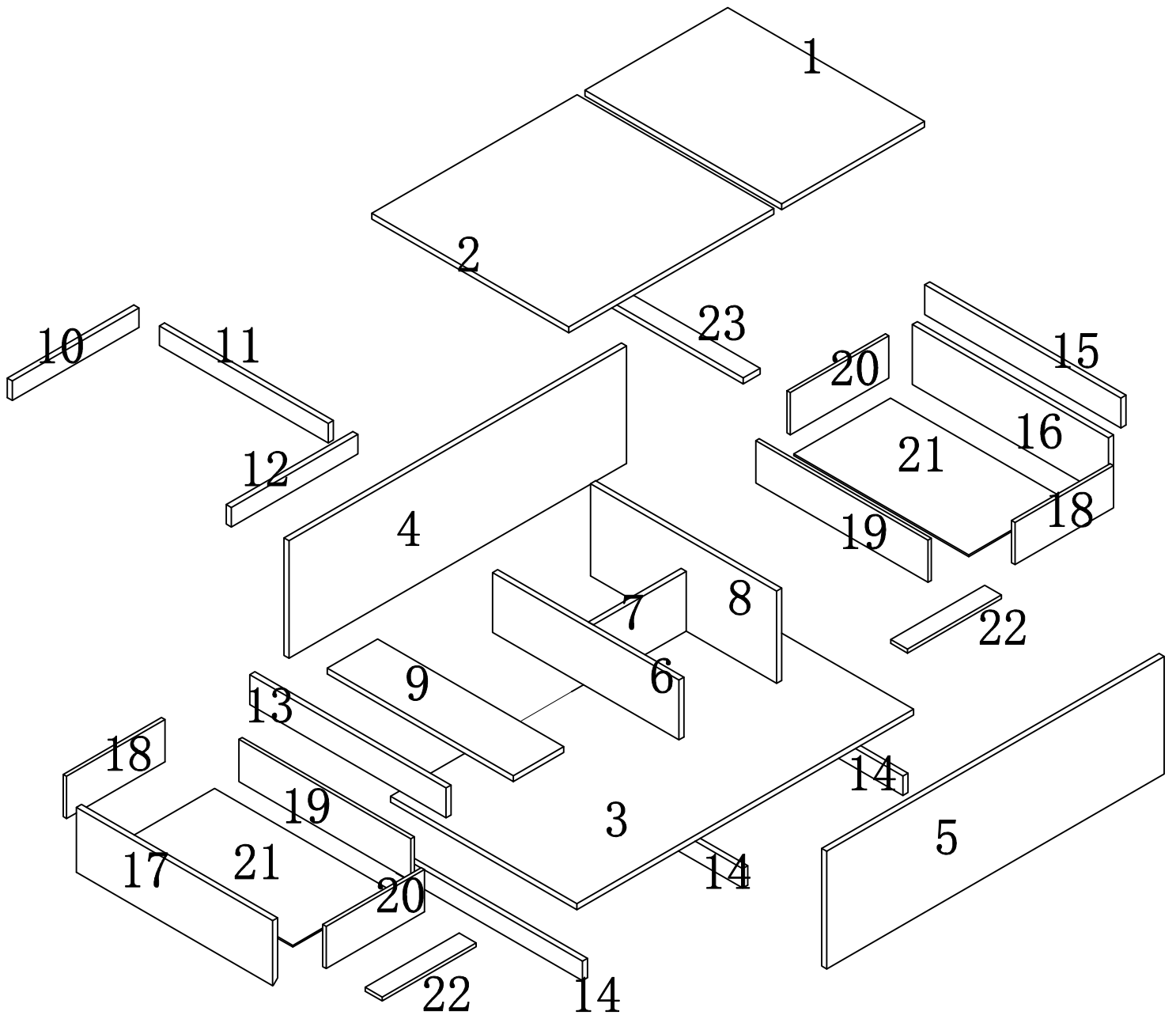

COFFEE TABLE





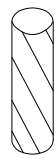
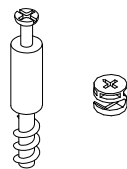

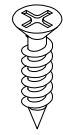

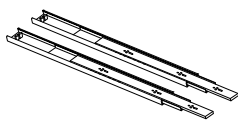
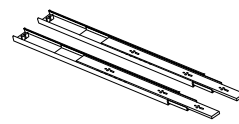
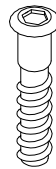
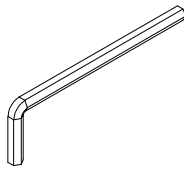
| NO. | SIZE | QTY |
|-------|-------------|-----|
| 1 | 508*700*18 | 1 |
| 2 | 730*700*18 | 1 |
| 3 | 1198*662*18 | 1 |
| 4/5 | 1200*362*18 | 2 |
| 6 | 662*184*18 | 1 |
| 7 | 330*184*18 | 1 |
| 8 | 662*284*18 | 1 |
| 9 | 662*100*18 | 1 |
| 10/12 | 450*60*18 | 2 |
| 11 | 600*60*18 | 1 |
| 13/15 | 698*92*18 | 2 |
| 14 | 662*60*18 | 3 |
| 16/17 | 696*200*18 | 2 |
| 18/20 | 350*130*12 | 4 |
| 19 | 612*130*12 | 2 |
| 21 | 622*344*5 | 2 |
| 22 | 334*60*12 | 2 |
| 23 | 658*60*18 | 1 |

| | | | | | | | | |
|---|--------|-------|---|-----------------------|-------|---|--------------------|-------|
|  | | |  | | |  | | |
| A | L=42mm | 57pcs | B | $\phi 15 \times 13.5$ | 57pcs | C | $\phi 8 \times 30$ | 40pcs |
|  | | |  | | |  | | |
| D | / | 10PCS | E | M4*30 | 12PCS | F | M3*12 | 27pcs |
|  | | |  | | |  | | |
| G | M6*32 | 2pcs | H | 300mm | 2pa | I | 350mm | 1pa |
|  | | |  | | | | | |
| J | M7*38 | 4pcs | K | M4 | 1pcs | | | |

step 1:

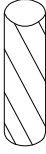
| | | | | | | | | |
|---|--------|------|---|-----------------------|------|--|--------------------|------|
|  | | |  | | |  | | |
| A | L=42mm | 6pcs | B | $\phi 15 \times 13.5$ | 6pcs | C | $\phi 8 \times 30$ | 6pcs |

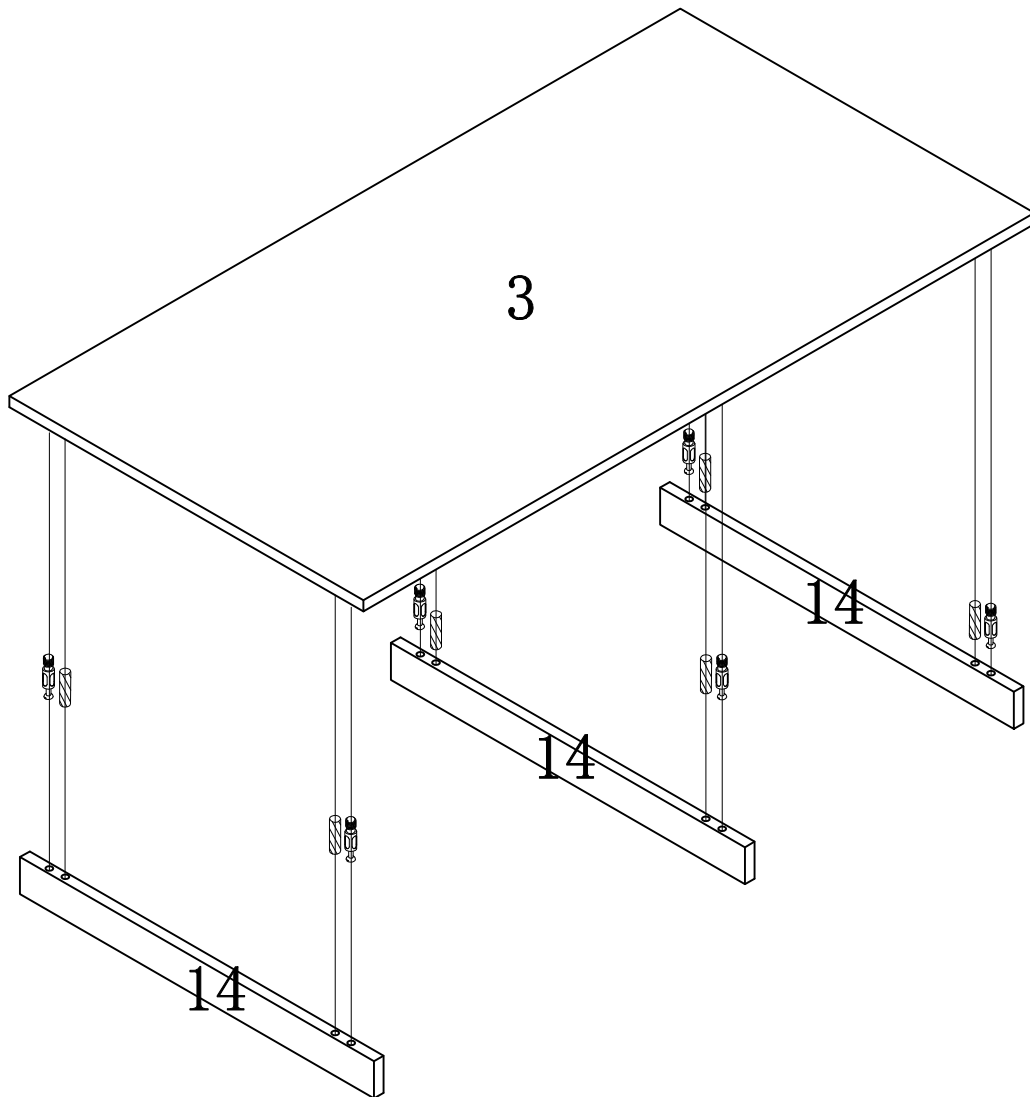

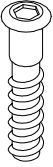
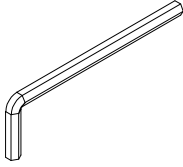

step 2:

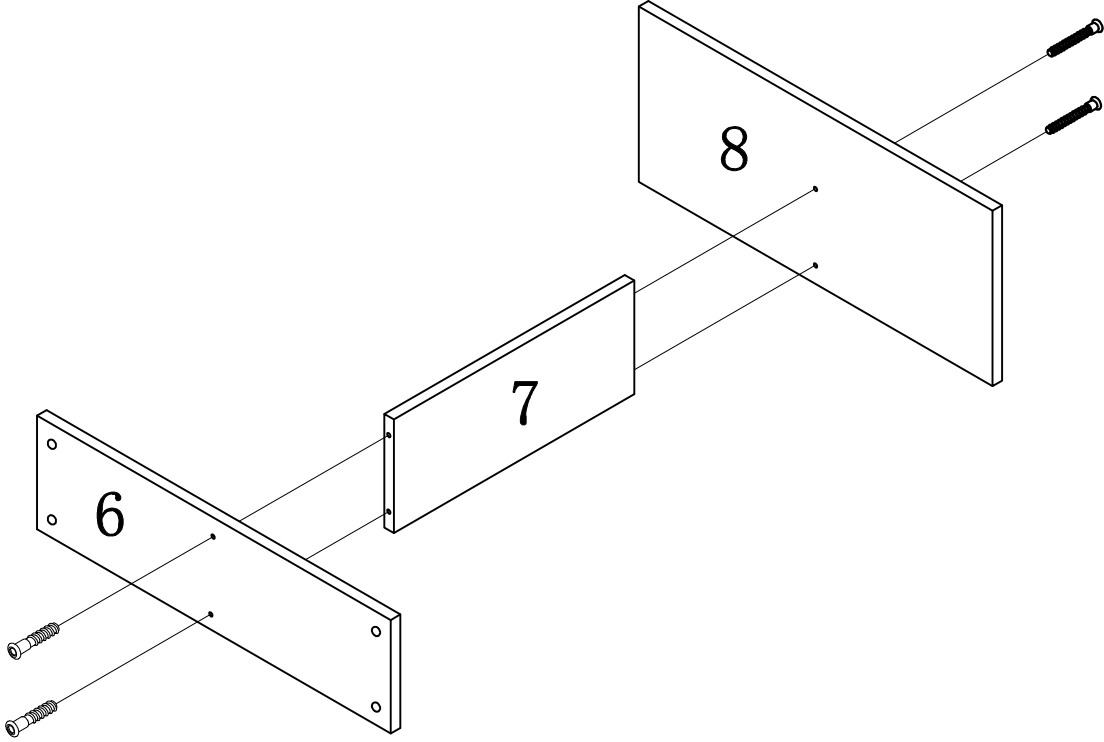
| | | | | | |
|---|-------|------|---|----|------|
|  | | |  | | |
| J | M7*38 | 4pcs | K | M4 | 1pcs |

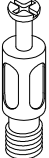

step 3:

| | | | | | | | | |
|---|--------|------|---|----------------|------|--|-------------|------|
|  | | |  | | |  | | |
| A | L=42mm | 4pcs | B | $\phi 15*13.5$ | 4pcs | C | $\phi 8*30$ | 6pcs |

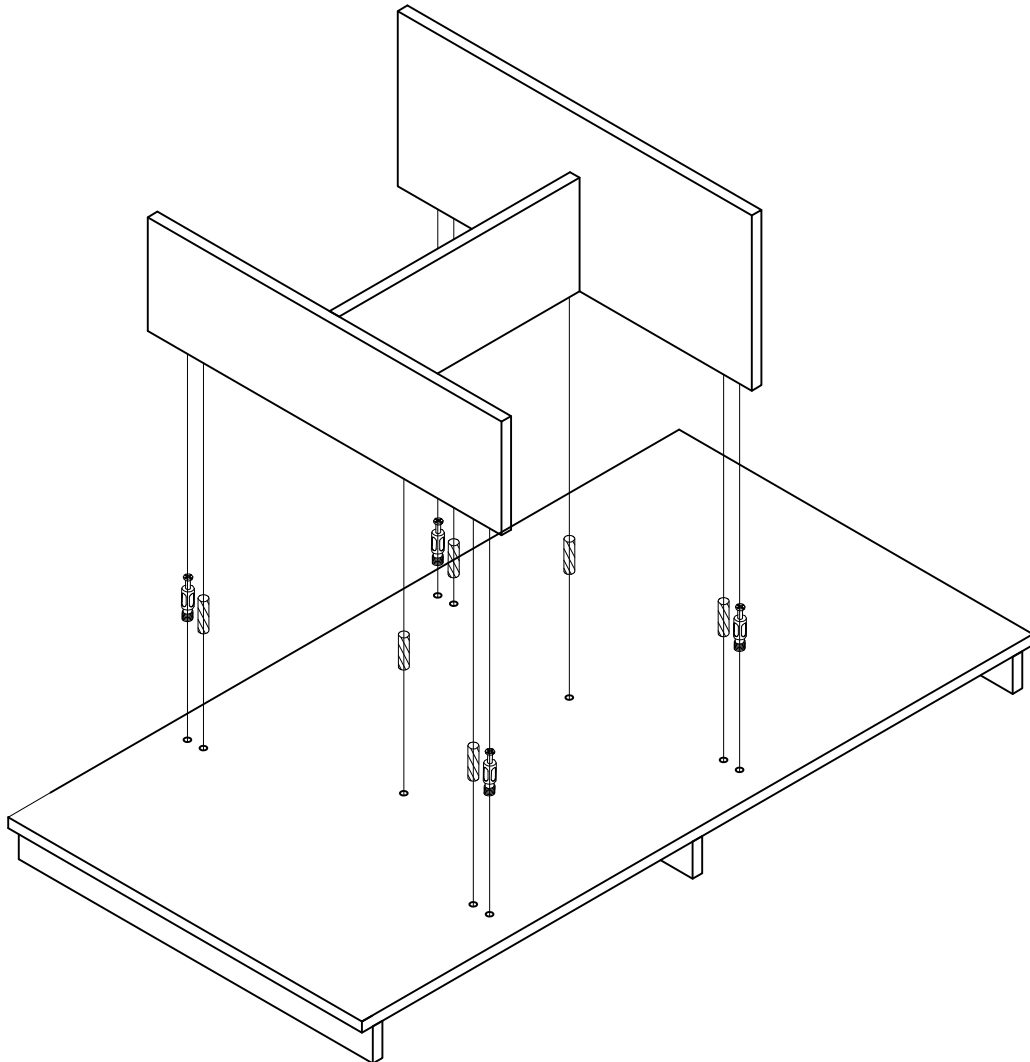

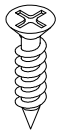
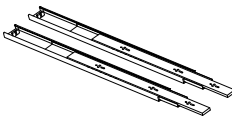
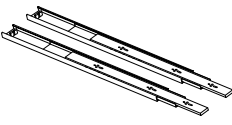

step 4:

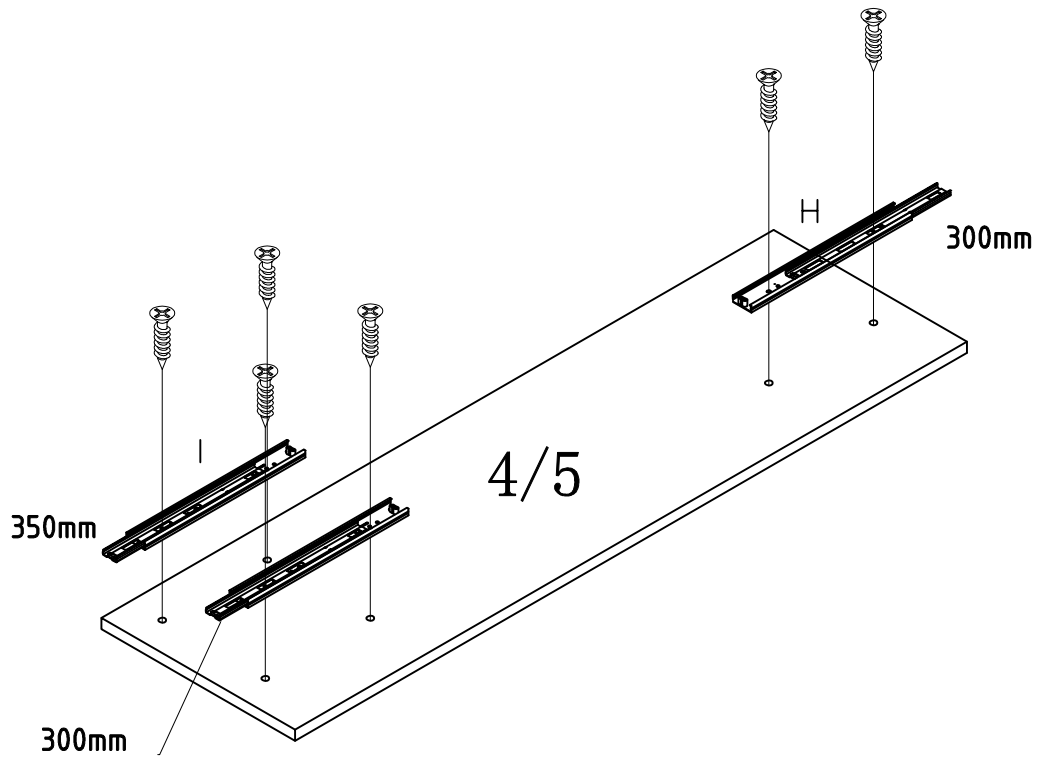
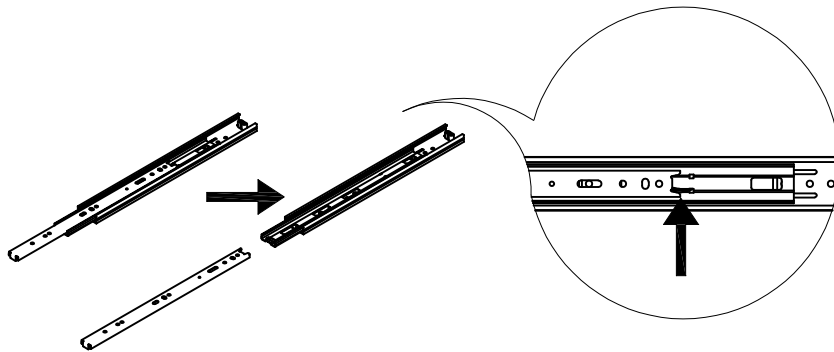
| | | | | | | | | |
|---|-------|------|---|-------|-----|--|-------|-----|
|  | | |  | | |  | | |
| F | M3*12 | 8pcs | H | 300mm | 1pa | I | 350mm | 1pa |



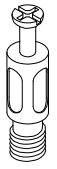

step 5:

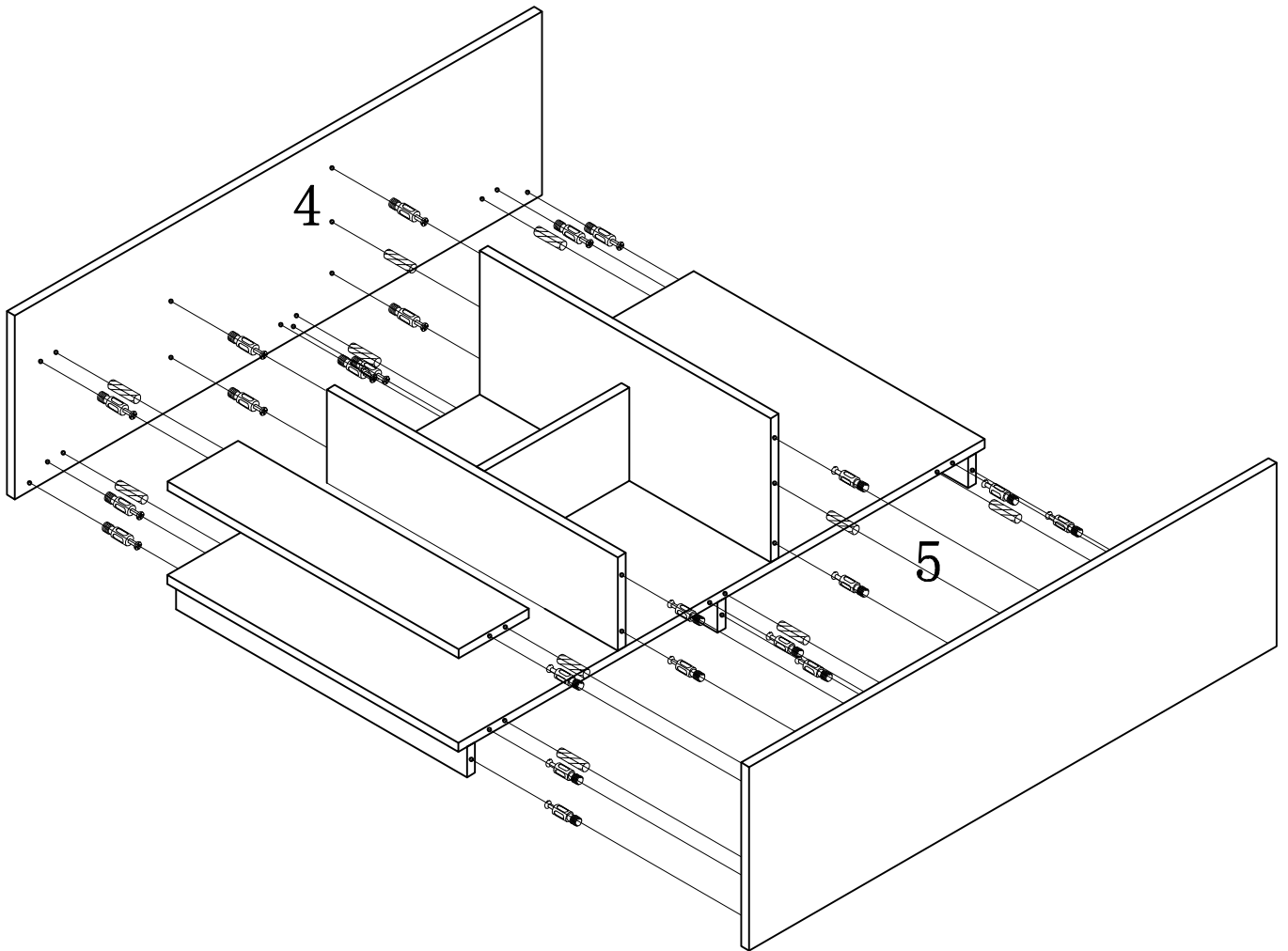
| | | | | | | | | |
|---|--------|-------|---|----------------|-------|--|-------------|-------|
|  | | |  | | |  | | |
| A | L=42mm | 22pcs | B | $\phi 15*13.5$ | 22pcs | C | $\phi 8*30$ | 10pcs |



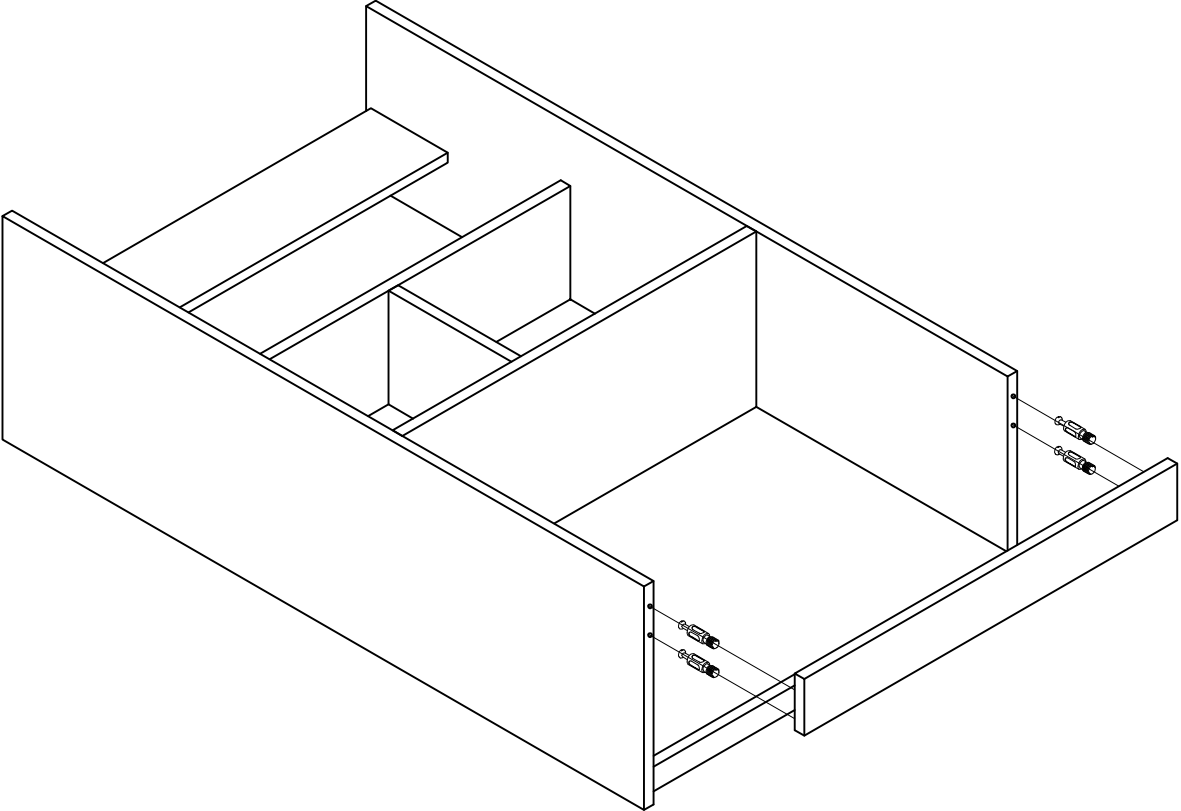

step 6:

| | | | | | |
|---|--------|------|---|----------|------|
|  | | |  | | |
| A | L=42mm | 4pcs | B | Ø15*13.5 | 4pcs |

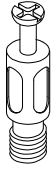

step 7:

| | | | | | | | | |
|---|--------|------|---|-----------------------|------|--|--------------------|------|
|  | | |  | | |  | | |
| A | L=42mm | 8pcs | B | $\phi 15 \times 13.5$ | 8pcs | C | $\phi 8 \times 30$ | 8pcs |

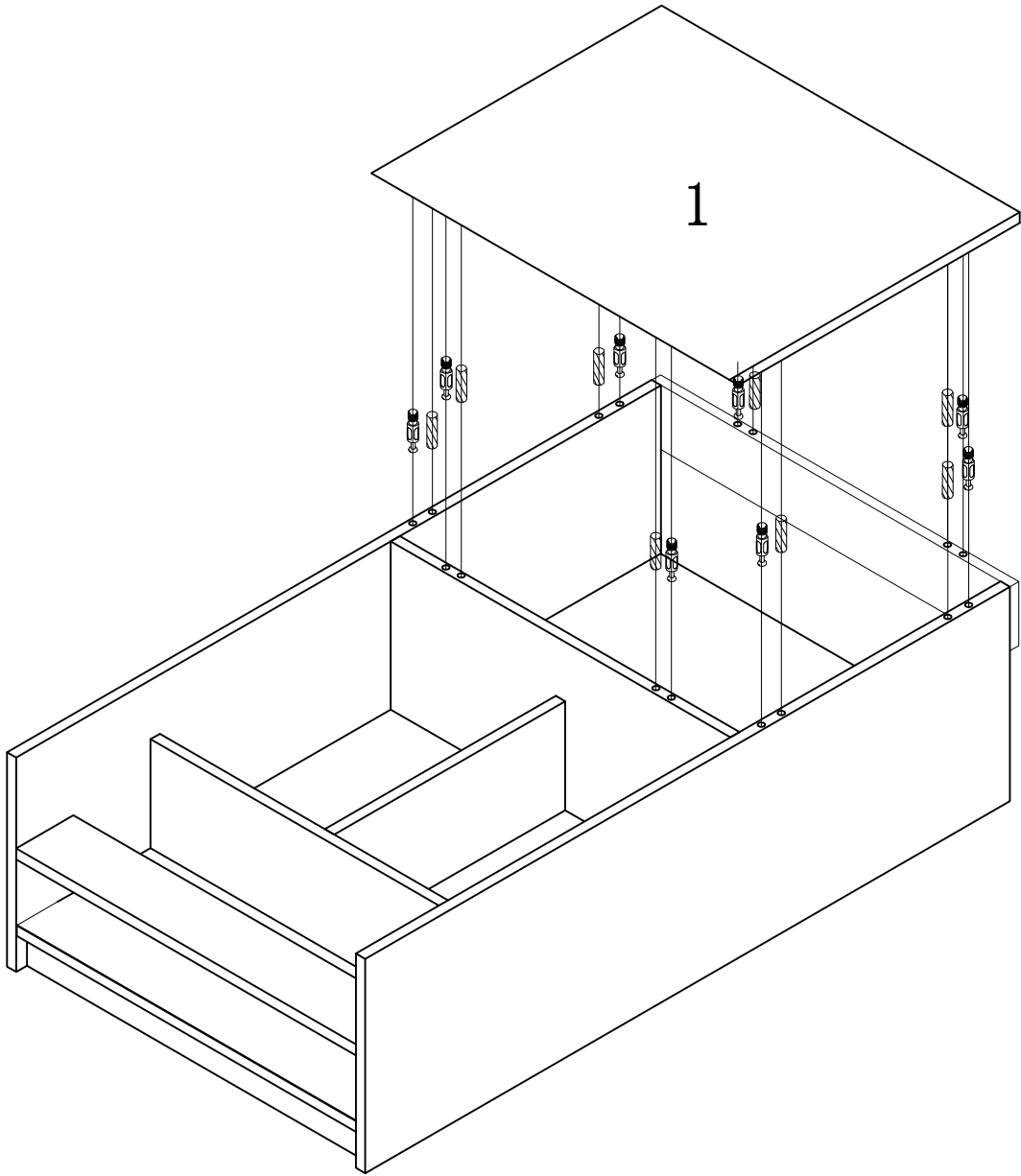

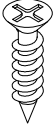
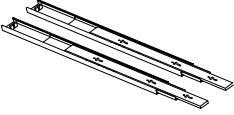

step 8:

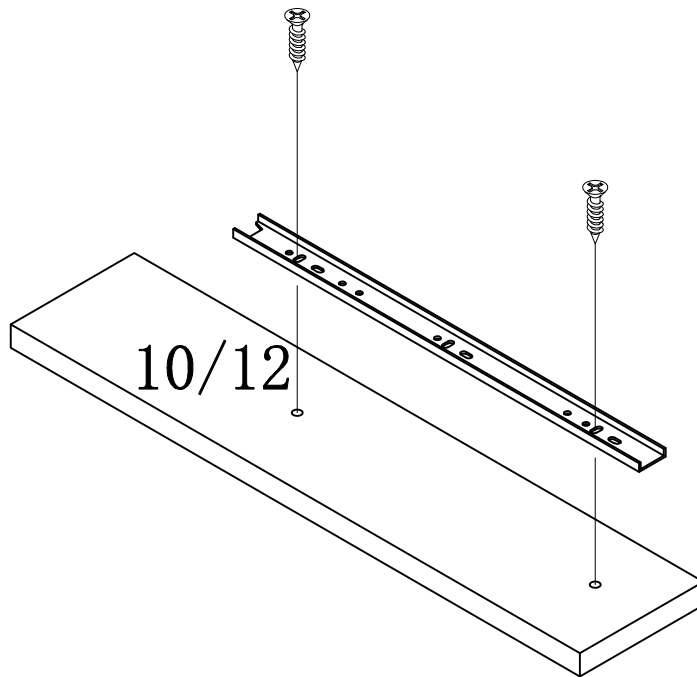
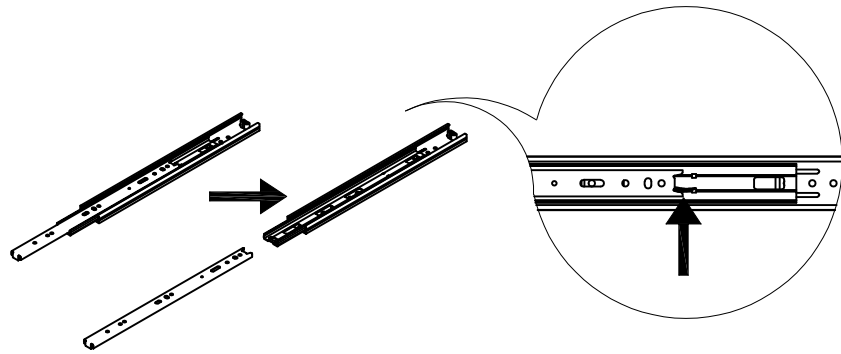
| | | | | | |
|---|-------|---|--|-------|-----|
|  | |  | | | |
| F | M3*12 | 4pcs | | 350mm | 1pa |



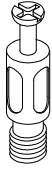

step 9:

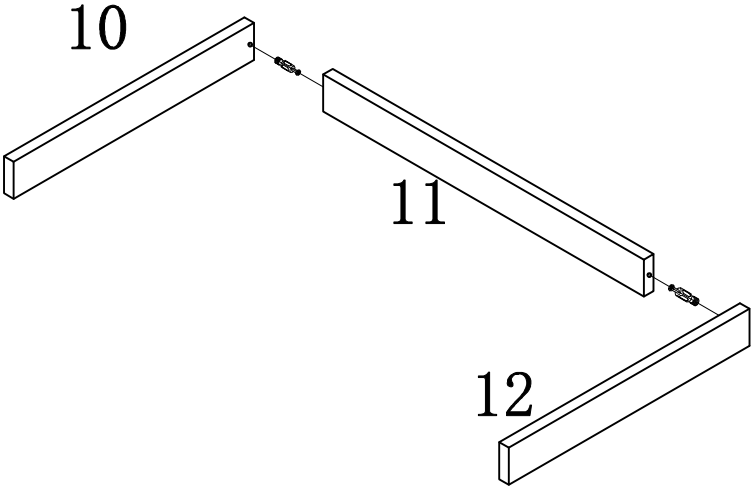
| | | | | | |
|---|--------|------|---|----------------|------|
|  | | |  | | |
| A | L=42mm | 2pcs | B | $\phi 15*13.5$ | 2pcs |



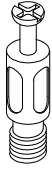

step 10:

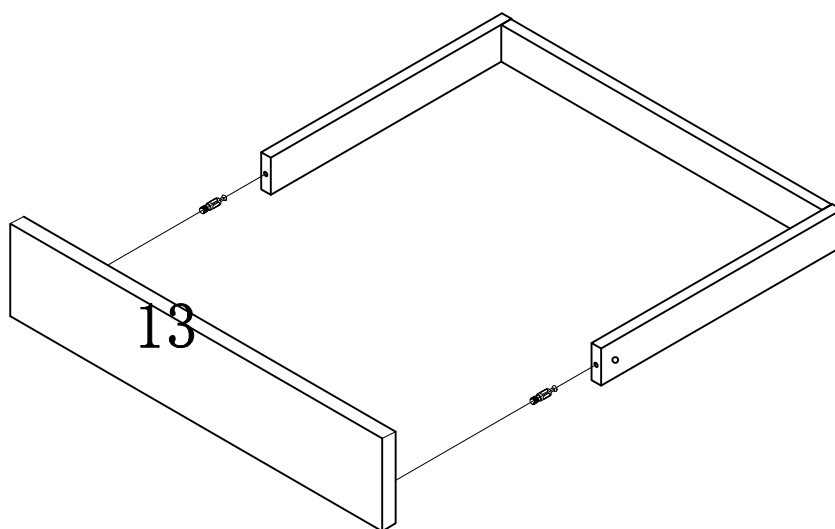
| | | | | | |
|---|--------|------|---|----------------|------|
|  | | |  | | |
| A | L=42mm | 2pcs | B | $\phi 15*13.5$ | 2pcs |

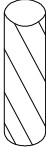

step 11:

| | | | | | | | | |
|---|--------|------|---|-----------------------|------|--|--------------------|------|
|  | | |  | | |  | | |
| A | L=42mm | 9pcs | B | $\phi 15 \times 13.5$ | 9pcs | C | $\phi 8 \times 30$ | 8pcs |

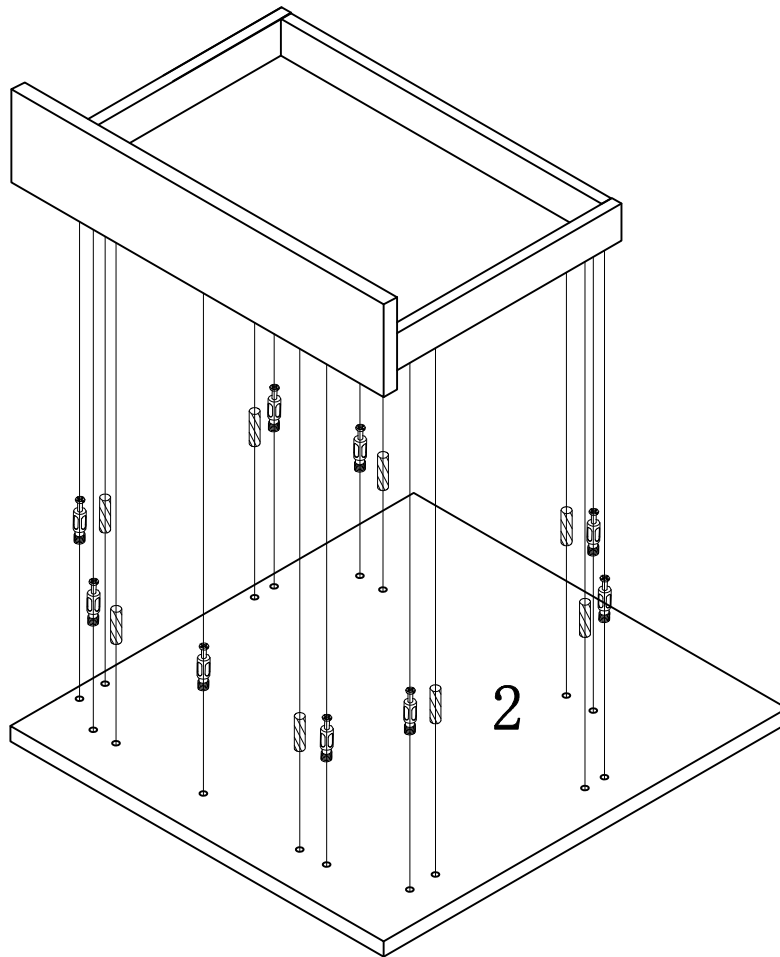

step 12:

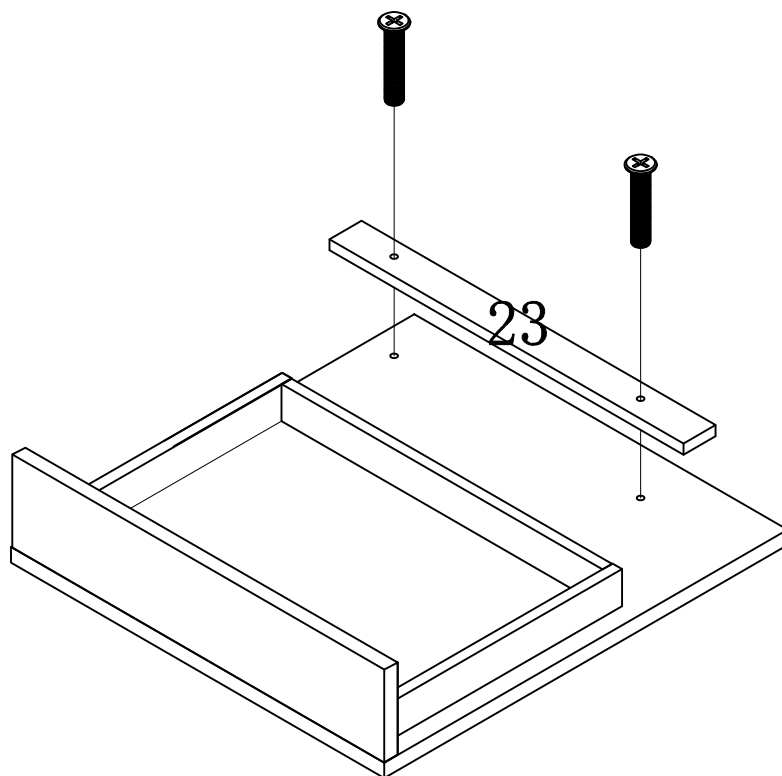
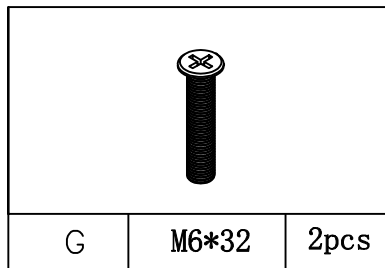

step 13:

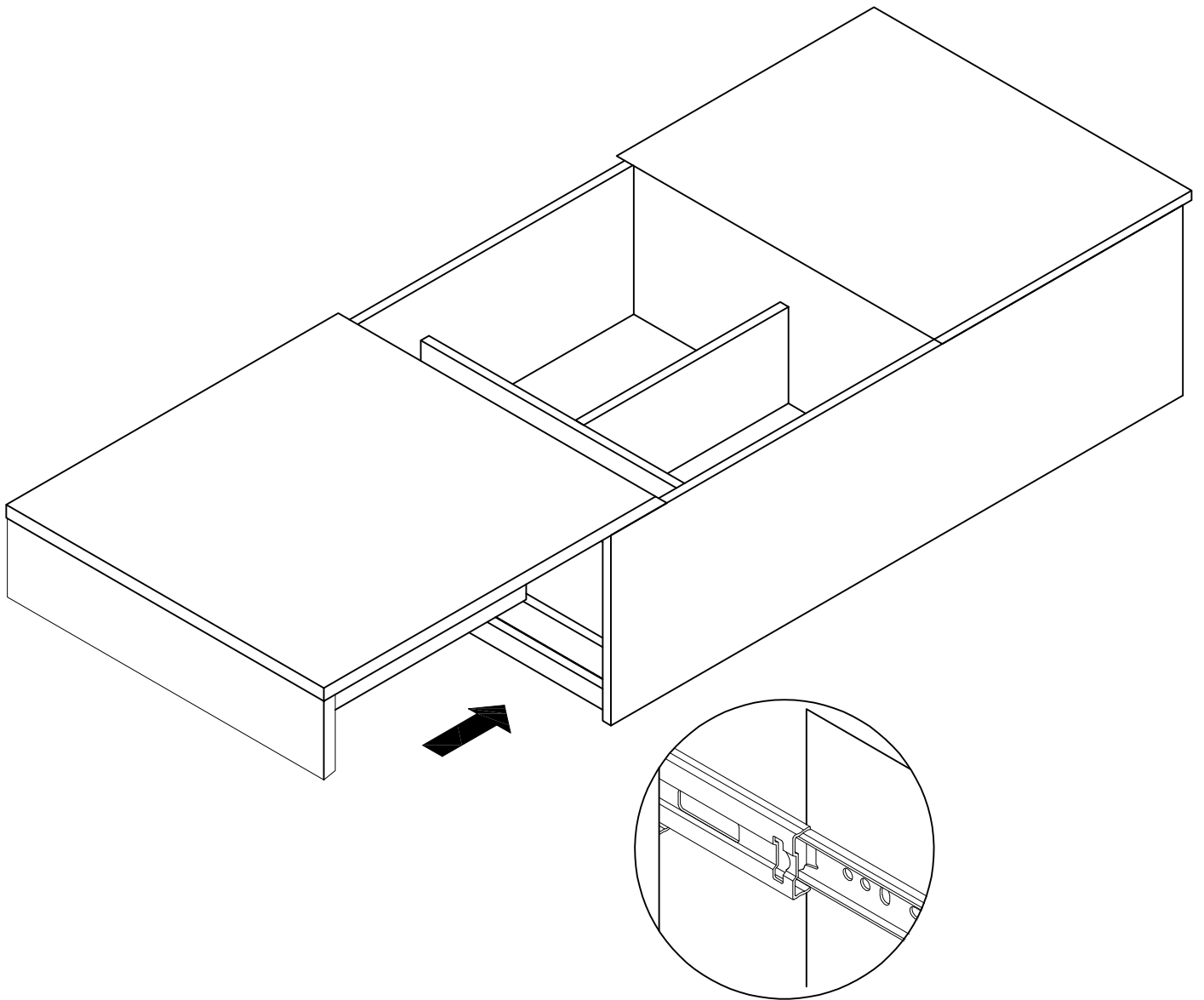

step 14:

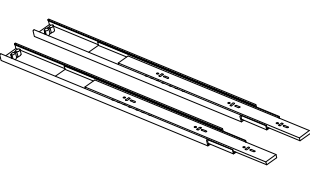
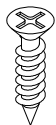
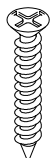
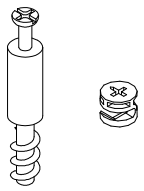
| | | | | | | | | | | | |
|---|-------|-----|---|-------|------|--|-------|-------|---|--------|--------|
|  | | |  | | |  | | |  | | |
| M | 300mm | 1pa | F | M3*12 | 8PCS | E | M4*30 | 12PCS | D | L=20mm | 10sets |

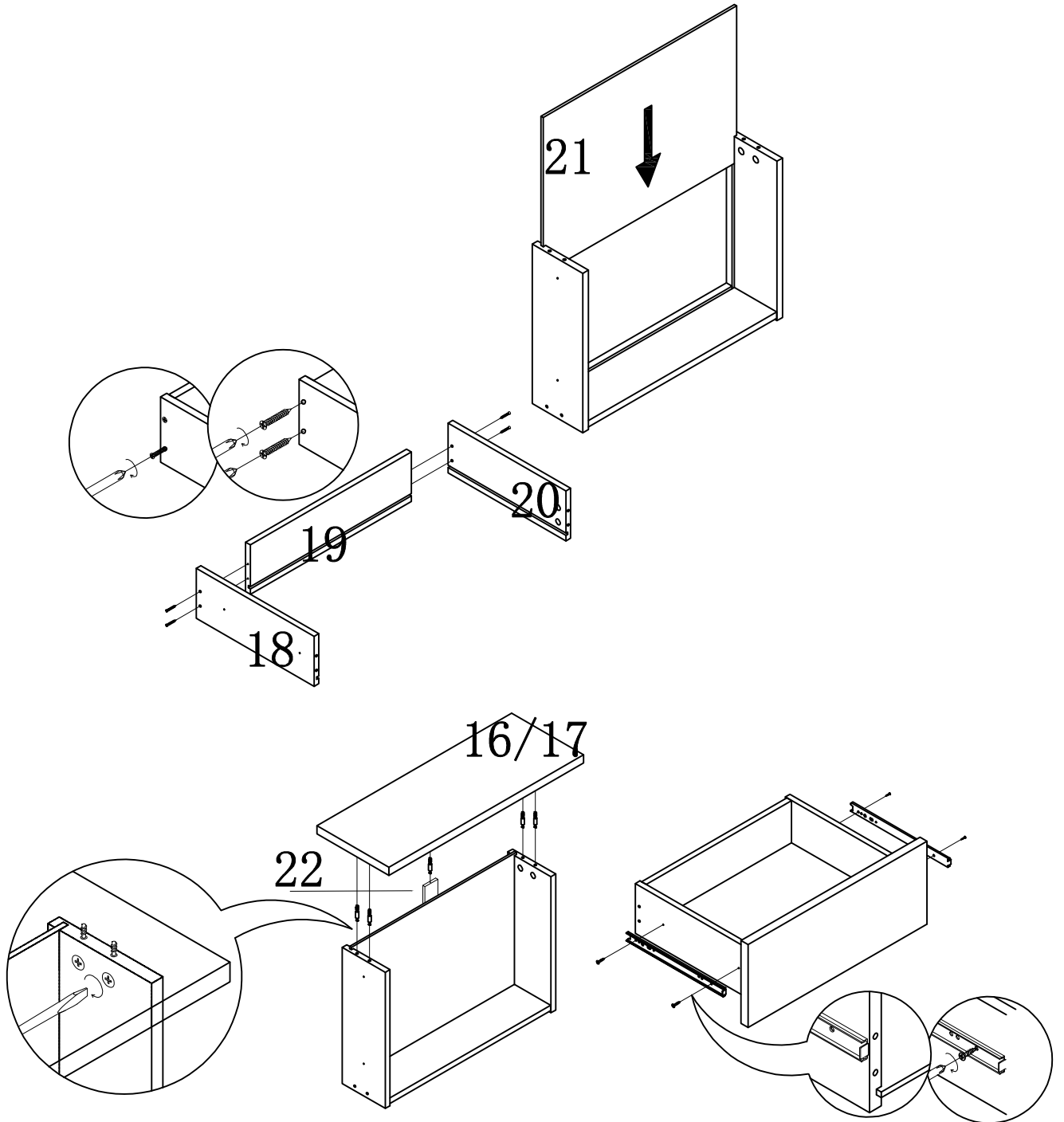

step 15:

