





ASSEMBLY INSTRUCTION

ITEM:98012&98014&98016

HARDWARE LIST:

| | | | | |
|---|---|-------------------|----------|--------|
| A |  | BOLT | 1/4" *1" | 16 PCS |
| B |  | ALLEN WRENCH | 4MM | 1 PC |
| C |  | METAL PLATE | | 4 PCS |
| D |  | CROSS METAL PLATE | | 1 PC |

STEP: 1

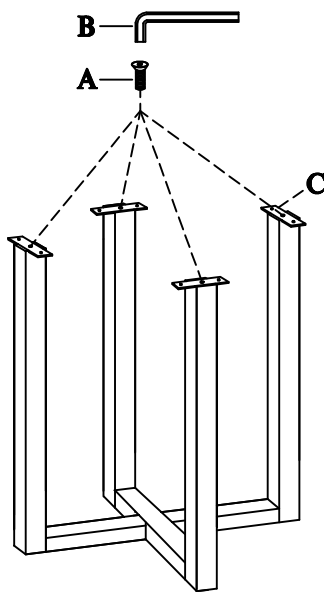

STEP: 2

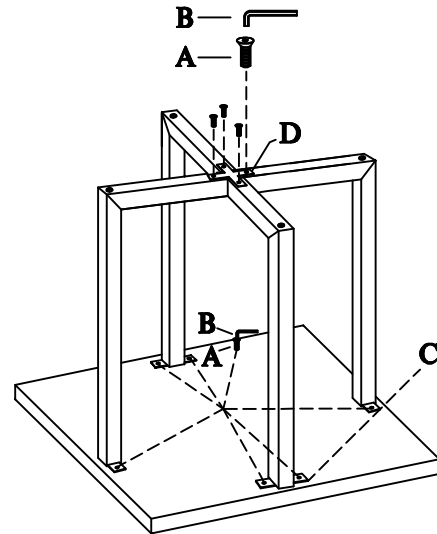

STEP: 3

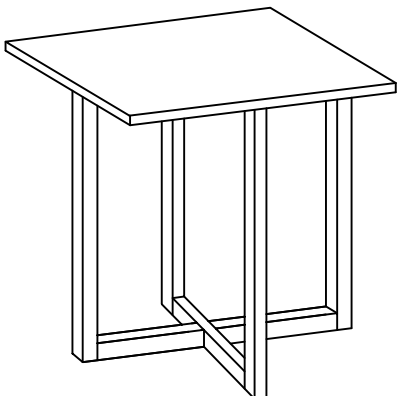

Caution:Please do not tighten all bolts until the end table is completely assembled!

MADE IN VIETNAM