

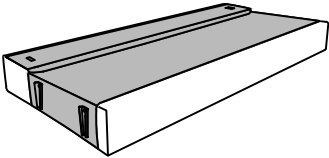

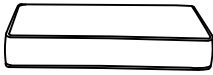

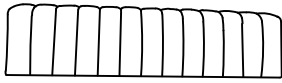
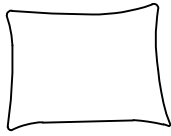
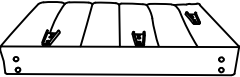
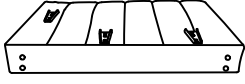
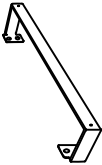

Assembly Instruction

PARTS LIST

<p>Ax1</p>  <p>seat</p>	<p>Bx2</p>  <p>seat cushion</p>	<p>Cx1</p>  <p>in other carton back frame</p>	<p>Dx2</p>  <p>pillow</p>				
<p>Ex1</p>  <p>in other carton left Arm</p>	<p>Fx1</p>  <p>in other carton right Arm</p>	<p>Gx2</p>  <p>Length 81cm Long metal foot</p>	<p>Hx2</p>  <p>Plug in connector</p>	<p>Ix8</p>  <p>25mm screw</p>	<p>Jx1</p>  <p>Allen Key</p>	<p>Kx1</p>  <p>13cm Middle foot</p>	<p>Lx1</p>  <p>washer</p>

① parts inside open here

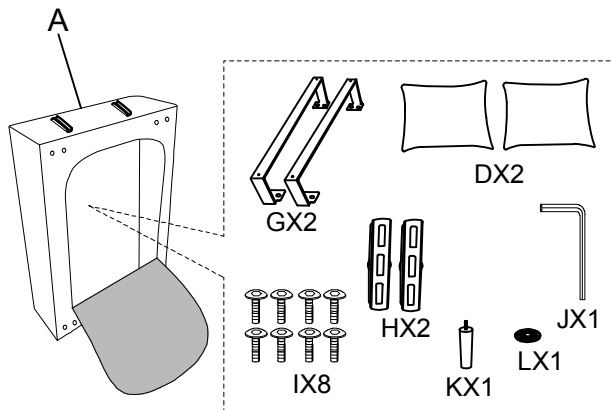

② in other carton

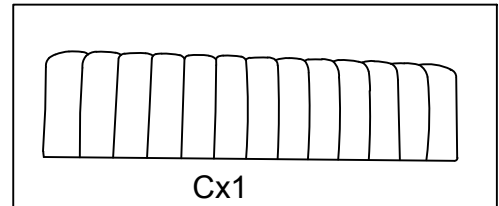

③ in other carton

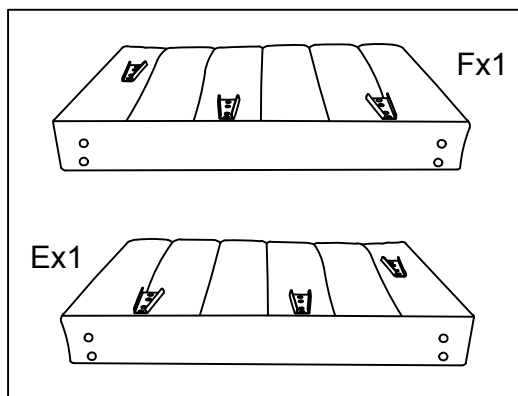

Please note : if you want left sofa ,you can choose E(left arm),if you want right sofa, you can choose F(right arm).

Step 1

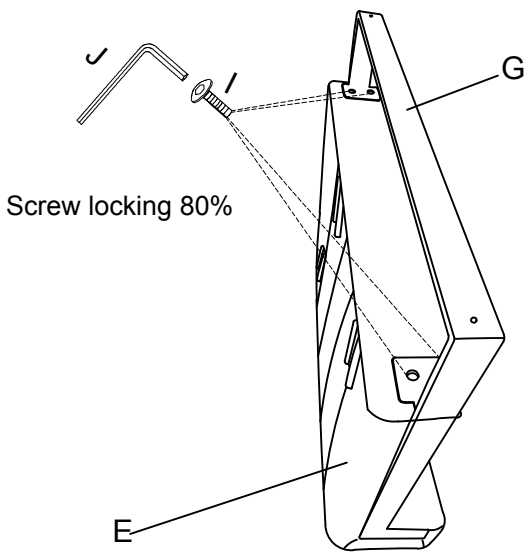

Screw locking 80%

Step 1

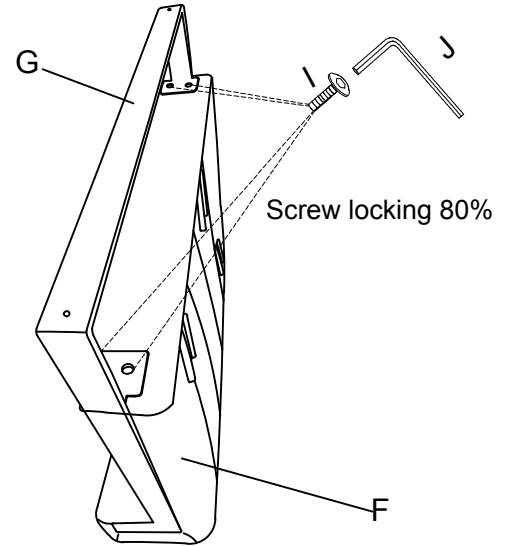

Screw locking 80%

Step 2

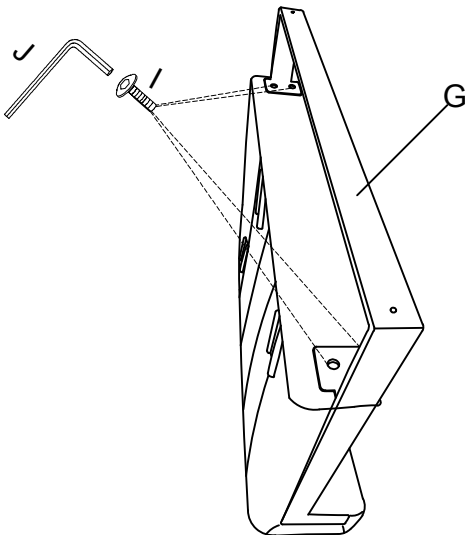

After the upper and lower feet are aligned, the screws are locked 100%

Step 2

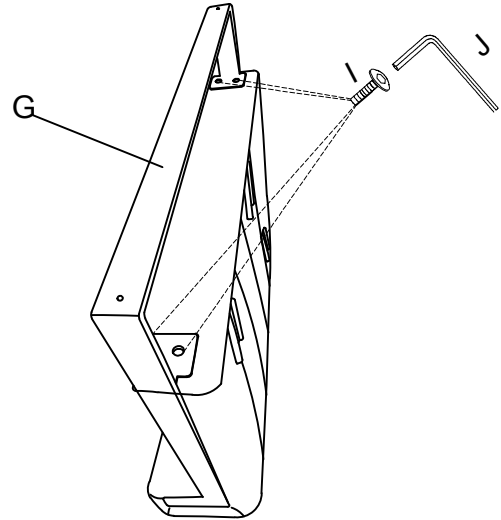

After the upper and lower feet are aligned, the screws are locked 100%

Step 3

Left sofa

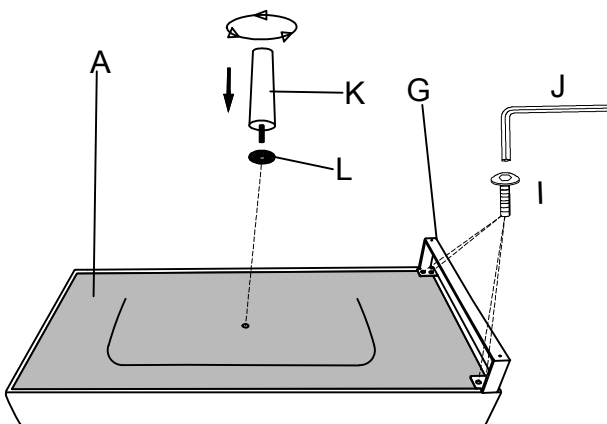

If one foot are on this side, the armrest with foot are on the other side.

Step 3

Right sofa

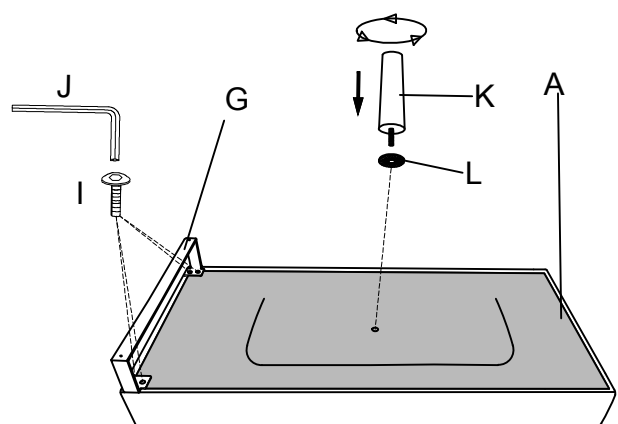

If one foot are on this side, the armrest with foot are on the other side.

Step 4

Left sofa

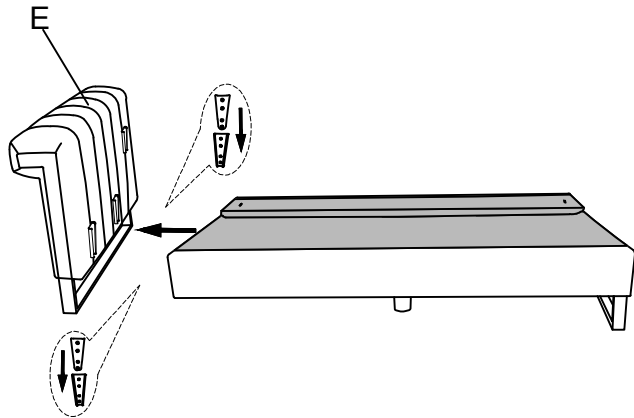

Step 4

Right sofa

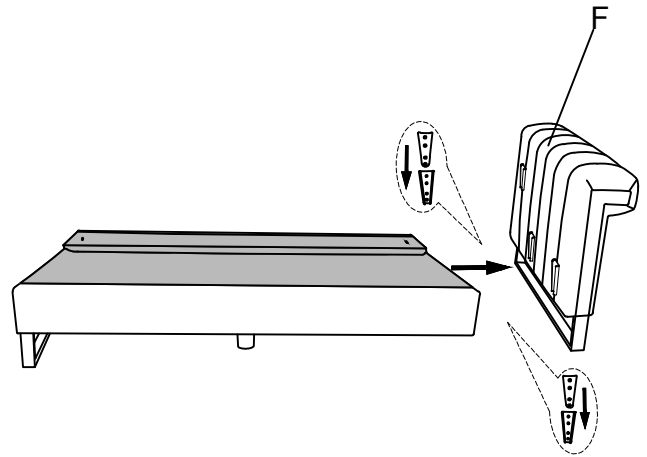

Step 5

Left sofa

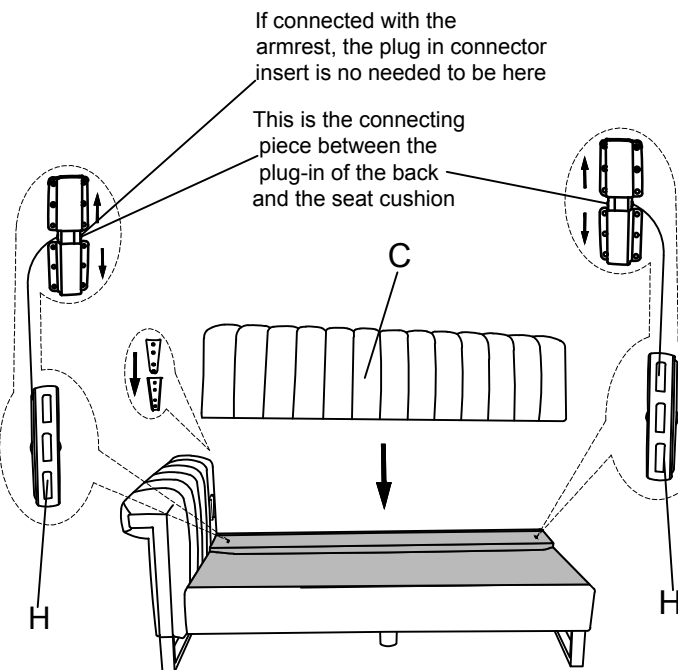

Step 5

Right sofa

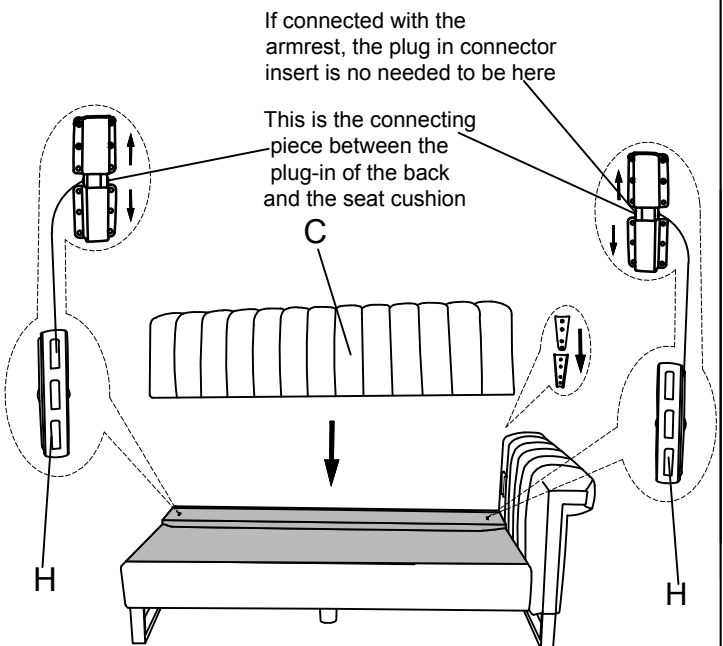

Step 6

Left sofa

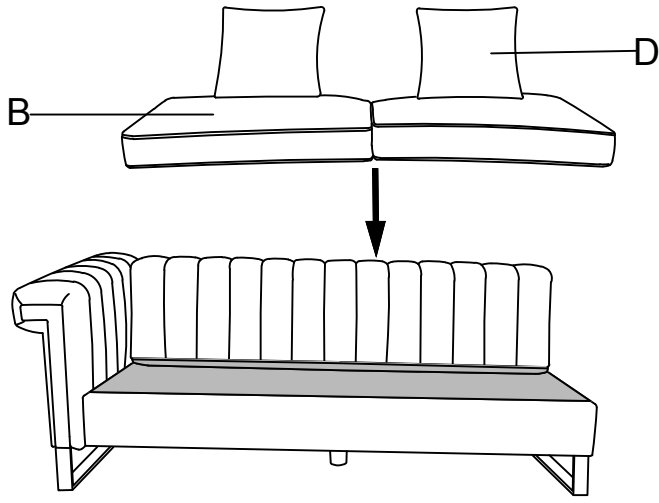

Step 6

Right sofa

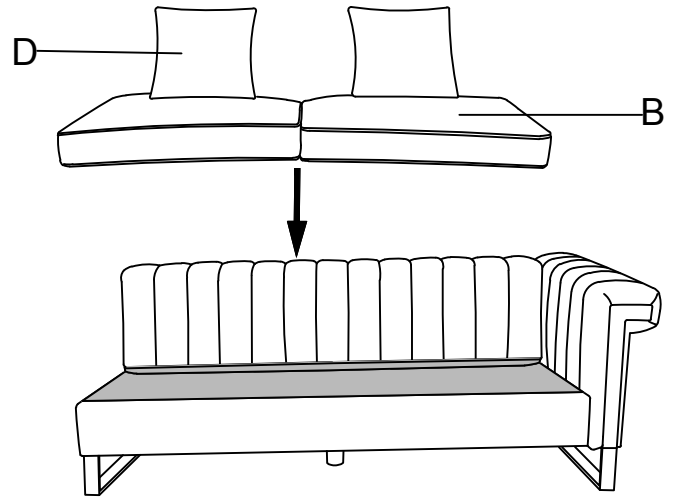

Step 7

Left sofa

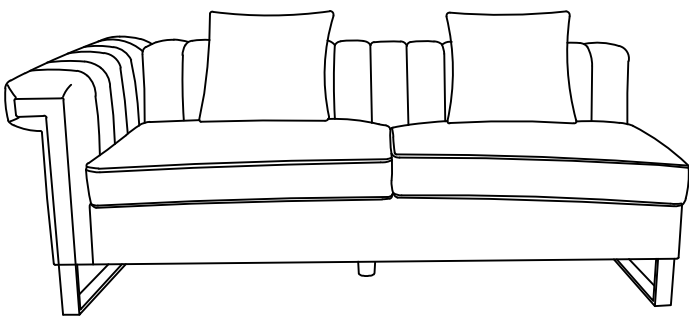

Step 7

Right sofa

