

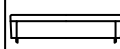









Assembly Instruction

Item No: 89732-S

| ASSEMBLY PARTS DESC. | | | Chair | ASSEMBLY PARTS DESC. | | | Chair |
|----------------------|-----------------------------------------------------------------------------------|-------------------|-------|----------------------|-------------------------------------------------------------------------------------|------------------|-------|
| A |  | Seat | 1pc | B |  | Backrest | 1pc |
| C |  | Lsf Armrest | 1pc | D |  | Rsf Armrest | 1pc |
| E |  | Lsf Back Cushion | 1pc | F |  | Rsf Back Cushion | 1pc |
| G |  | JCBC Bolt M6*20mm | 16pcs | H |  | Leg | 4pcs |
| I |  | Bolt M8*50mm | 2pcs | J |  | Allen Key | 1pc |
| K |  | Middle Leg | 1pc | L |  | Washer | 1pc |

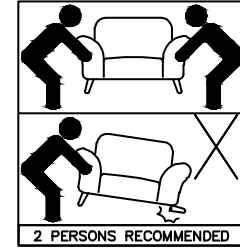

- Do not use power tools.
- Do not over-tight.
- Keep the packing materials and small parts out of reach of children.

Step1.

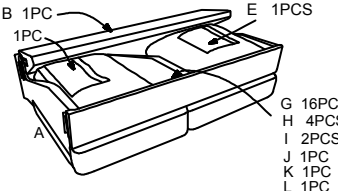

Back Cushion (E/F) 、 Backrest (B) 、 Legs(H)
And Hardware(G/I/J/K/L) Under The Seat.

G 16PCS
H 4PCS
I 2PCS
J 1PC
K 1PC
L 1PC

Step4.

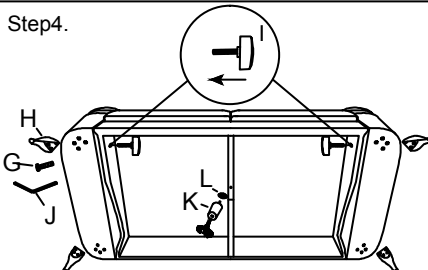

Screw down Bolt(I) as shown, Then Attach Legs(H) and Middle Leg (K) to the bottom with Bolt (G) and Allen key (J) as picture shows.

Step2.

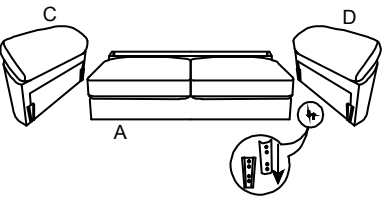

Insert seat (A) into armrests(C/D).
Press it hard to make sure it is in the lowermost position.

Step5.

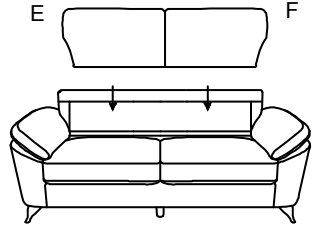

Place Back Cushions (E/F) as picture.

Step3.

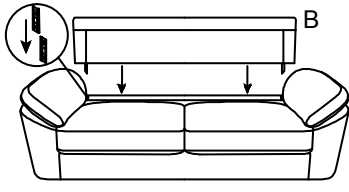

Insert backrest(B) into armrests(C/D).
Press it hard to make sure it is in the lowermost position.

Completed



FOR LEATHER AND P.U (Code"X")
Clean by lightly brushing and vacuuming only to remove dust and particles buildup. Water-based foam cleaner or solvent based cleaning agents of any kind may cause excessive shrinking, staining or distortion of the surface pile and, therefore, should not be used.

FOR FABRIC (Code"WW")

- Use water-based agents only.
- Do not use solvents.
- Gently remove stains by blotting or hang washing.
- Do not use excessive brushing or rubbing.