

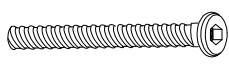



Assembly Instruction

Model: 88869

Assembly Parts Description			Chair
A		JCBC Bolt M6x30	4pcs
B		Spring Washer	4pcs
C		Flat Washer	4pcs
D		Hex Wrench M6	1pc

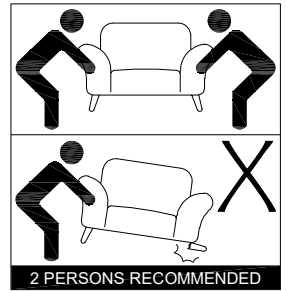

-Do not use power tools.
-Do not over-tight.
-Keep the packing materials and small parts out of reach of children.

Step 1

Align and turn clockwise the bolt(A) with spring washer(B) and flat washer(C) by hex wrench(D). Do not over-tighten.

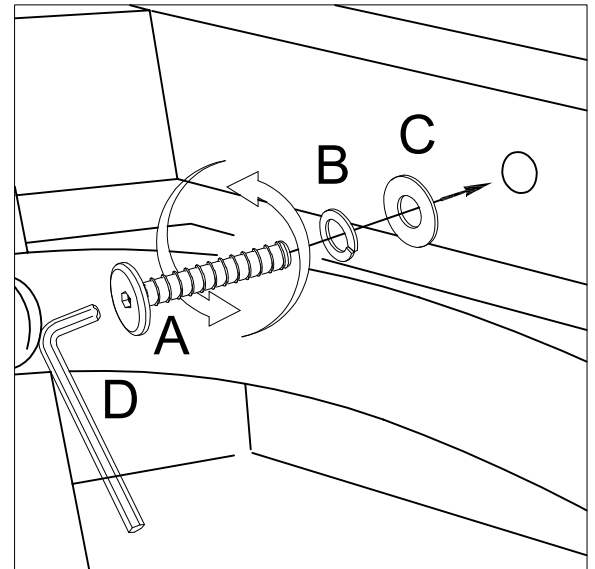
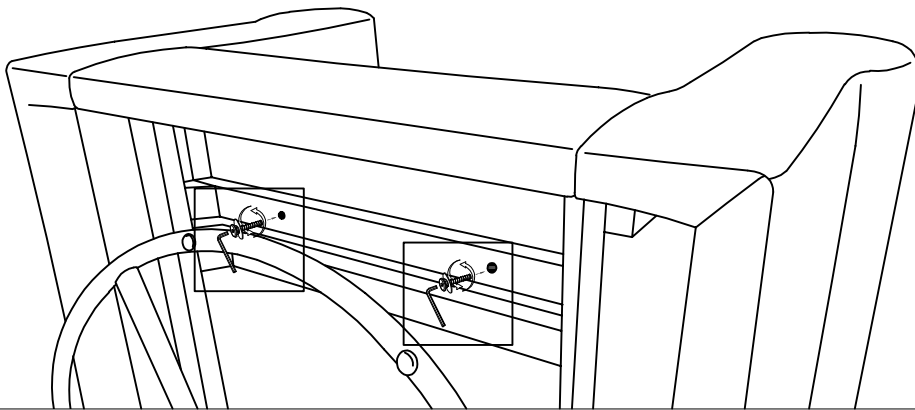

Completed

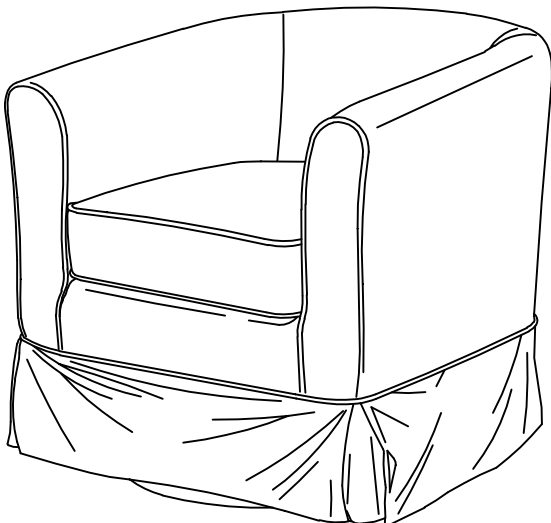

FOR LEATHER AND P.U (Code"X")

Clean by lightly brushing and vacuuming only to remove dust and particles buildup. Water-based foam cleaner or solvent based cleaning agents of any kind may cause excessive shrinking, staining or distortion of the surface pile and, therefore, should not be used.

FOR FABRIC (Code"WW")

- Use water-based agents only.
- Do not use solvents.
- Gently remove stains by blotting or hang washing.
- Do not use excessive brushing or rubbing.