

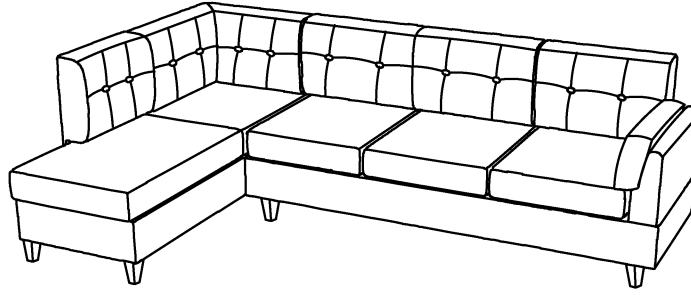









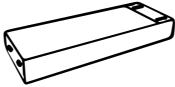

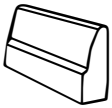

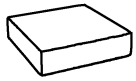

# ASSEMBLY INSTRUCTION

ITEM: 83101/83103/83105

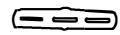

## PARTS LIST BOX-1

## PARTS LIST BOX-2

<b>A</b>	3-SEATER SEAT		x1	<b>B</b>	CHAISE SEAT		x1
<b>C</b>	ARM		x1	<b>G</b>	CHAISE BACK REST		x2
<b>D</b>	BACK REST		x3	<b>H</b>	CHAISE BACK REST		x1
<b>E</b>	BACK CUSHION		x3	<b>I</b>	CHAISE BACK CUSHION		x1
<b>F</b>	SEAT CUSHION		x3	<b>J</b>	MIDDLE BACK CUSHION		x1
<b>M</b>	WOOD LEGS		x4	<b>K</b>	FRONT BACK CUSHION		x1
<b>O</b>	METAL SUPPORT		x2	<b>L</b>	BACK SEAT CUSHION		x1
<b>X</b>	ARM CUSHION		x1	<b>N</b>	FRONT SEAT CUSHION		x1
				<b>M</b>	WOOD LEGS		x4

Open up Velcro of Non-Woven Fabric cover on the bottom of the frame to remove HARDWARE and legs . Please allow at least 24 hours for the cushions to recover to its natural state after removing from the package.

BOX-1

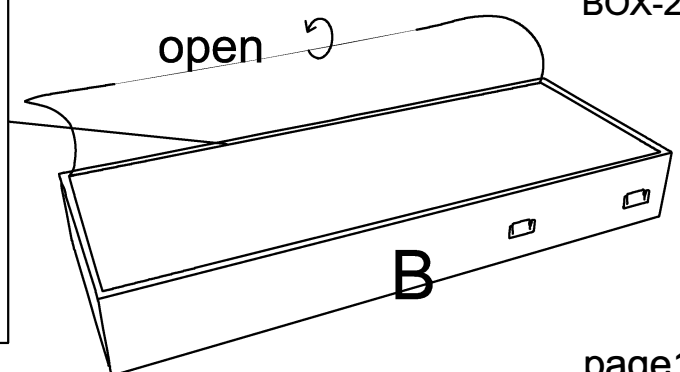
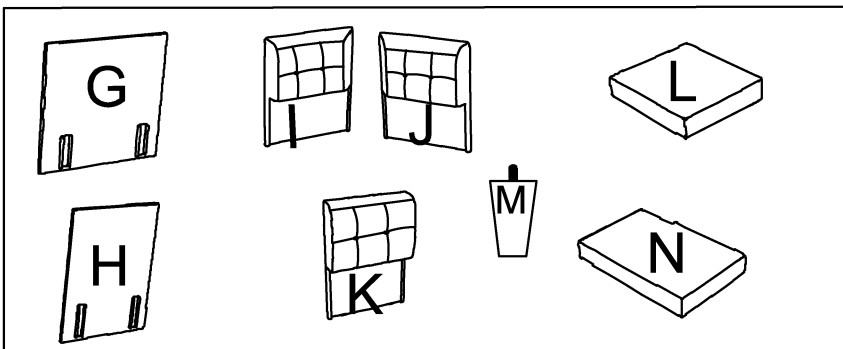
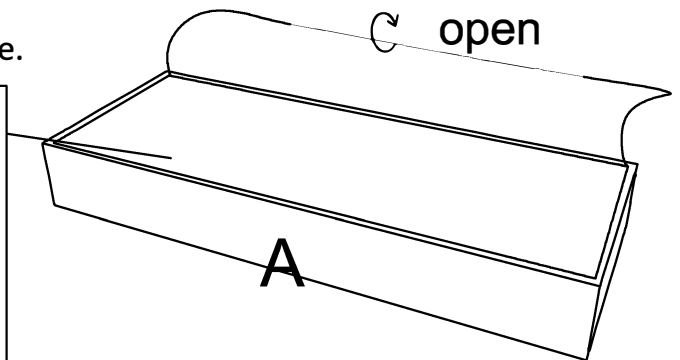
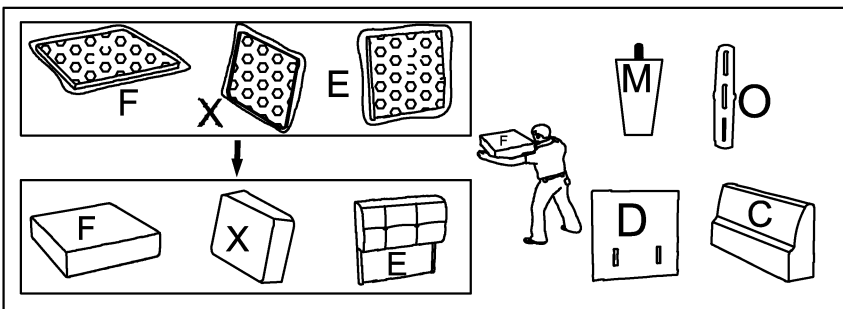

BOX-2

# ASSEMBLY INSTRUCTION

Step1

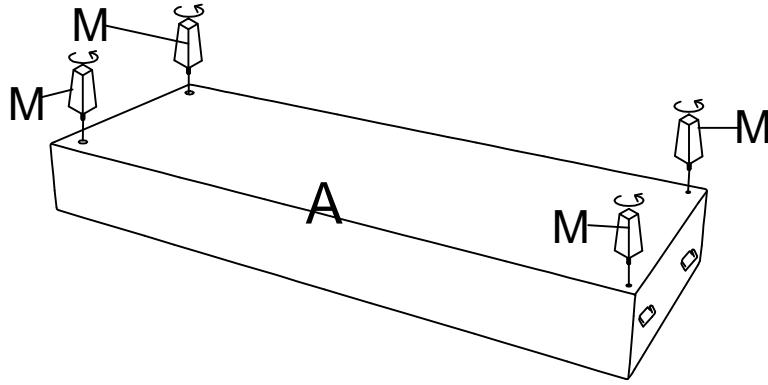

Step2

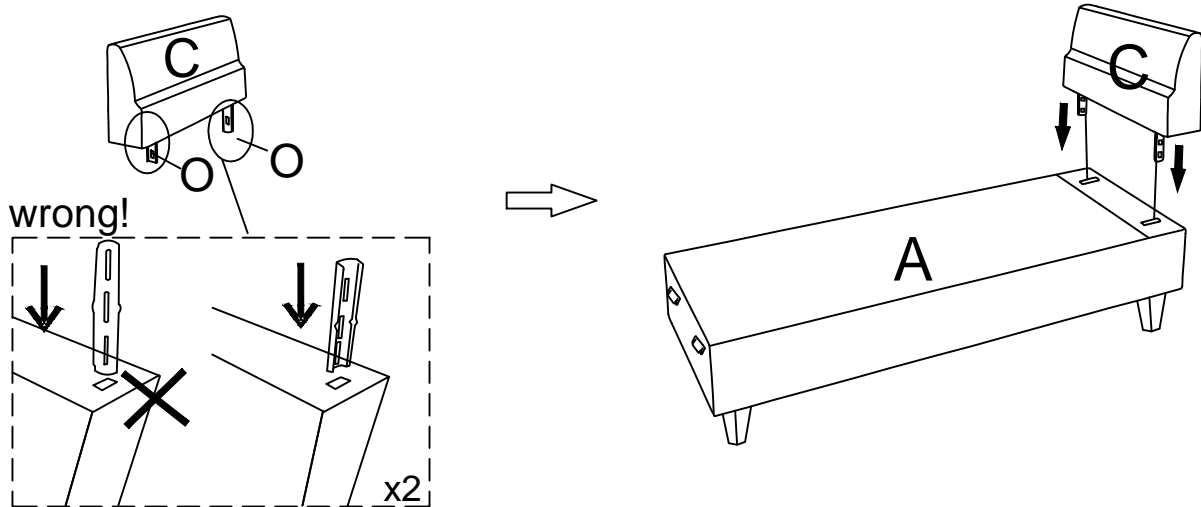

Step3

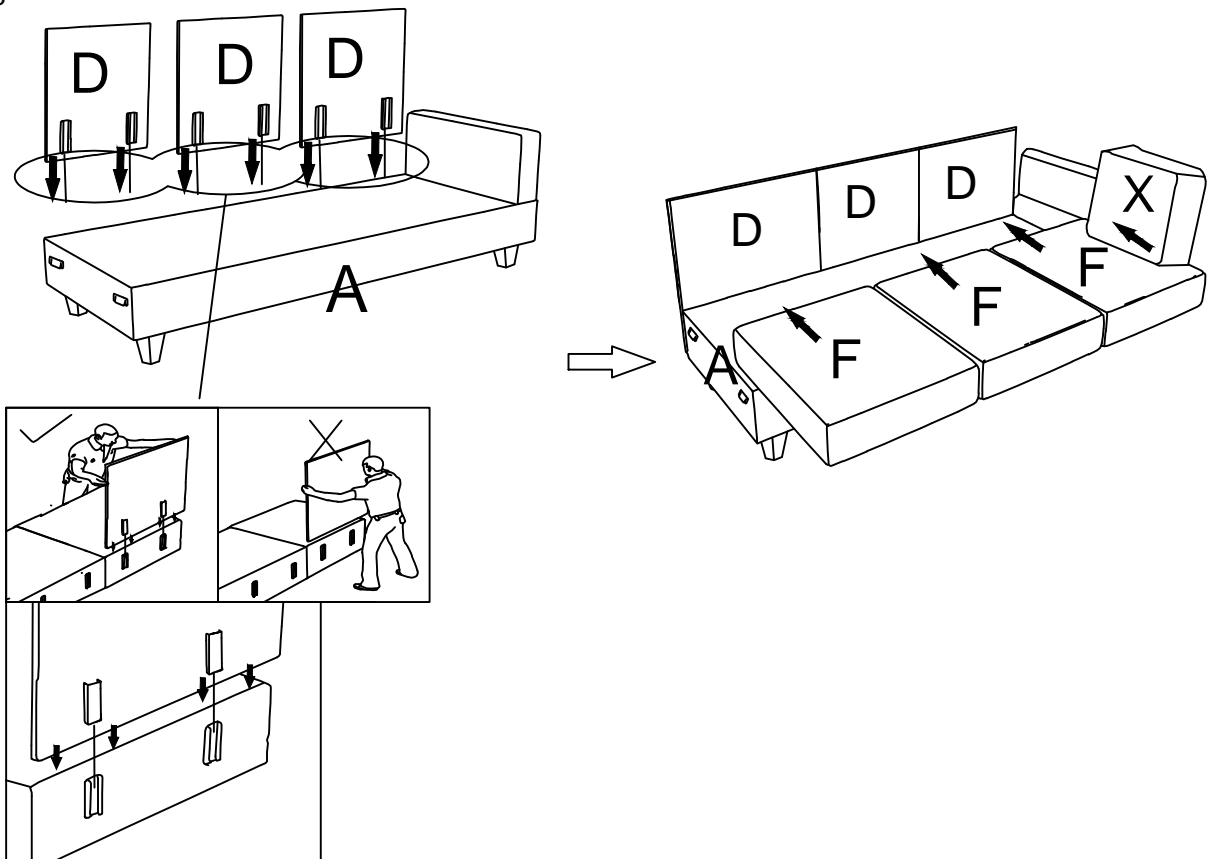

Step4

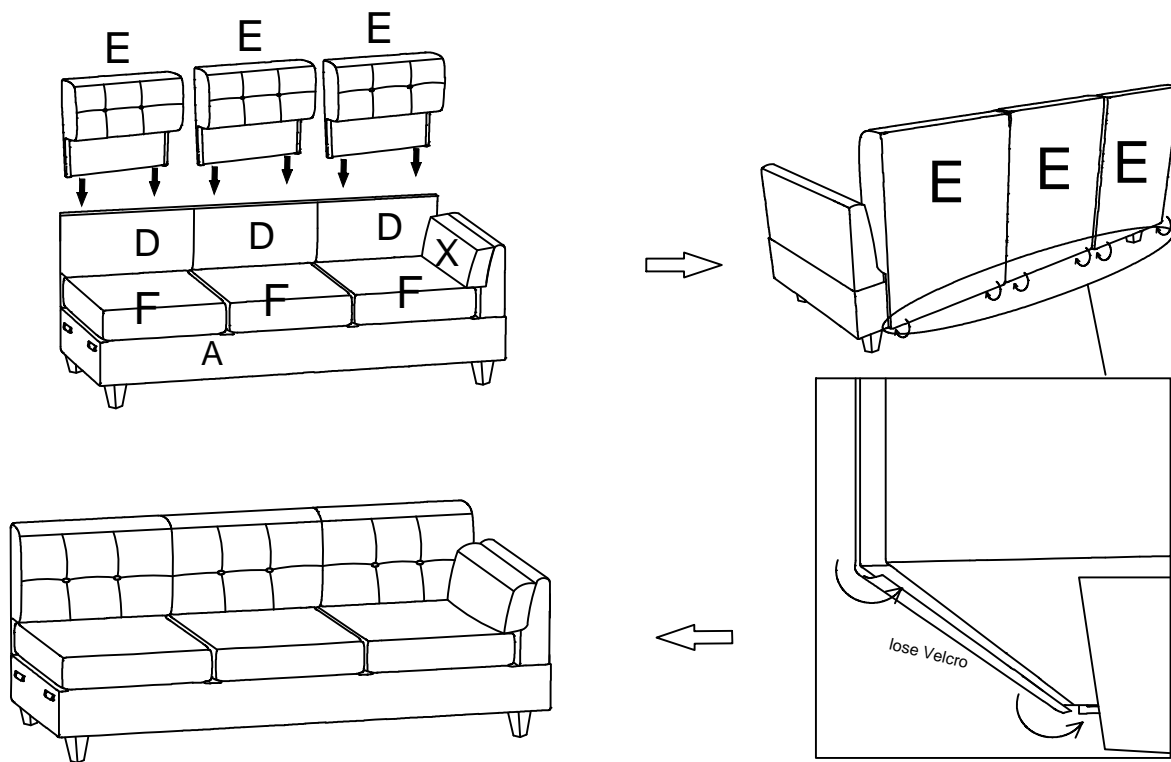

Step5

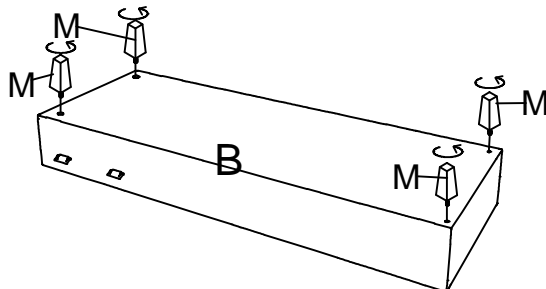

Step6

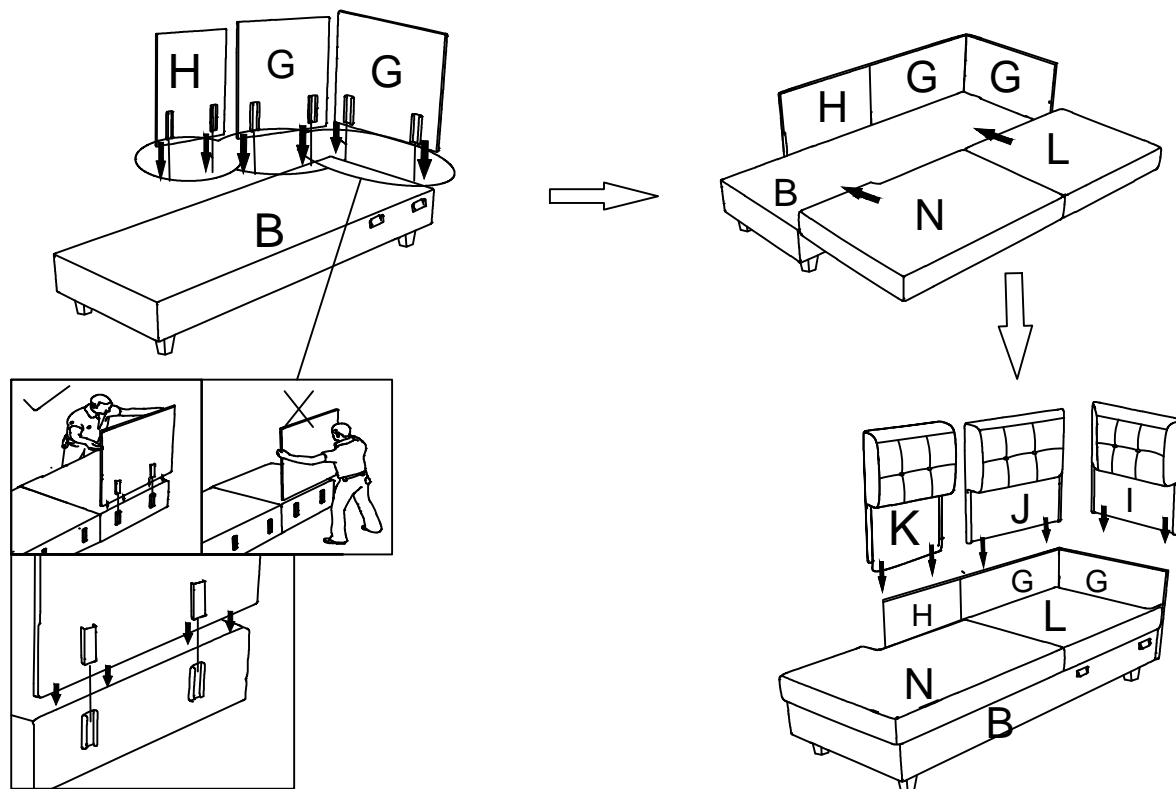

Step7

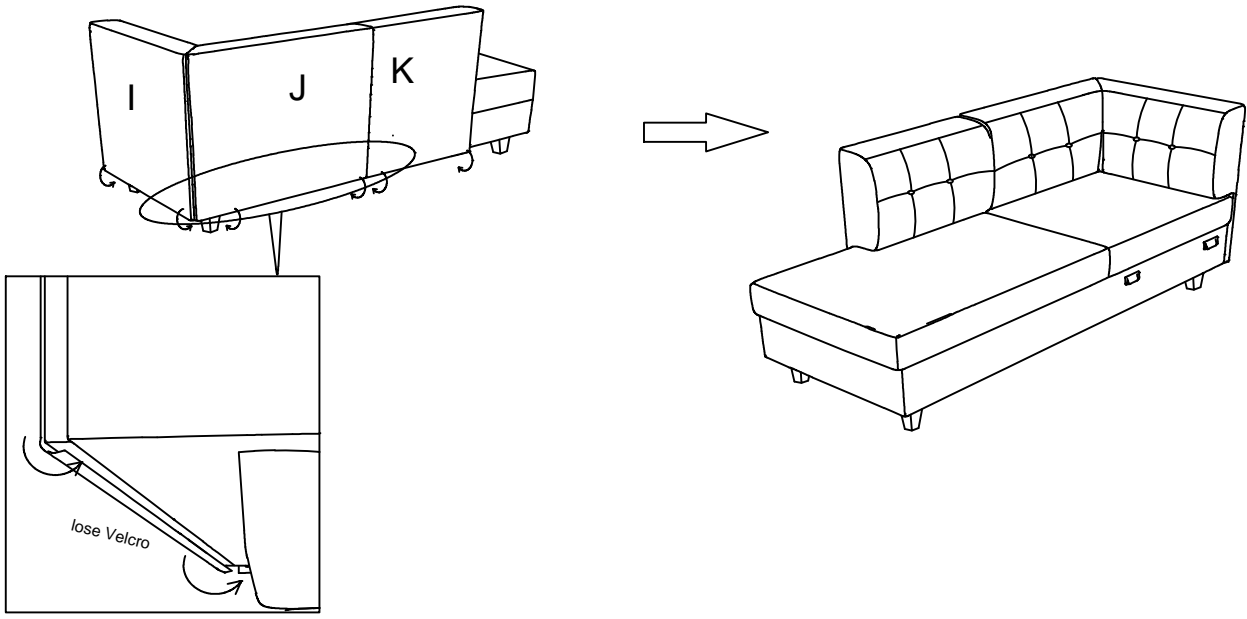

Step8

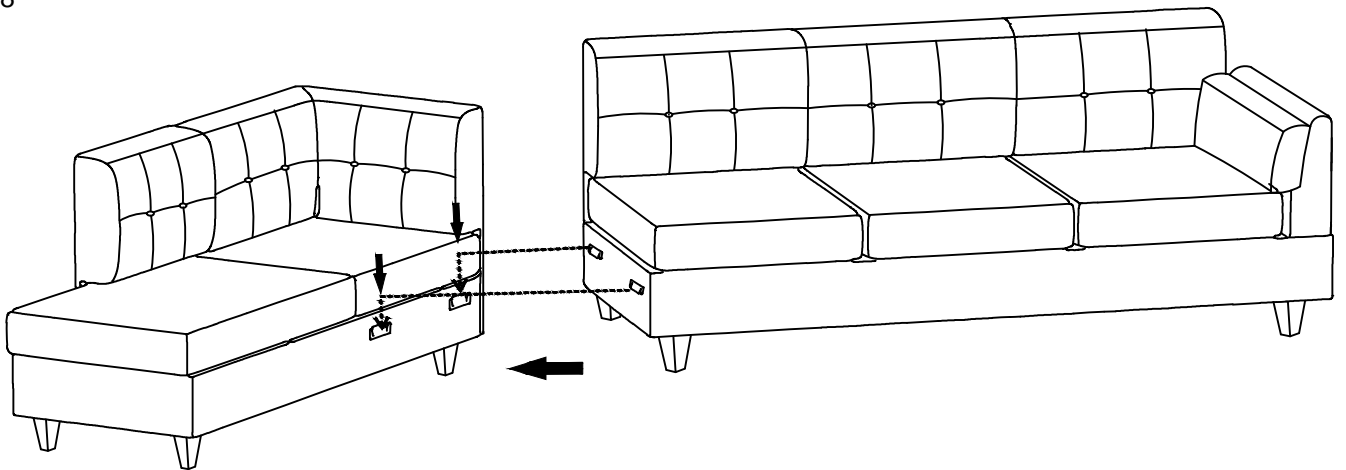

Step9

Please only choose Option1 or Option 2 to assemble  
**\*Can't reverse\***

#Option 1

#Option 2

