

ASSEMBLY INSTRUCTIONS

ITEM # 30513







Important safety instructions :

- Please read carefully all instructions before assembly.
- For your safety and ease, assembly by two or more adults is recommended.
- Keep instructions for future use.

Pre-assembly:

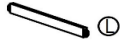

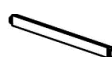

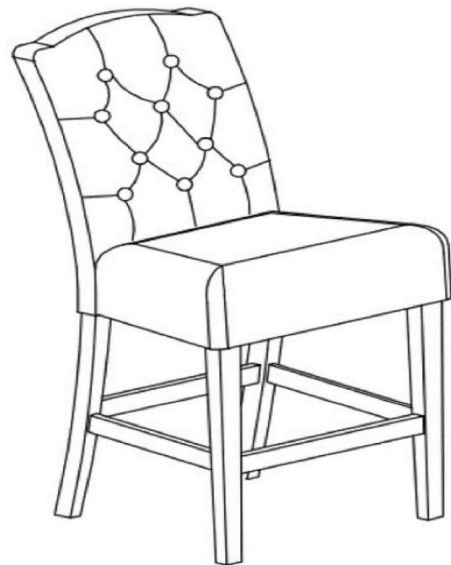

- Do not discard any contents until assembly is complete to avoid accidentally discarding small parts or hardware.
- Remove all parts and hardware from box along with any plastic protective packaging.

Parts List

| Item | Description | QTY |
|------|--|-----|
| P1 | Chair Back  | 1 |
| P2 | Seat Cushion  | 1 |
| P3 | Left Stretcher  | 1 |
| P4 | Right Stretcher  | 1 |
| P5 | Front Stretcher  | 1 |
| P6 | Front Legs  | 2 |



Hardware List

| Item | Description | QTY |
|------|---|-----------------|
| H1 | Long Bolts $\varnothing 5/16"$ x 3-1/2"  | 4 |
| H2 | Short Bolts $\varnothing 5/16"$ x 2"  | 7 |
| H3 | Lock Washers 5/16"  | 11 |
| H4 | Flat Washers 5/16"  | 11 |
| H5 | Allen Wrench 5/16"  | 1 |
| H6 | Screw #8 X 1-3/4"  | 6 |
| H7 | Screwdriver  | ** Not Provided |

DISCLAIMER :

**WHEN PROPERLY ASSEMBLED, THIS ITEM IS SAFE FOR INTENDED USE.
SELLER IS NOT LIABLE FOR ANY DAMAGES RESULTING FROM ITEM BEING IMPROPERLY ASSEMBLED
AFTER PURCHASE.**

Assembly Procedures:

Step 1.

- 1) Assemble the stool on a flat, soft surface such as carpet or cloth to prevent scratching the finish.
 - 2) Attach the Seat Cushion (P2) to Chair Back (P1) using Allen Wrench (H5), Short Bolts (H2), Lock Washer (H3), and Flat Washers (H4).
- Do not fully tighten at this step .

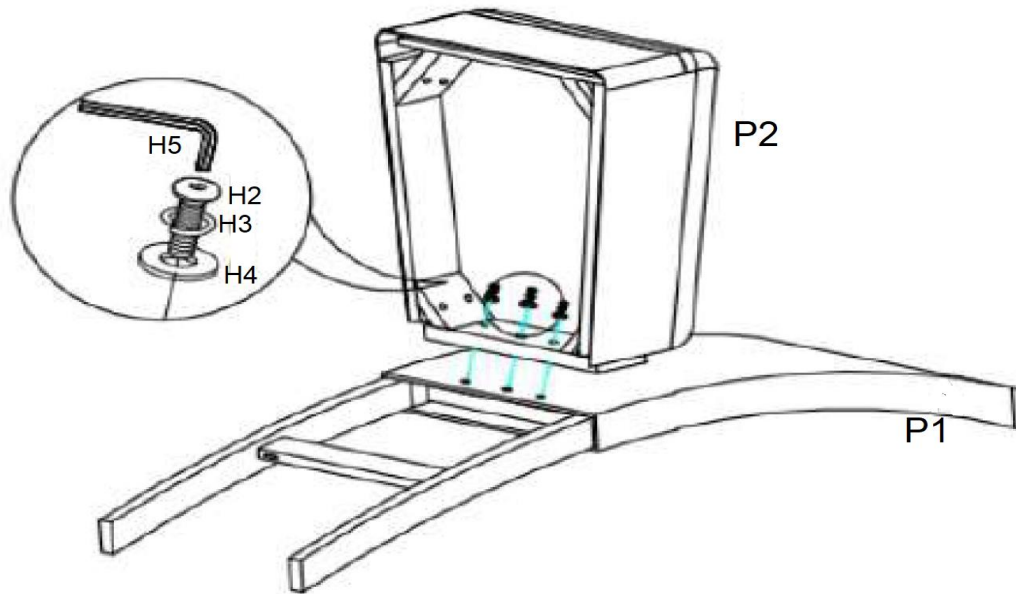

Step 2 .

- Secure the corner blocks of Seat Cushion (P2) to the legs of Chair Back (P1) with Allen Wrench (H5), Long Bolts (H1), Lock Washers (H3) and Flat Washers (H4).
- Do not fully tighten at this step .

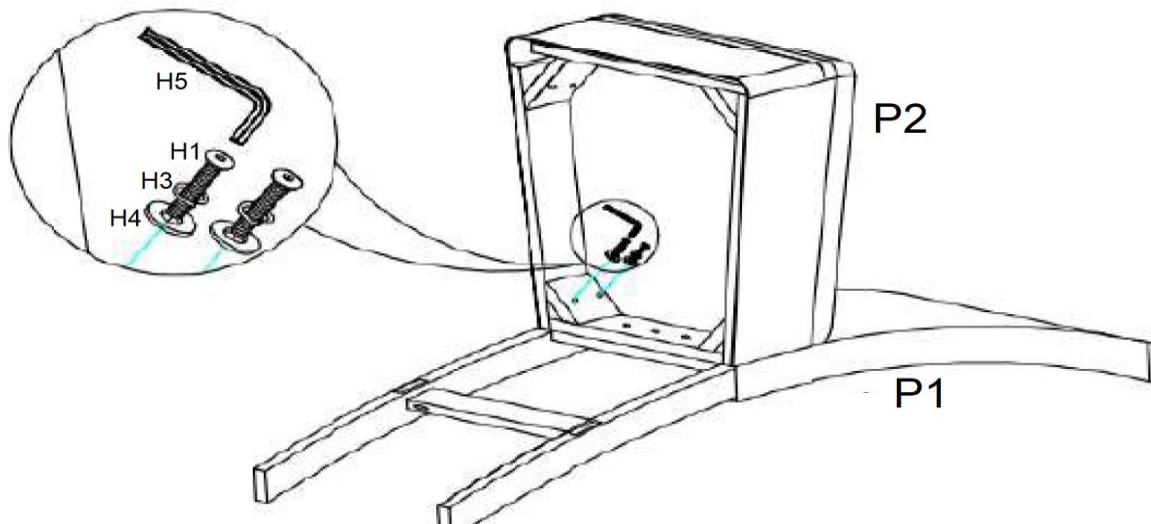

Step 3:

Attach the Right Stretcher (P4) to the right leg of Chair Back (P1) according to the label "R" at the pre-drilled hole of the right leg of Chair Back (P1) and the front end of Stretcher (P4).

2) Loosely attach one the Front Leg to the right-side bottom of Seat Cushion (P2) and Stretcher (P4) using Allen Wrench (H5), Short Bolts (H2), Lock Washers (H3) and Flat Washers (H4) .

Do not fully tighten at this step .

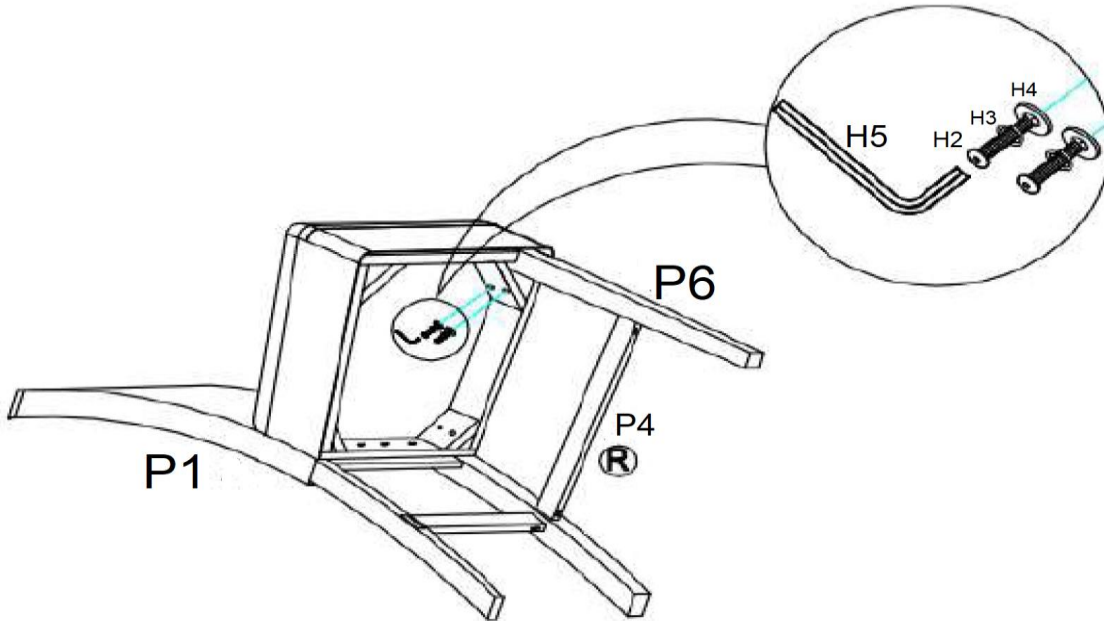

Step 4 :

1) Attach the Left Stretcher (P3) to the left leg of Chair Back (P1) according to the label "L" at the pre-drilled hole of the left Leg of Chair Back (P1) and the front end of Left Stretcher (P3) .

2) Loosely attach another Front Leg (P6) to the left-side bottom of Seat Cushion (P2) and Left Stretcher (P3) using Allen Wrench (H5), Short Bolts (H2), Lock Washers (H3) and Flat Washers (H4) .

3) Attach the Front Stretcher (P5) between the Front Legs (P6) .

4) Fully tighten all Bolts (H1 , H2) .

5) Secure and fully tighten with screwdriver for all Screws (H6) at the Stretcher (P3 ,P4,P5).

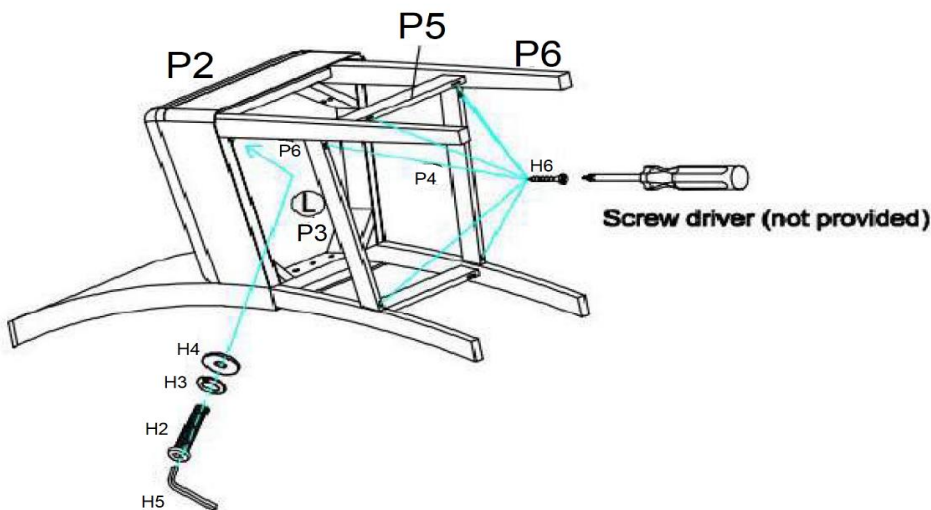

ADDITIONAL NOTE ABOUT SAFETY : BOLTS MAY LOOSEN DURING NORMAL EVERYDAY USE. THEY SHOULD BE PERIODICALLY INSPECTED AND RE-TIGHTENED TO PREVENT DAMAGE OR INJURY. ALWAYS CHECK TO ENSURE THAT ALL HARDWARE IS KEPT TIGHTENED .

THANK YOU FOR YOUR PURCHASE