









# Assembly Instruction for BAR TABLE SINGLE PACK (TABLE + 2 STOOLS) 30010&30011

**Caution:** Please read instructions thoroughly before unpacking assembly parts. Sharp, exposed staple tips can cause injury. therefore, for your protection, please remove any exposed staples used in packing.

1. We recommend that you should assemble this product with the assistance of another person; this will make assembly easier and will help to eliminate damage to the product or injury to persons during assembly.
2. Be sure to check all packing materials carefully for small parts that may have come loose inside the carton during shipment.
3. To avoid damage, assemble on soft surface such as carpet or cloth. Follow steps below to assemble product correctly and efficiently.
4. Please do not over tighten screws or bolts. Do not use power tools. Periodically check all hardware and re-tighten as necessary.

PART LIST		
NO.	PART DESC.	Q'TY
A	STOOL SEAT	2
B	STOOL LEG	8
C	LONG STRETCHER	4
D	SHORT STRETCHER	4
E	TABLE TOP	1
F	TABLE LEG	4

HARDWARE LIST			
NO.		HARDWARE DESC	Q'TY
①		ALLEN BOLT (Ø1/4"x 50mm)	16
②		SPRING WASHER(Ø1/4")	16
③		FLAT WASHER (Ø1/4"x 19mm)	16
④		SCREW (50mm)	16
⑤		ALLEN KEY (M4)	2
⑥		ALLEN BOLT (Ø5/16" x 65mm)	8
⑦		SPRING WASHER (Ø5/16")	8
⑧		FLAT WASHER (Ø5/16"x 22mm)	8
⑨		ALLEN KEY (M5)	1

**STEP : 1** Insert Stretchers (C & D) between Stool Legs (B), noting correct orientation of screw holes. Secure Stool Legs (B) to Stool Seat (A) first. Then secure all end of Stretchers (C & D) to Stool Legs (B) last.

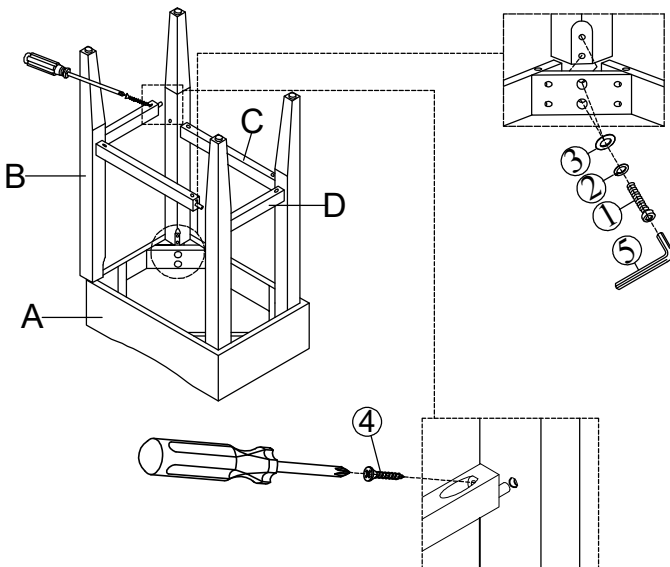

Ensure screw holes in stretchers face as shown on diagram. If stretchers are properly oriented, once stool is turned upright, screw holes will face toward floor.

**STEP : 2**

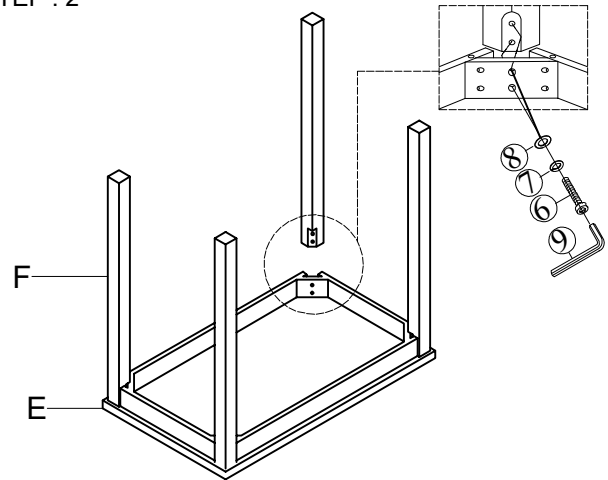

**COMPLETED**

