







ASSEMBLY INSTRUCTIONS

COLTON ENDTABLE L500x W500 x H500 mm

No.	Hardware List		Q'ty
1		Connecting set	4
2			
3		Bolt 8x40	16
4		Flat Washer	16
5		Lock Washer	16
6		Allen wrench 4mm	1
7		Allen wrench 5mm	1

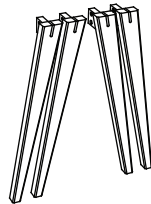
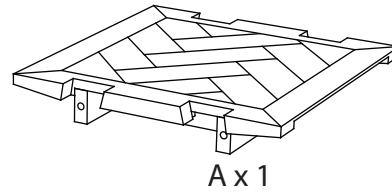

Step 1

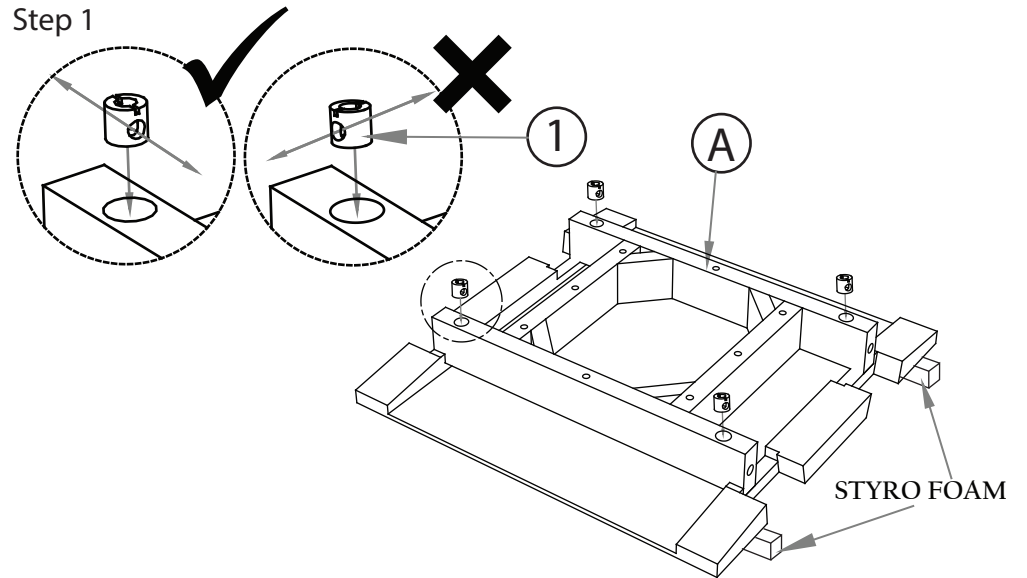

Step 2

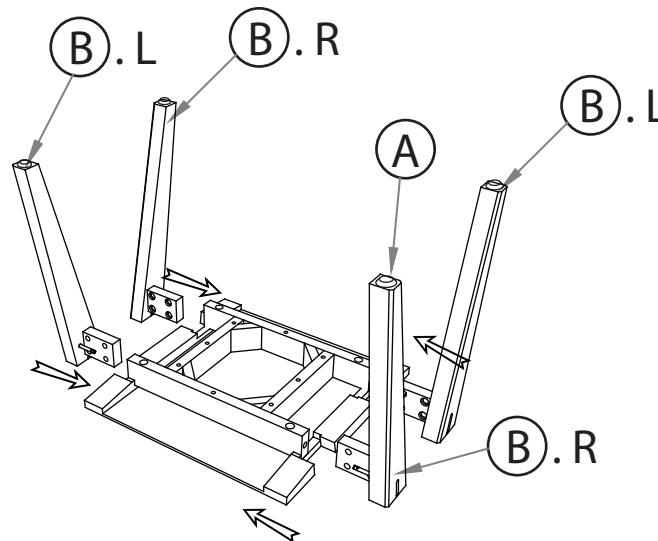

Step 3

REMARK:

- When attaching the table top, put all bolts, screws lightly in place.
- Checking cross distance top and bottom of legs and then tightening all bolts and screws .

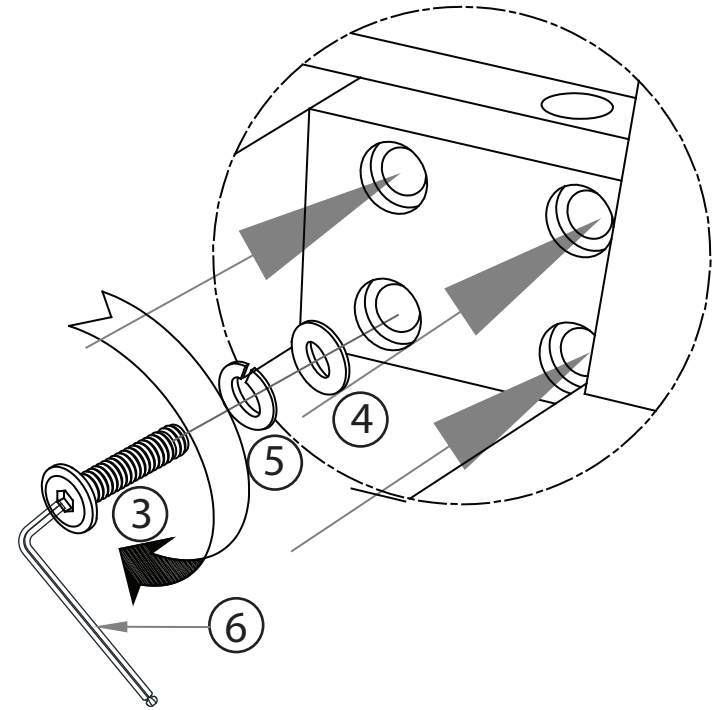
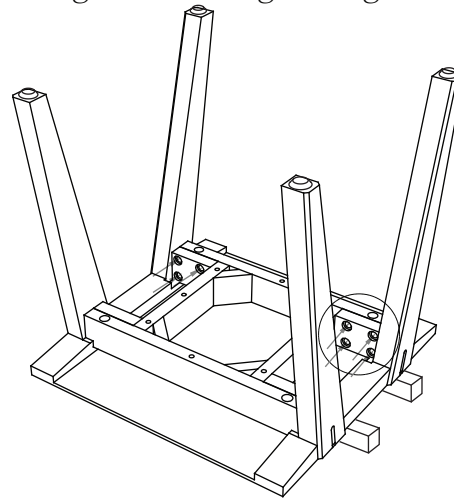

Step 4

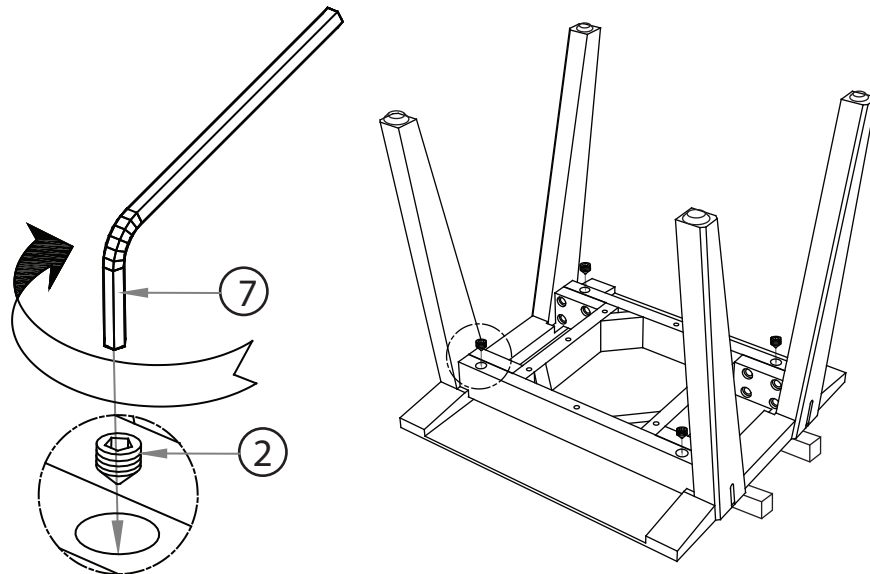

Finished!

