

ASSEMBLY INSTRUCTIONS:

2800-4104-PANEL HEADBOARD FULL 46
 2800-4114-PANEL FOOTBOARD FULL 46
 2800-4900-RAILS TWIN 33 FULL 46

Thank you for purchasing this quality product. Before beginning, please check the packing material carefully for small parts which may have come loose inside the carton during shipping. Please do not discard any packing material until all parts have been located. If any parts are missing, please contact your dealer for prompt replacement.

Caution: (1) These parts are cumbersome and heavy. This product can best be assembled with the assistance of one or more persons in order to prevent personal injury and to insure parts are not damaged during the assembly process. If dirty, clean finished parts with mild dishwashing liquid and water solution applied on damp cloth. Cloth should not be excessively wet. Polish finish with soft cloth and an industry recognized furniture polish.

(2) To prevent damage to your floor or carpet, please check the bottom of each piece of furniture for stain residue and rough surfaces and also check for staples or nails left after removing the packaging material. The manufacturer will not be held responsible if preventative steps are not taken prior to installation.

(3) During normal use everyday, screws, bolts, nuts and wooden plugs may loosen up. They should be periodically inspected and re-tightened to prevent damage to the furniture and (or) personal property or cause injury. Always check to be sure all hardware on this list and the below mentioned components are attached to the furniture properly and kept tightened.

Parts & Hardware List:

PARTS LIST		QTY	PARTS LIST		QTY	HARDWARE LIST		QTY	HARDWARE LIST		QTY
A	HEADBOARD	1pc	D	FOOTBOARD	1pc	1	BOLT Ø1/4"*1-3/8"	12pcs	6	LONG BOLT Ø5/16" x 2-3/4"	8pcs
B	RIGHT POST	1pc	E	RAIL	2pcs	2	LOCK WASHER 1/4"*2/5"	12pcs	7	FLAT WASHER 5/16"*3/4"	8pcs
C	LEFT POST	1pc	F	SLAT	1Set	3	FLAT WASHER 1/4"*3/4"	12pcs	8	LOCK WASHER 5/16"*1/2"	8pcs
						4	ALLEN 1/6"*2-1/3"	1pc	9	NUT Ø5/16"-3/8"	8pcs
						5	WOOD SCREW #8*1-3/16"	10pcs	10	OPEN WRENCH 1/2"	1pc

Step 2

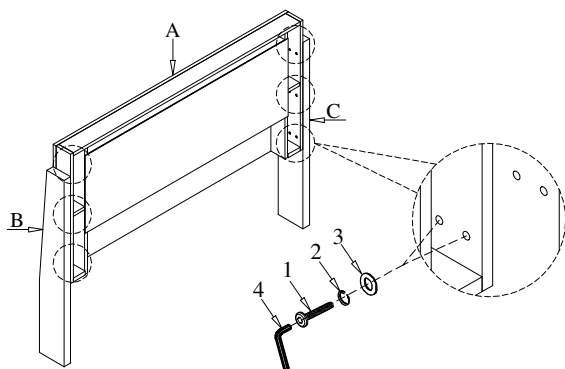

Step 3

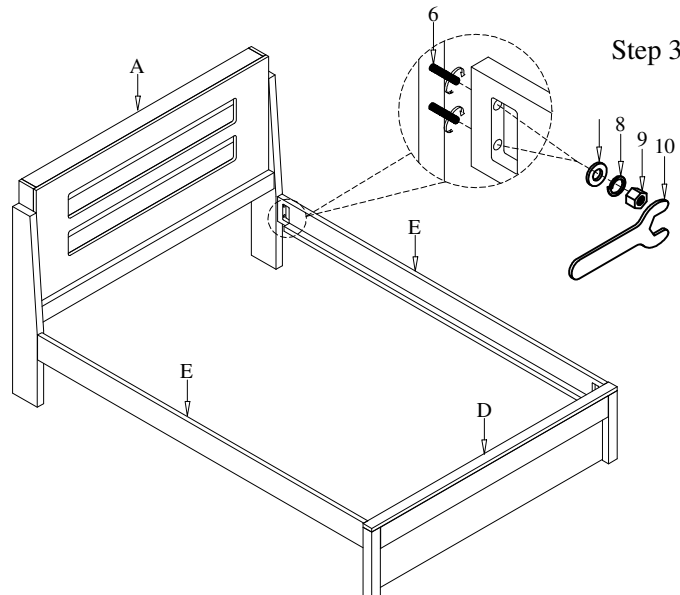

Assembly Procedures :

Step 1: Lay out all parts and hardware on a clean protective surface to protect the furniture and floor during assembly. Make sure the quantity of each is correct and the feet are free of stain, staples, screws and nails.

Step 2: Assemble the right post (B) and left post (C) to headboard (A) using hardware (1,2,3,4) as shown.

Step 3: Assemble the bed rails (E) to the headboard (A) and footboard (D) using hardware (7,8,9,10) as shown.

ASSEMBLY INSTRUCTIONS:

LEGACY

CLASSIC | MODERN

2800-4104-PANEL HEADBOARD FULL 46
2800-4114-PANEL FOOTBOARD FULL 46
2800-4900-RAILS TWIN 33 FULL 46

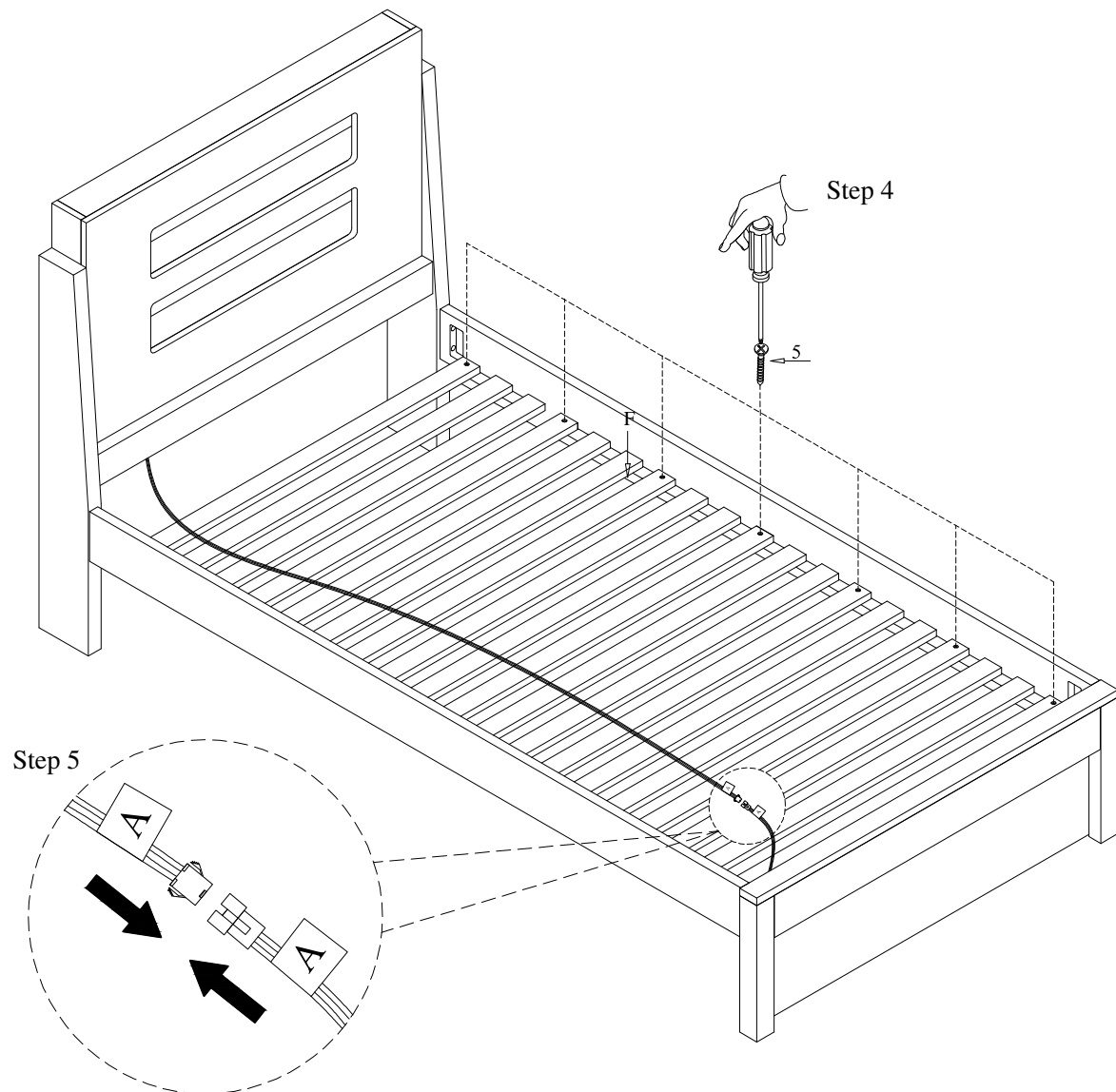

Assembly Procedures :

Step 4: Place the slat roll (F) on the bed rails and fasten with wood screws (5) as shown.

Step 5: Connect the wire for the led light of the headboard to the footboard as shown.

FULL BED

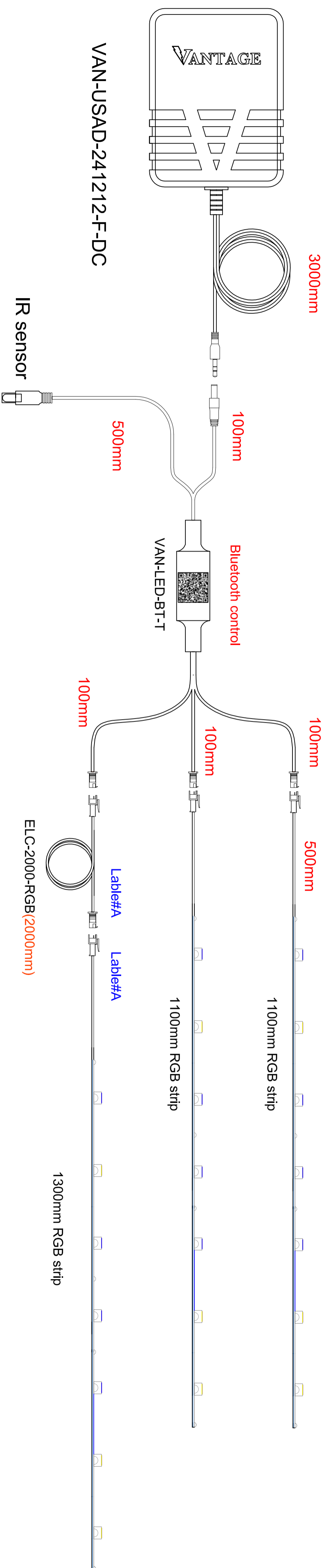

Scan QR code to download
APP to control lights



VAN-USAD-2412-F-DC	1	
VAN-5050RGB30D-10MM-12V-11S	2	
VAN-5050RGB30D-10MM-12V-13S	1	
VAN-LED-BT-T	1	