

# ASSEMBLY INSTRUCTIONS :

1500-4106/4116/4901 PANEL BED KING 6/6

# LEGACY

CLASSIC | MODERN



















Thank you for purchasing this quality product. Before beginning, please check the packing material carefully for small parts which many have come loose inside the carton during shipping. Please do not discard any packing material until all parts have been located. If any part are missing, please contact your dealer for prompt replacement.

**Caution:** (1) These parts are cumbersome and heavy. This product can best be assembled with the assistance of one or more persons in order to prevent personal injury and to insure part are not damaged during the assembly process. If dirty, clean finished parts with mild dishwashing liquid and water solution applied on damp cloth. Cloth should not be excessively wet. Polish finish with soft cloth and an industry recognized furniture polish.

(2) To prevent damage to your floor or carpet, please check the bottom of each piece of furniture for stain residue and rough surfaces and also check for staples or nail left after removing the packaging material. The manufacturer will not be held responsible if preventative steps are not taken prior to installation.

(3) During normal use everyday, screws, bolts, nuts and wooden plugs may loosen up. They should periodically inspected and re-tightened to prevent damaged to the furniture and (or) personal property or cause injury. Always check to be sure all the hardware on this list and the below mentioned component are attached to the furniture properly and kept tightened.

## Parts & Hardware List:

PARTS LIST			QTY	PARTS LIST			QTY	HARDWARE LIST			QTY	HARDWARE LIST			QTY
A	HEADBOARD PANEL		1 PC	E	BED RAIL		2 PCS	1	BOLT		8 PCS	7	ALLEN LONG BOLT		8 PCS
B	HEADBOARD LEG		2 PCS	F	METAL LEG		2 PCS	2	NUT		8 PCS	8	ALLEN SHORT BOLT		10 PCS
C	HEADBOARD STRETCHER		1 PC	G	SLAT RAIL		3 PCS	3	WRENCH		1 PC	9	LOCK WASHER		18 PCS
D	FOOTBOARD		1 PC	H	SUPPORT LEG		6 PCS	4	LOCK WASHER		8 PCS	10	FLAT WASHER		18 PCS
								5	CURVED WASHER		8 PCS	11	ALLEN WRENCH		1 PC
								6	SCREW		6 PCS				

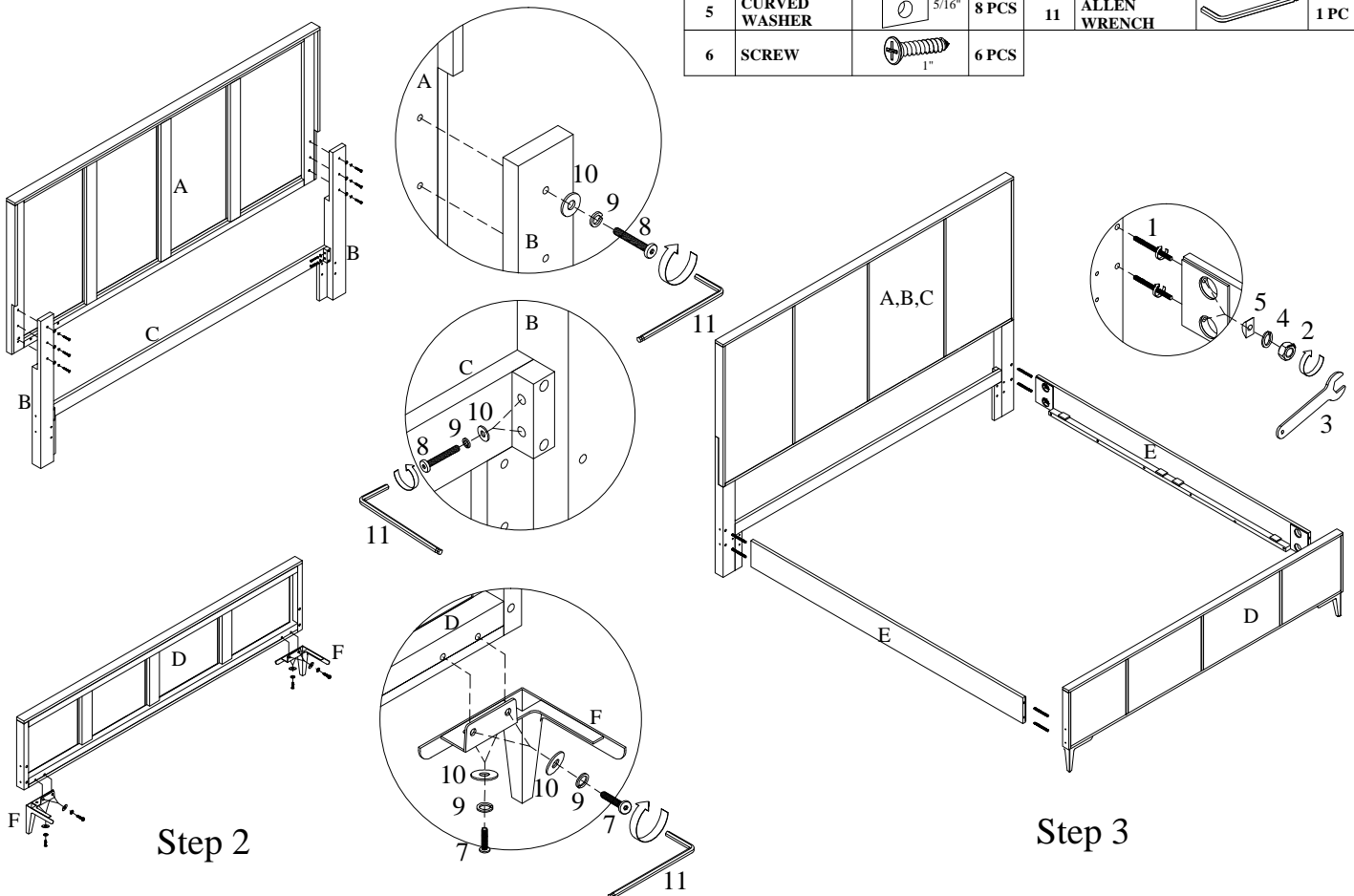

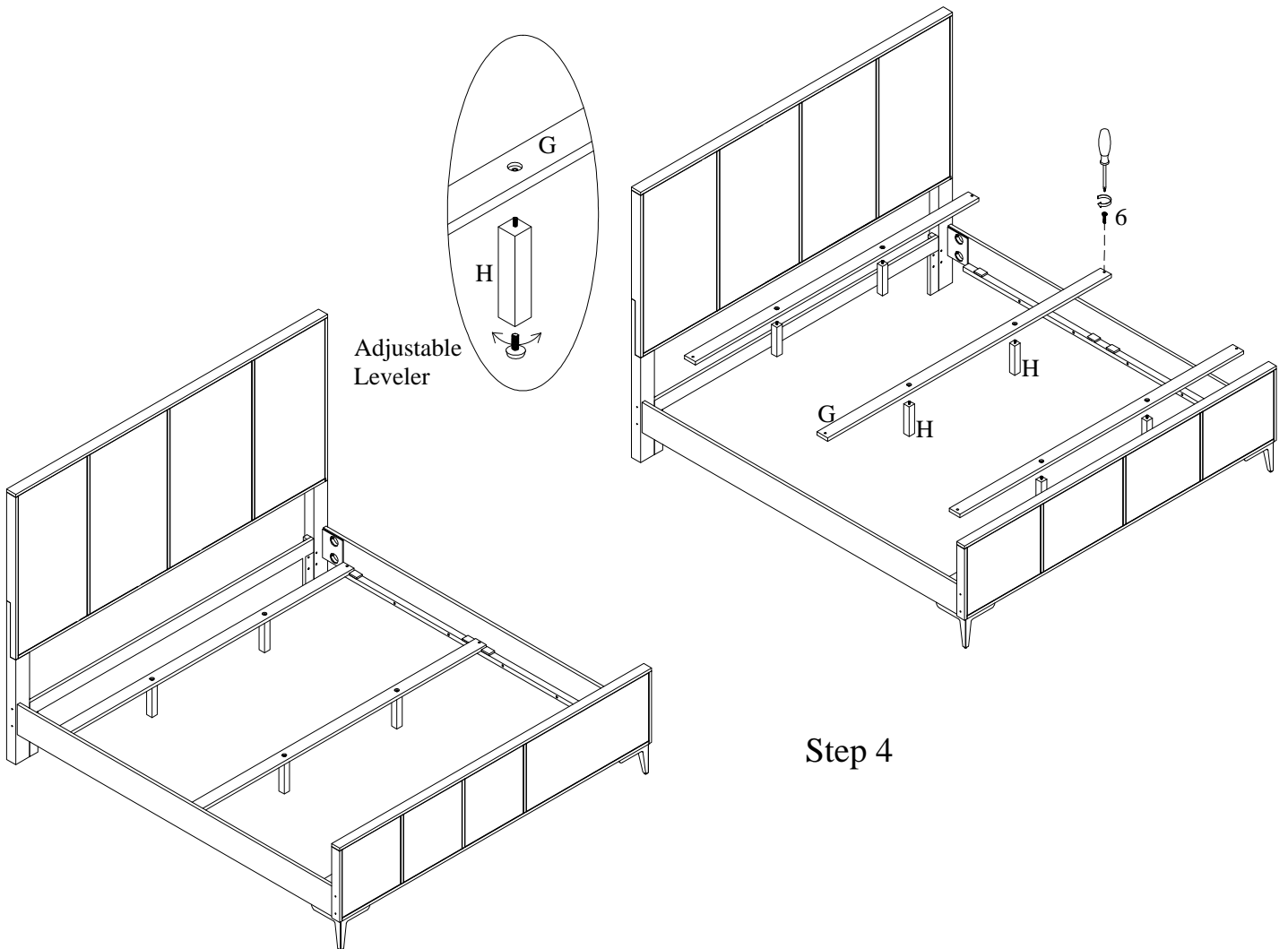

### **Assembly Procedures:**

- Step 1: Lay out all parts and hardware on a clean protective surface to protect the furniture and floor during assembly. Make sure the quantity of each is correct and the feet are free of stain, staples, screws and nails.
- Step 2: Assemble the Headboard Panel (A), Headboard Leg (B) and Headboard Stratcher (C) using hardware (8,9,10,11) as shown. Also assemble the Footboard (D) and Leg (F) using hardware (7,9,10,11) as shown.
- Step 3: Assemble the Bed Rails (E) to the Headboard (A,B,C) and the Footboard (D,F) using hardware (1,2,3,4,5) as shown.
- Step 4: Assemble the Support Leg (H) to the Slat Rails (G), then put the Slat Rails (G) on the bed rails and fasten wood screws (6) as shown. The support leg leveler need to touch the floor to support the slat rails and the mattress.  
Assembly is complete.